

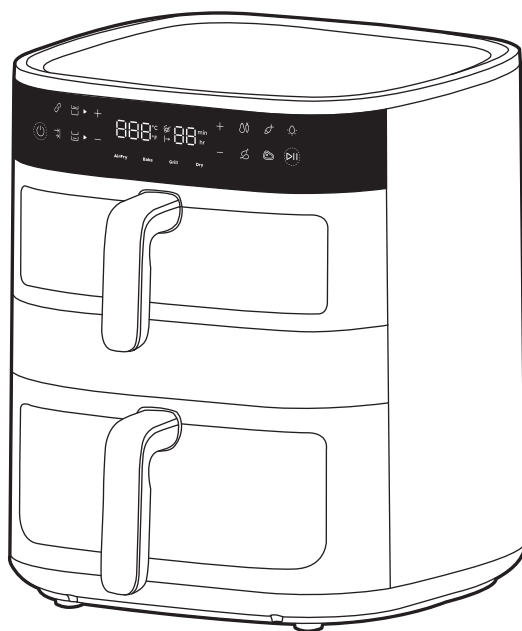

Instruction Book



800 Air Fryer Dual

General Overview

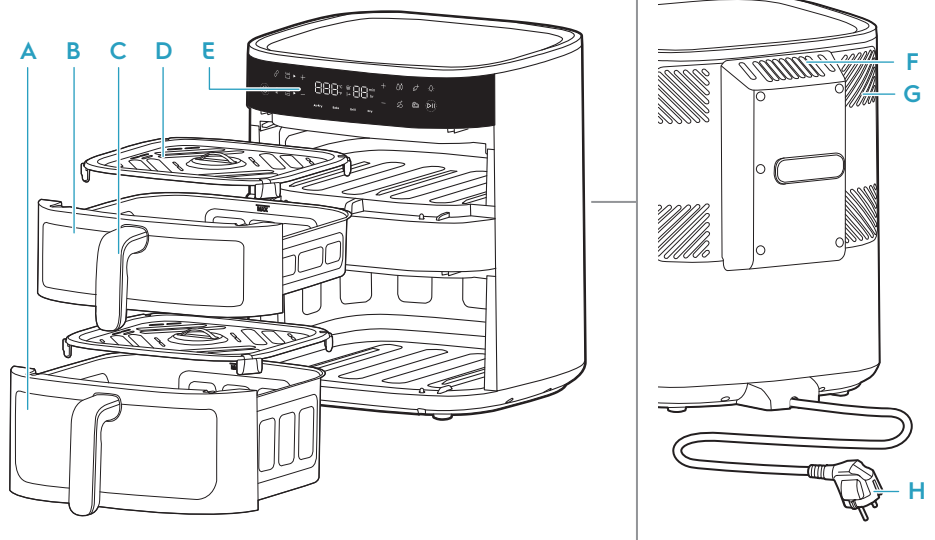

- | | | | |
|-----------------------------|------------------------|------------------------|-------------------------|
| A Bottom basket (7L) | C Basket handle | E Control panel | G Cooling system |
| B Top basket (4L) | D Grid | F Air outlet | H Main cord |

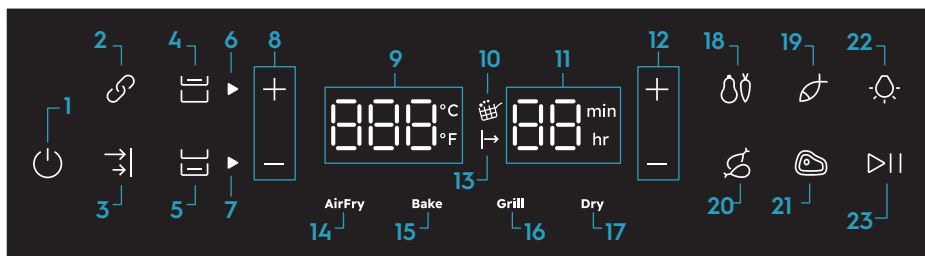

- | | | | |
|----------------------------|---|------------------------|-------------------|
| 1. On/Off | 8. Temperature control | 12. Time control | 18. Vegetables |
| 2. Link function | 9. Temperature indicator (40-200°C) | 13. Waiting to cooking | 19. Fish |
| 3. Sync End function | 10. Shake Reminder | 14. AirFry function | 20. Chicken |
| 4. Top basket control | 11. Time indicator (AirFry: 1-99min, Dehydrate: 1-5h) | 15. Bake function | 21. Steak |
| 5. Bottom basket control | | 16. Grill function | 22. Light control |
| 6. Top basket indicator | | 17. Dry function | 23. Play/Pause |
| 7. Bottom basket indicator | | | |

Before first use

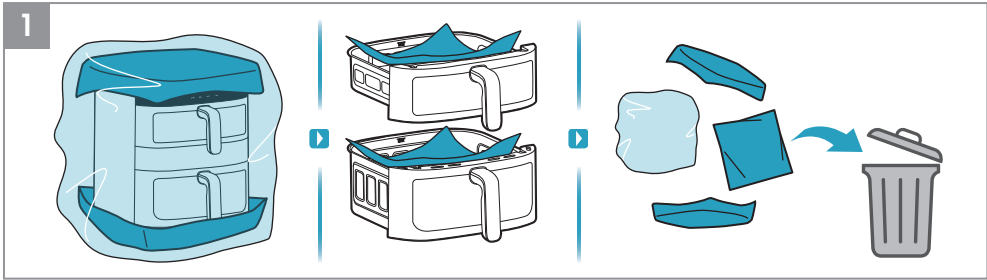

1. Remove all the packaging and protective material.

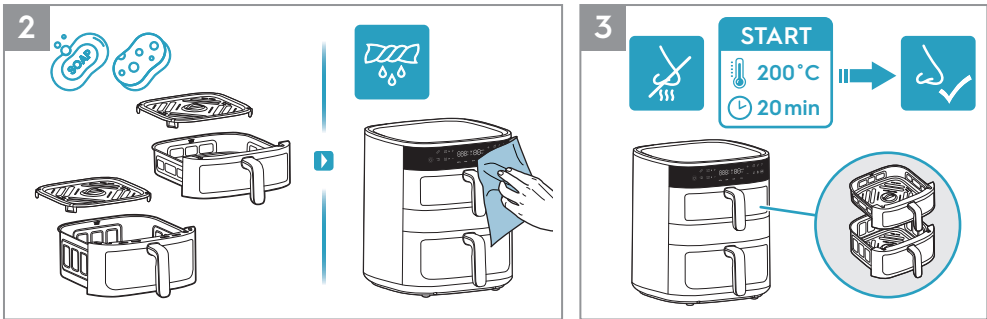

2. Clean the pan and grid with warm water and dish soap. Wipe inside and outside of the appliance with a soft cloth.
3. It is normal for a new unit to emit odors the first few times it is operated. Run the empty air fryer at 200°C for 20 minutes before first use to avoid that.

! Safety precautions

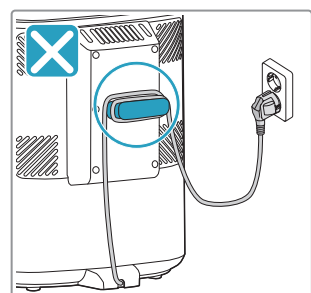
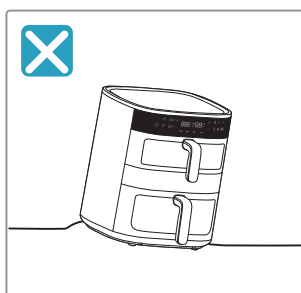
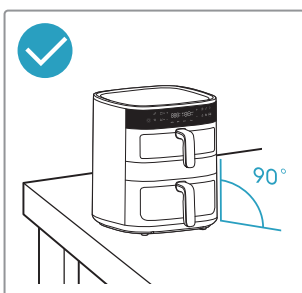
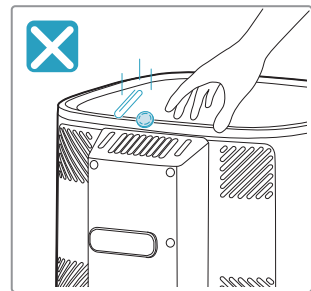
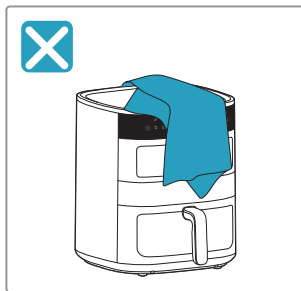

EN

BG

CZ

DE

DK

EE

FI

FR

GR

HR

HU

IT

LT

LV

NO

NL

PL

PT

RO

RU

SE

SI

SK

SR

TR



UA

ES





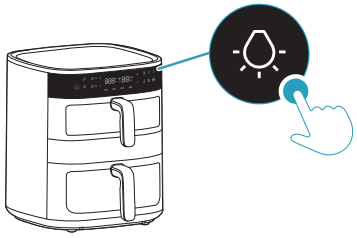
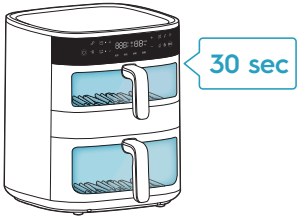

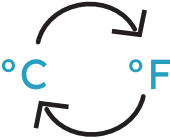



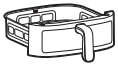

GE

AL







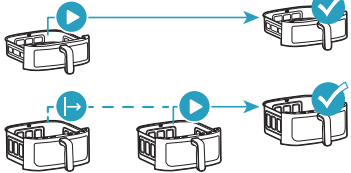







Lighting control & temperature scale conversion

 <p>Lighting control</p>		
<p>°C/°F</p> <p>Temperature scale conversion</p>		

Basket selection

	 <p>4L</p>	 <p>7L</p>	
 <p>Top Basket</p>			
 <p>Bottom Basket</p>			
 <p>Link function</p>			
 <p>Sync end function</p>			

Pre-set Functions

					
AirFry	180°C	15min	60~200°C	1~99min	
	170°C	10min	60~200°C	1~99min	
	140°C	15min	60~200°C	1~99min	
	180°C	30min	60~200°C	1~99min	
	200°C	10min	60~200°C	1~99min	
Bake	170°C	15min	60~200°C	1~99min	
Grill	200°C	5min	60~200°C	1~99min	
Dry	80°C	5h	40~80°C	1~5h	

Before Cooking

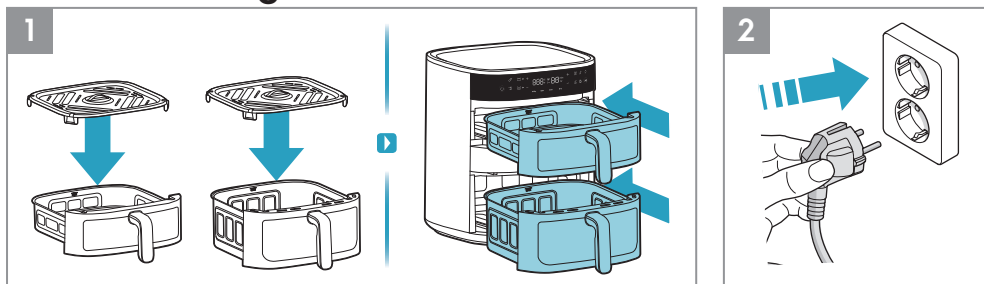

1. Before each cooking, please place the grid into the basket (the heat-resistant silicone foot pad of the grid does not need to be removed), and fully push the basket into the appliance.
2. Insert the power plug into the power outlet.

EN

BG

CZ

DE

DK

EE

FI

FR

GR

HR

HU

IT

LT

LV

NO

NL

PL

PT

RO

RU

SE

SI

SK

SR

TR

UA

ES

GE

AL

How to use - Single basket

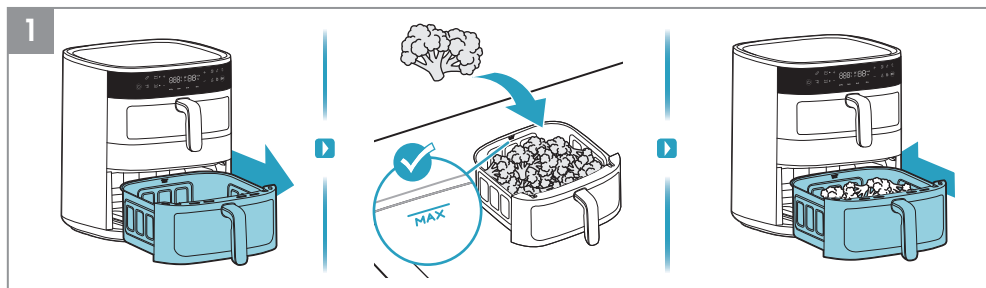

1. Pull out one basket and place it on a stable surface, put the food in the basket, observing the "MAX." capacity indication. Then push the basket with food completely back into the appliance.

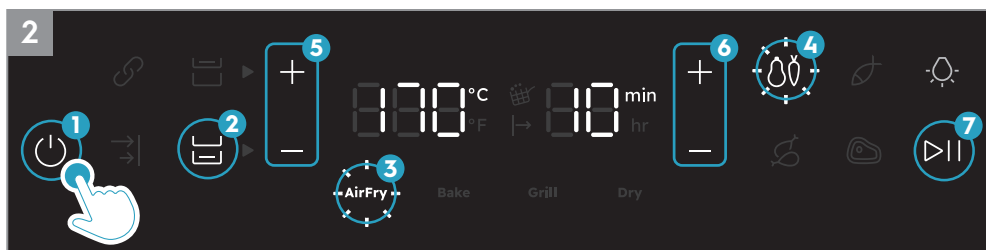

2. Press the On/Off button. First select the basket with food. Then select your desired cooking method, for example, Air Fry function. Adjust the time and temperature to your taste or select one of the pre-set recipes, for example, Vegetable. At last, press the Play/Pause button.

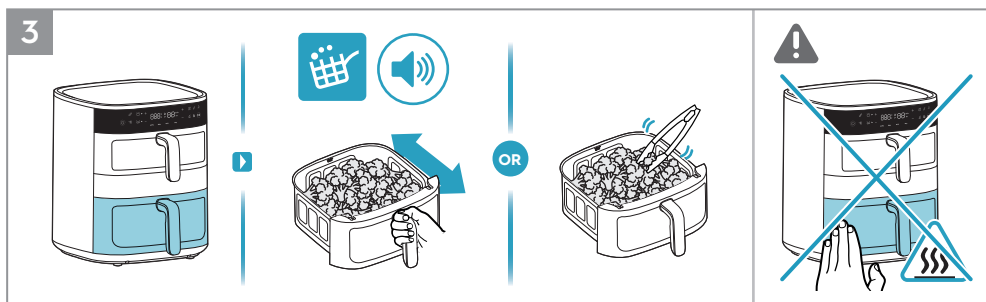

3. When the "Shake Reminder" icon lights up and beeps during the cooking process, use heat-resistant tools to flip the food once or carefully shake the food in the frying basket slightly.

⚠ **CAUTION:** Do not shake the frying basket vigorously to avoid food splashing and causing burns.

⚠ **CAUTION:** Be careful with hot surfaces when the appliance is in use.

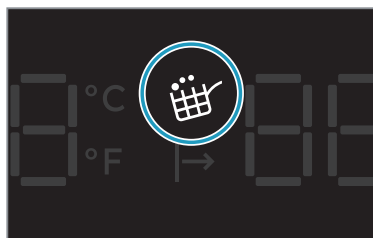

Shake Reminder

The "Shake Reminder" is activated during Air Fry function and the pre-sets recipes, such as vegetables, Fish, Chicken legs and Steak.

When it is time to shake or flip your food, the "Shake Reminder" icon will light up and blink for one minute, while a beep sound will repeat for three times.

The "Shake Reminder" is not mandatory, hence the cooking will continue as usual even if the food is not flipped or shaken.



4. At the end of the cooking time, the appliance will issue a beep signal. Carefully remove the basket and place it on a heat-resistant surface. Unplug the appliance after using it.

⚠ **CAUTION:** Hot steam can come out of the basket when it is opened mid or at the end of cooking. Make sure your face, arms and hands are away from the steam when opening it.

How to use - Top + Bottom basket

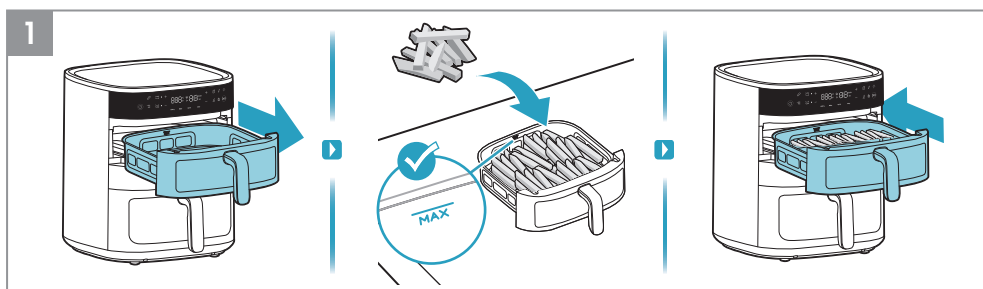

1. Firstly, pull out the top basket and put the food in the basket, for example, french fries.

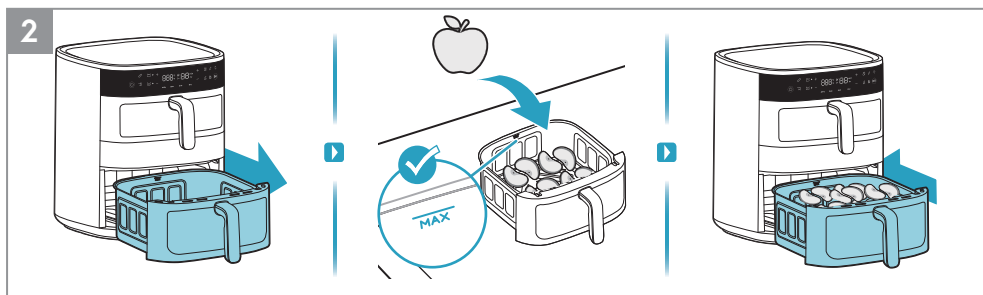

2. Secondly, pull out the bottom basket and put the food in the basket, for example, apple slices.



3. Press the On/Off button. First select the top basket. Then select your desired cooking method, for example, Air Fry function. Adjust the time and temperature to your taste or select one of the pre-set recipes, for example, Vegetable. At last, press the Play/Pause button.



4. Secondly, select the bottom basket. Then select your desired cooking method, for example, Dry function. Adjust the time and temperature to your taste. At last, press the Play/Pause button.

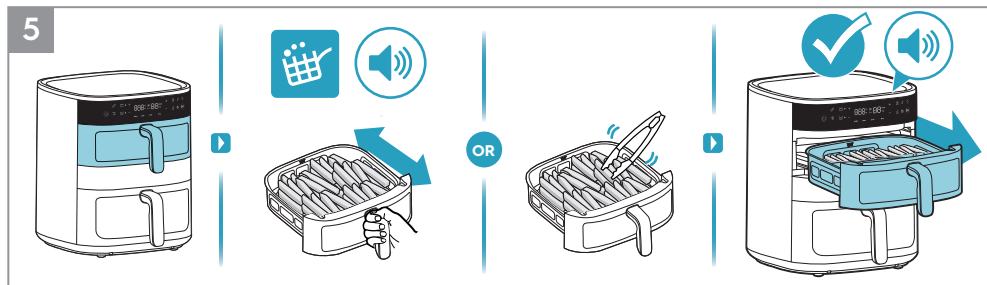

5. When the "Shake Reminder" icon lights up and beeps during the cooking process, use heat-resistant tools to flip the food once or carefully shake the food in the frying basket slightly. At the end of the top basket cooking time, the appliance will issue a beep signal.

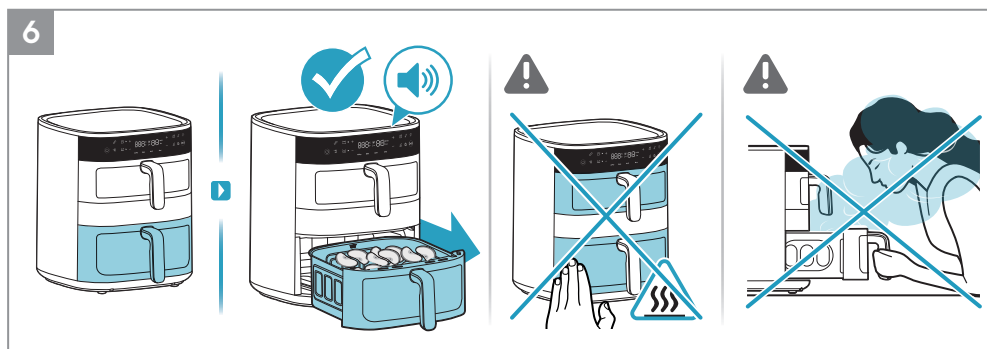

6. At the end of the bottom basket cooking time, the appliance will issue a beep signal.

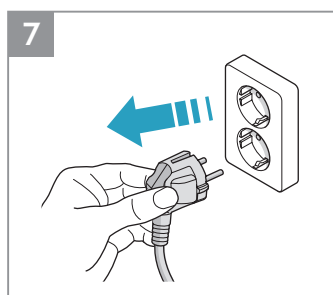

7. Unplug the appliance after using it.

How to use - Link function

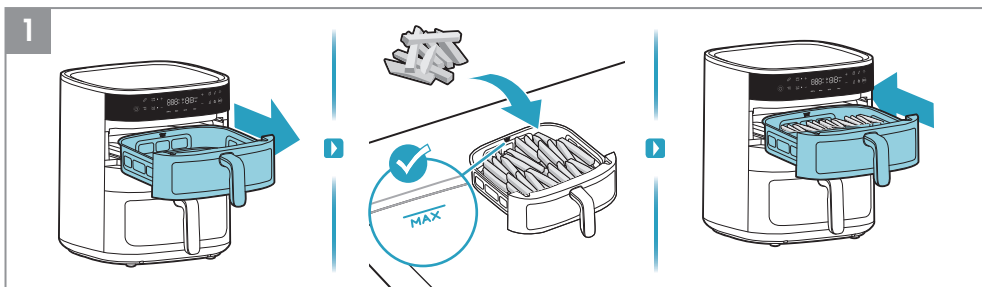

1. Firstly, pull out the top basket and put the food in the basket, for example, french fries.

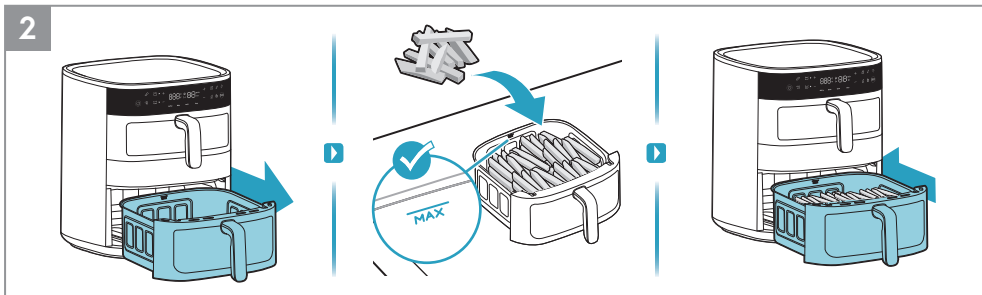

2. Secondly, pull out the bottom basket and put the food in the basket, for example, french fries.



3. Press the On/Off button. First select the link function. Then select your desired cooking method, for example, Air Fry function. Adjust the time and temperature to your taste or select one of the pre-set recipes. At last, press the Play/Pause button.

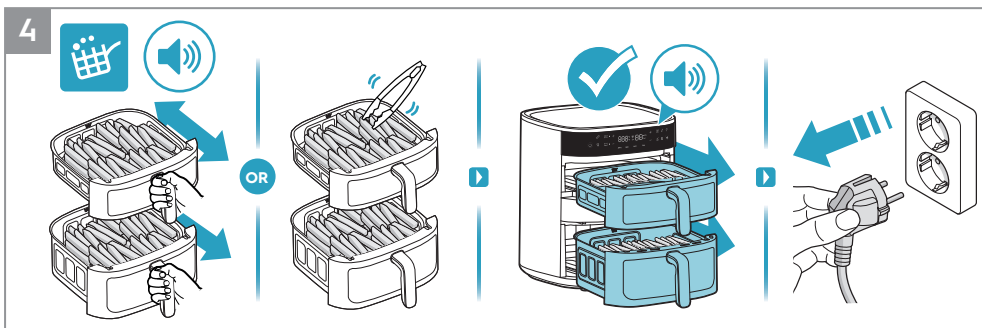

4. When the "Shake Reminder" icon lights up and beeps during the cooking process, use heat-resistant tools to flip the food once or carefully shake the food in the frying basket slightly. At the end of the cooking time, the appliance will issue a beep signal. Unplug the appliance after using it.

EN

BG

CZ

DE

DK

EE

FI

FR

GR

HR

HU

IT

LT

LV

NO

NL

PL

PT

RO

RU

SE

SI

SK

SR

TR

UA

ES

GE

AL

How to use - Sync End function

EN

BG

CZ

DE

DK

EE

FI

FR

GR

HR

HU

IT

LT

LV

NO

NL

PL

PT

RO

RU

SE

SI

SK

SR

TR

UA

ES

GE

AL

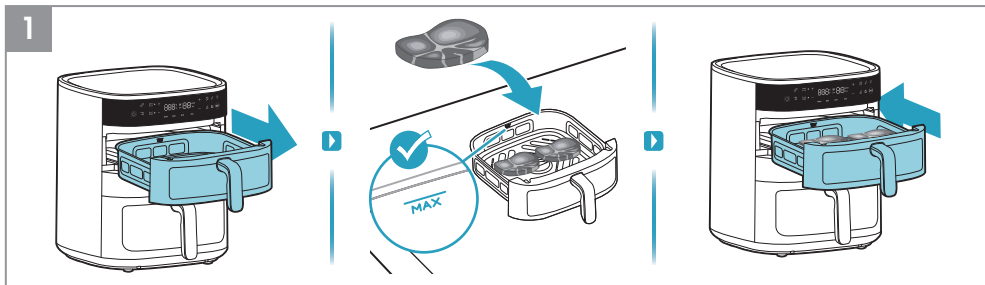

1. Firstly, pull out the top basket and put the food in the basket, for example, steak.

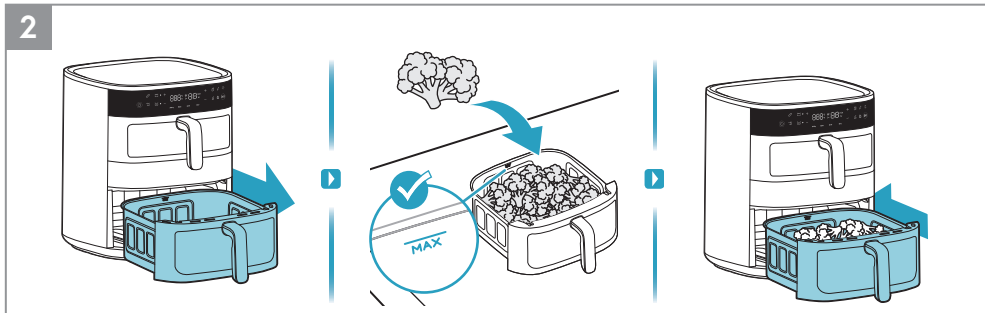

2. Secondly, pull out the bottom basket and put the food in the basket, for example, broccoli.



3. Press the On/Off button. Select the Sync End function. First select the top basket, then select your desired cooking method, for example, Air Fry function. Adjust the time and temperature to your taste or select one of the pre-set recipes, for example, Steak.

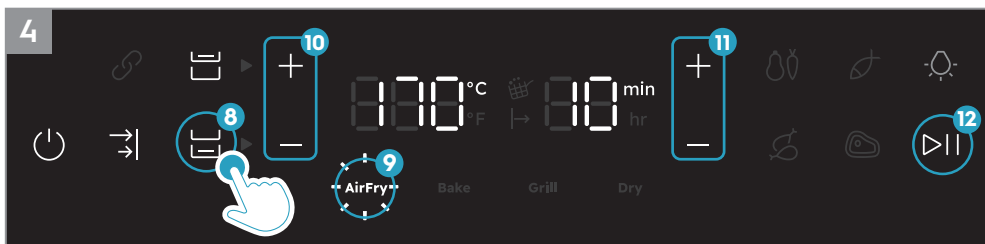

4. And then select the bottom basket, select your desired cooking method, for example, Air Fry function. Adjust the time and temperature to your taste or select one of the pre-set recipes. At last, press the Play/Pause button.

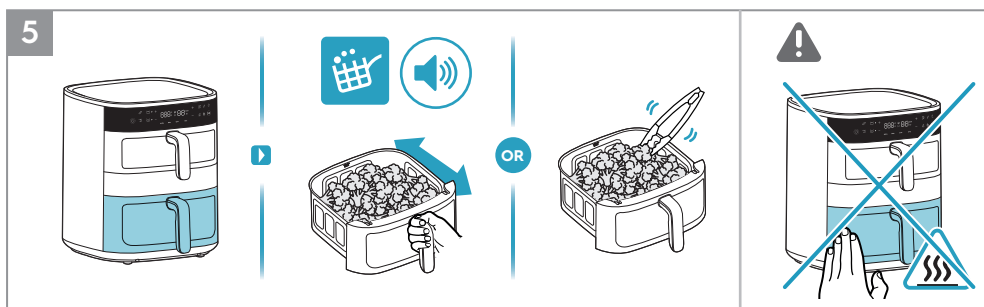

5. Firstly, bottom basket with longer setting time will be prioritized for cooking. When the "Shake Reminder" icon lights up and beeps during the cooking process, use heat-resistant tools to flip the food once or carefully shake the food in the frying basket slightly.

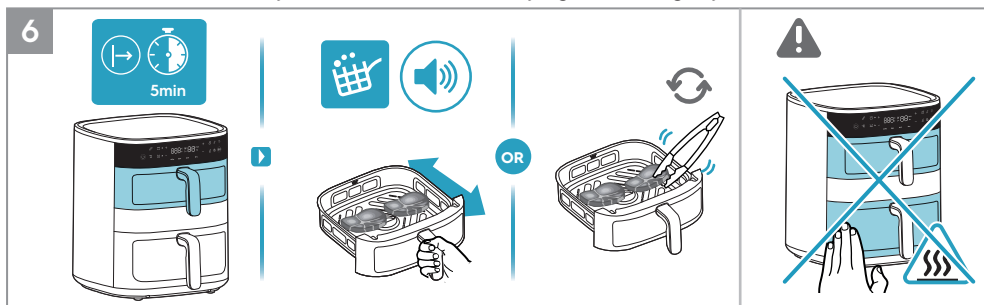

6. Secondly, top basket with shorter setting time will start cooking. When the "Shake Reminder" icon lights up and beeps during the cooking process, use heat-resistant tools to flip the food once or carefully shake the food in the frying basket slightly.

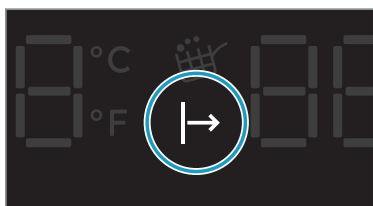

Waiting to cooking indicator

When the "Sync end function" is activated, the basket with shorter cooking time will wait for cooking until the basket with longer cooking time cooking for a while, so that both baskets can end cooking at the same time. During this period, the "waiting to cooking indicator" will light up until cooking begins.

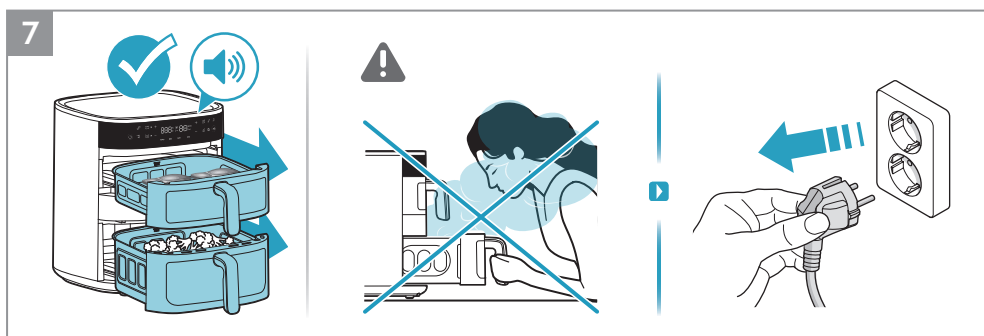

7. At the end of the cooking time, the appliance will issue a beep signal. Unplug the appliance after using it.

Cleaning

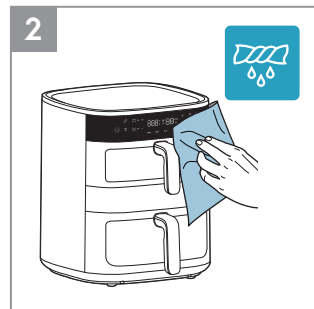
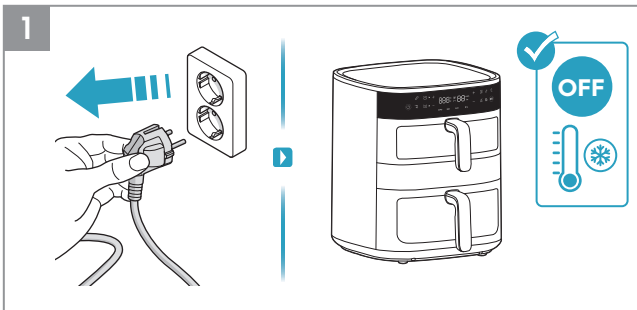

1. Always unplug the appliance and wait until it cools down before cleaning it.
2. Wipe the outside of the appliance with a soft cloth.

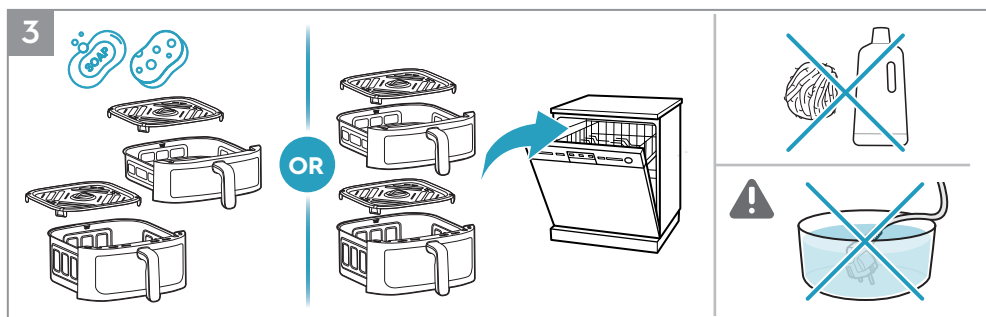

3. Clean the pan and grid with warm water and dish soap, or place them in the dishwasher.

NOTE: Avoid using abrasive cleaning products or metal tools in order to protect the non-stick coating.



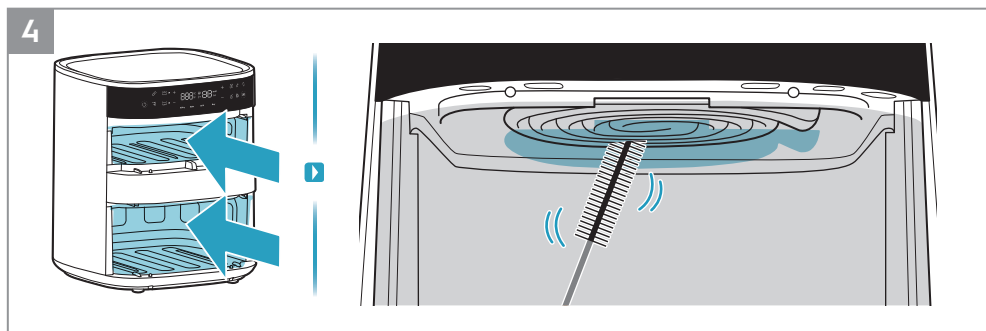









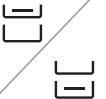















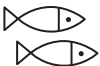









CAUTION: Never submerge the product, its cord or plug in water or any other liquid.



4. Clean the heating element with a cleaning brush.

NOTE: Ensure the appliance is completely cooled down before cleaning the heating element.

Cooking Guide

							
AirFry	7mm/10mm 	4L 	400g	180°C	18min		
		7L 	400g	180°C	18min		
AirFry		4L 	400g	170°C	8min		
		7L 	400g	170°C	10min		
AirFry		4L 	400g/2pcs	140°C	15min		
		7L 	400g/2pcs	140°C	15min		
AirFry		4L 	1000g/8pcs	180°C	28min		
		7L 	1000g/8pcs	180°C	28min		
AirFry		4L 	400g/2pcs	200°C	10min		
		7L 	400g/2pcs	200°C	10min		
AirFry		4L 	220g/6inches	160°C	12min		
		7L 	220g/6inches	160°C	14min		

EN

BG

CZ

DE

DK

EE

FI

FR

GR

HR

HU

IT

LT

LV

NO

NL

PL

PT

RO

RU

SE

SI

SK

SR



































TR

UA

ES

GE

AL

							
		 7L	1200g	180°C	55min		
		 7L	400g/9pcs	160°C	20min		
		 4L	180g/4pcs	180°C	8min		
		 7L	180g/4pcs	180°C	9min		
		 4L	180g	80°C	3h		
		 7L	180g	80°C	3h		
		 4L	200g	80°C	3h		
		 7L	200g	80°C	3h		

What to do if...

Problem	Check if...
You cannot activate or operate the appliance.	<ul style="list-style-type: none"> • The appliance is correctly connected to an electrical supply. • The baskets are in the correct position. Ensure they are completely pushed into the appliance to enable the electrical supply. • The cooking time is set.
You cannot slide the basket into the appliance.	<ul style="list-style-type: none"> • The basket is filled over its maximum capacity. • The basket is placed correctly. It has to click when you place it in the unit. • There's an object under the basket that is an obstacle to close it properly.
White smoke comes out of the appliance.	<ul style="list-style-type: none"> • The food you prepare is too greasy. • The basket, grid and heating element are clean.
The display shows E1	• Top bucket open circuit
The display shows E2	• Top bucket short circuit
The display shows E3	• Bottom bucket open circuit
The display shows E4	• Bottom bucket short circuit
The display shows E5	• Control PCBA communication failure.
The display shows E6	• Power PCBA communication failure.

* In case the display shows error codes, the appliance must be repaired by a Service Center.

Technical Data

Product	Air Fryer
Model	EAFD11B
Voltage (V~)	220 V - 240 V
Power (W)	2700 W
Frequency (Hz)	50 ~ 60 Hz
Capacity	4 L + 7 L

EN

BG

CZ

DE

DK

EE

FI

FR

GR

HR

HU

IT

LT

LV

NO

NL

PL

PT

RO

RU

SE

SI

SK

SR

TR

UA

ES

GE

AL



Книжка с указания

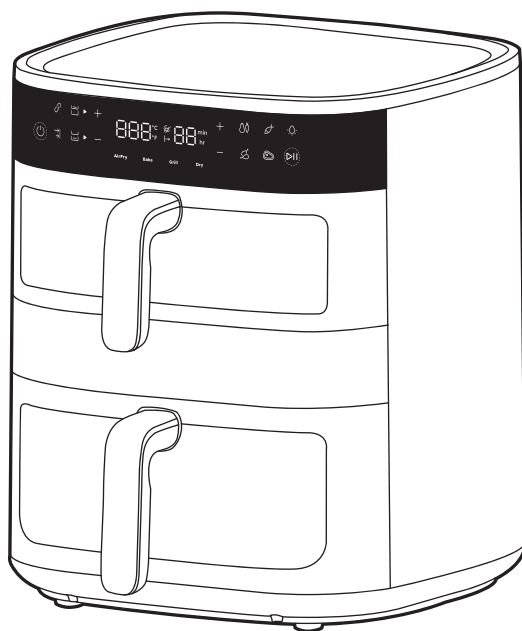

Двоен Еър фраер 800 (800 Air Fryer Dual)

Общ преглед

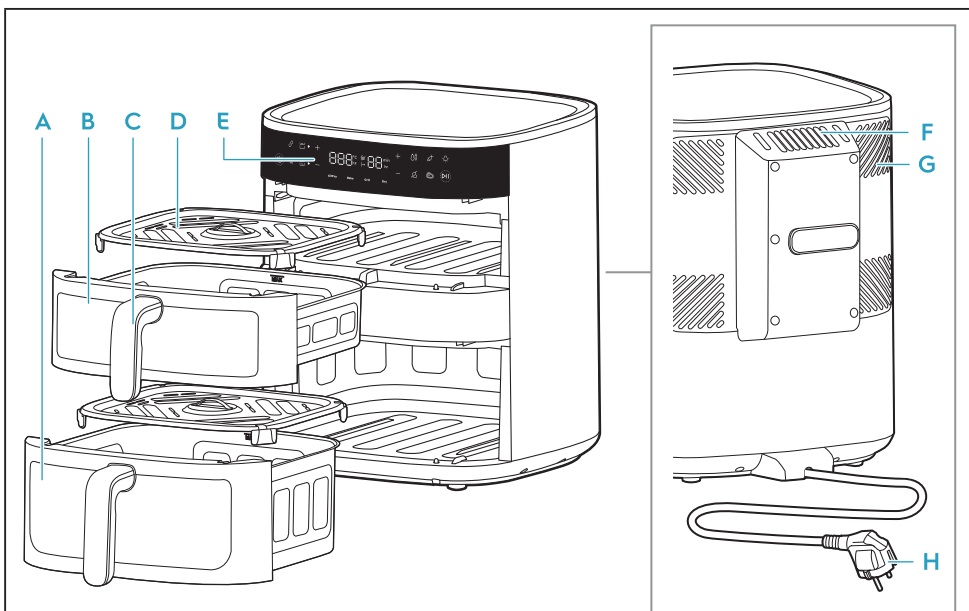

- A** Долна кошница (7л) **C** Дръжка на кошницата **E** Контролен панел **G** Система за охлаждане
B Горна кошница (4л) **D** Решетка **F** Изход за въздуха **H** Основен кабел

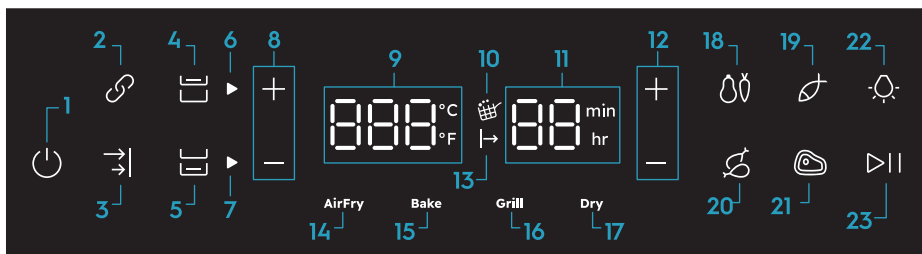

- | | | | |
|-------------------------------------|--|--|-----------------------------|
| 1. Вкл./Изкл. | 6. Индикатор на горната кошница | 10. Напомняне за разклащане | 16. Функция за грил |
| 2. Функция "Връзка" | 7. Индикатор на долната кошница | 11. Индикатор за време (AirFry: 1-99 мин, Дехидратиране: 1-5 ч.) | 17. Функция за сушене |
| 3. Функция "Синхронизиране на края" | 8. Контрол на температурата | 12. Контрол на времето | 18. Зеленчуци |
| 4. Контрол на горната кошница | 9. Индикатор за температурата (40-200°C) | 13. Изчакване на готвенето | 19. Риба |
| 5. Контрол на долната кошница | | 14. Функция "AirFry" | 20. Пиле |
| | | 15. Функция за печене | 21. Пържола |
| | | | 22. Контрол на осветлението |
| | | | 23. Пускане/Пауза |

Преди да използвате за първи път

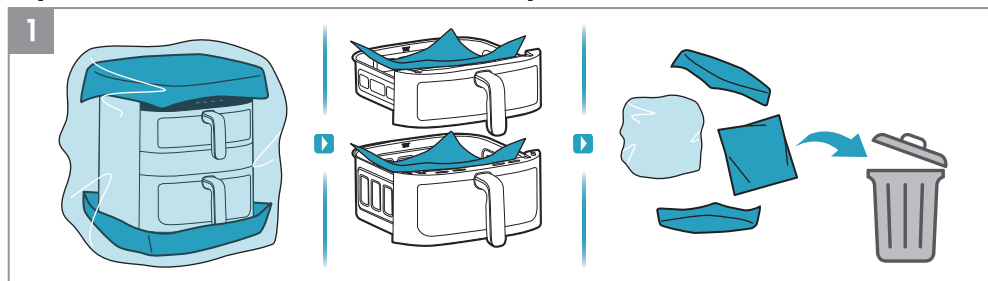

1. Премахнете всички опаковки и защитния материал.

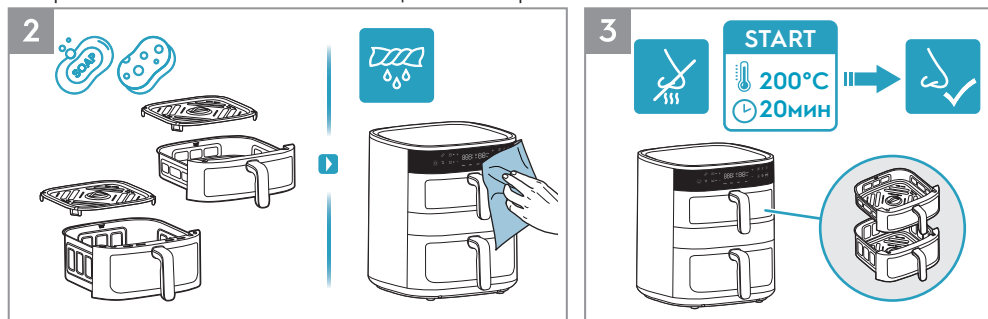



2. Почистете тавичката и решетката с топла вода и препарат за миене на съдове. Избършете вътрешността и външността на уреда с мека кърпа.

3. Нормално е нов уред да излъчва миризми при първите няколко използвания. За да избегнете това, пуснете празния еър фраер на 200 °C за 20 минути преди да го използвате за първи път.

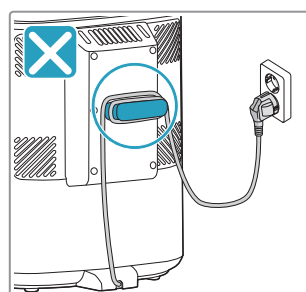
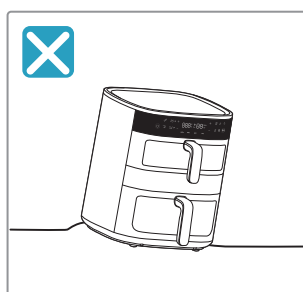
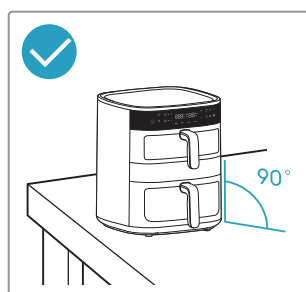
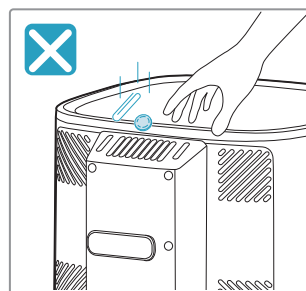
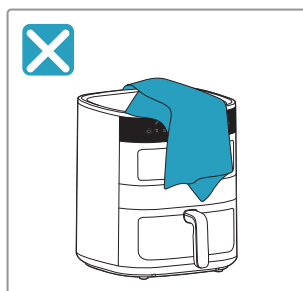
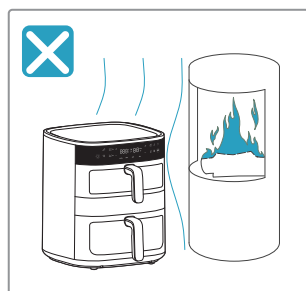



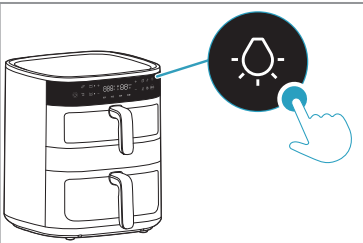
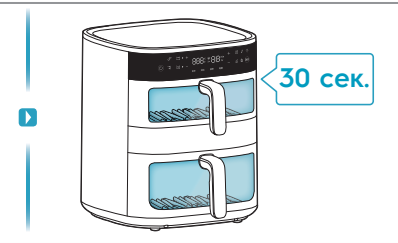

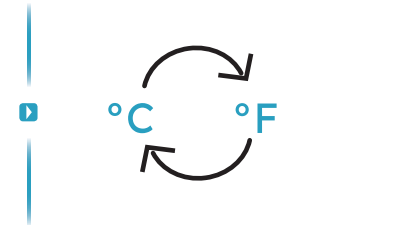







⚠ Мерки за безопасност



Контрол на осветлението и преобразуване на температурната скала

 <p>Контрол на осветлението</p>		 <p>30 сек.</p>
<p>°C/°F</p> <p>Преобразуване на температурната скала</p>	 <p>30 сек.</p>	

Избор на кошница

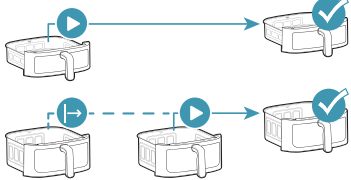
	 <p>4л</p>	 <p>7л</p>	
 <p>Горна кошница</p>			
 <p>Долна кошница</p>			
 <p>Функция "Връзка"</p>			
 <p>Функция "Синхронизиране на края"</p>			

EN

BG

CZ

DE

DK

EE

FI

FR

GR

HR

HU

IT

LT

LV

NO

NL

PL

PT

RO

RU

SE

SI

SK

SR

TR

UA















ES

GE

AL

EN
 BG
 CZ
 DE
 DK
 EE
 FI
 FR
 GR
 HR
 HU
 IT
 LT
 LV
 NO
 NL
 PL
 PT
 RO
 RU
 SE
 SI
 SK
 SR
 TR
 UA
 ES
 GE
 AL

Предварително зададени функции

					
Air Fry	180°C	15мин	60-200°C	1-99мин	
	170°C	10мин	60-200°C	1-99мин	
	140°C	15мин	60-200°C	1-99мин	
	180°C	30мин	60-200°C	1-99мин	
	200°C	10мин	60-200°C	1-99мин	
Bake	170°C	15мин	60-200°C	1-99мин	
Grill	200°C	5мин	60-200°C	1-99мин	
Dry	80°C	5ч	40-80°C	1-5ч	

Преди готвенето

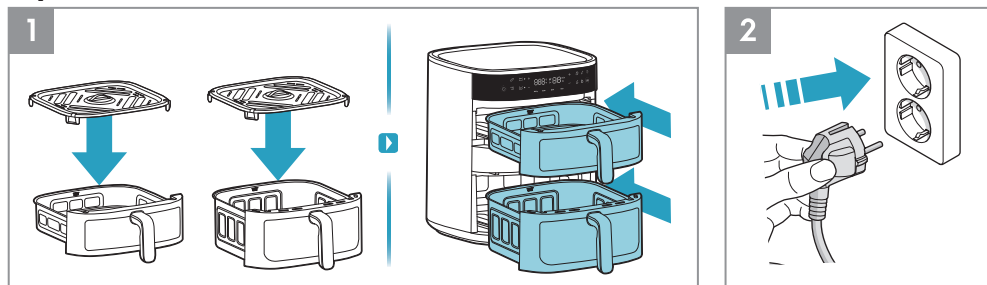

1. Преди всяко готвене поставете решетката в кошницата (не е необходимо да се отстранява термоустойчивата силиконова подложка на решетката) и изцяло вкарайте кошницата в уреда.
2. Включете щепсела в електрическата мрежа.

Как да използвате - Само едната кошница

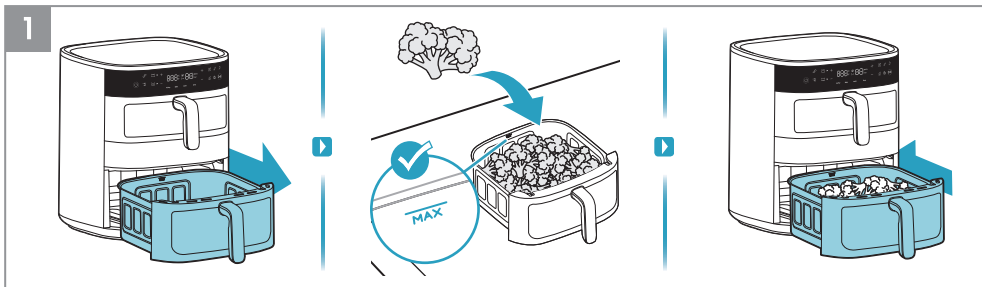

1. Извадете една кошница и я поставете върху стабилна повърхност, сложете храната в кошницата, като спазвате указанията за максималния капацитет. След това вкарайте кошницата с храната изцяло в уреда.

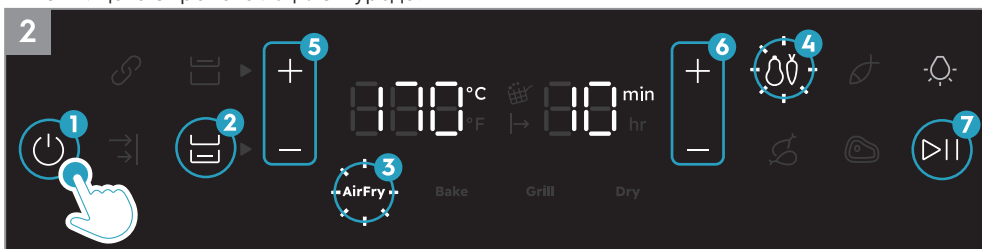

2. Натиснете бутона Вкл./Изкл. Първо изберете кошницата с храната. След това изберете желаните метод на готвене, например функцията „Air Fry“. Настройте времето и температурата според своя вкус или изберете една от предварително зададените рецепти, например Зеленчуци. Накрая натиснете бутона Пускане/Пауза.

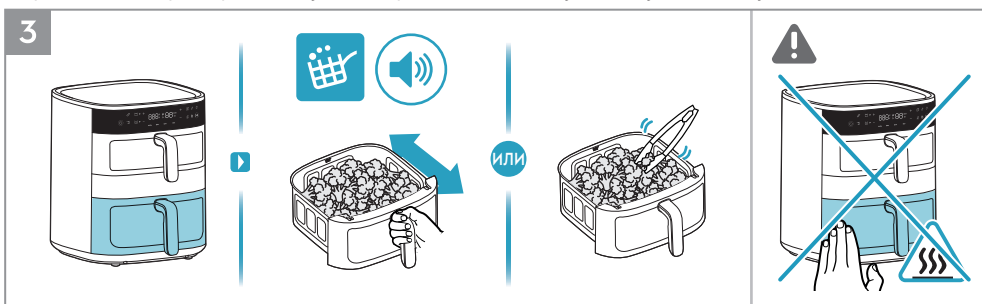

3. Когато иконата Напомняне за разклащане светне и се чуе звук от сигнал по време на готвенето, използвайте термоустойчиви прибори, за да обърнете храната веднъж или внимателно разклатете леко храната в кошницата за пържене.

⚠ **ВНИМАНИЕ:** Не разклащайте кошницата за пържене енергично, за да избегнете пръски от храна и изгаряния.

⚠ **ВНИМАНИЕ:** Внимавайте с горещите повърхности когато използвате уреда.

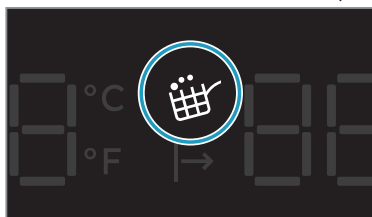

Напомняне за разклащане

“Напомнянето за разклащане” се активира по време на функцията “Air Fry” и предварително зададените рецепти, като зеленчуци, риба, пилешки бутчета и пържола.

Когато е време да разклатите или обърнете храната, иконата “Напомняне за разклащане” ще светне и ще мига в продължение на една минута, а звуковият сигнал ще се повтори три пъти.

“Напомнянето за разклащане” не е задължително, затова готвенето ще продължи както обикновено, дори ако храната не бъде обърната или разклатена.

EN

BG

CZ

DE

DK

EE

FI

FR

GR

HR

HU

IT

LT

LV

NO

NL

PL

PT

RO

RU

SE

SI

SK

SR

TR

UA

ES

GE

AL



4. В края на времето за готвене уредът ще издаде звуков сигнал. Внимателно извадете кошницата и я поставете върху топлоустойчива повърхност. След употреба изключете уреда от контакта.

⚠ **ВНИМАНИЕ:** Когато отворите кошницата по време на готвенето или в края му, от нея може да излезе гореща пара. Уверете се, че лицето и ръцете ви са далеч от парата, когато я отваряте.

Как да използвате - горна + долна кошница

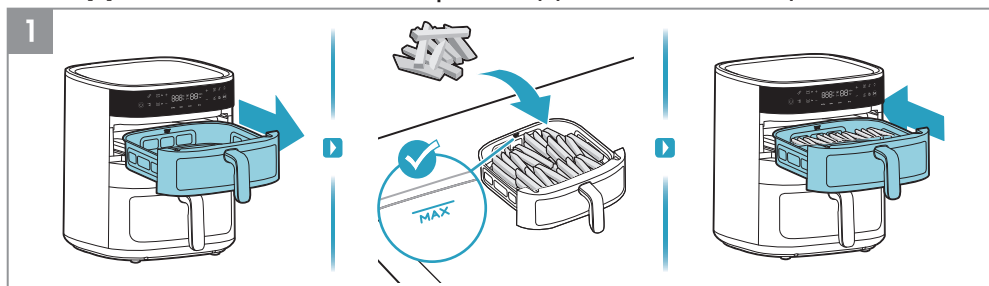

1. Първо извадете горната кошница и сложете храната в нея, например пържени картофи.

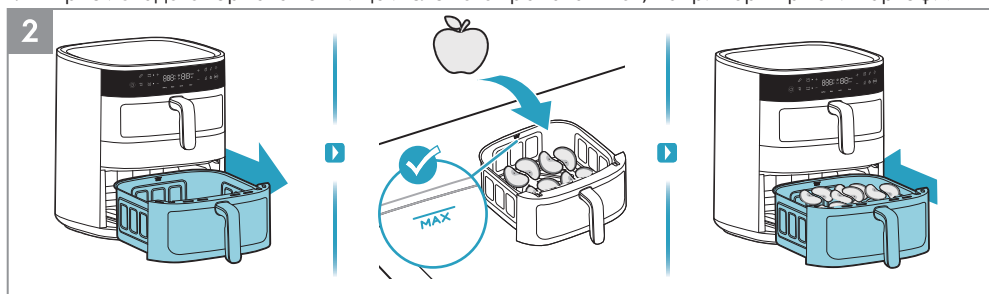

2. Второ, извадете долната кошница и сложете в нея храната, например резени ябълка.



3. Натиснете бутона Вкл./Изкл. Първо изберете горната кошница. След това изберете желания метод на готвене, например функцията "Air Fry". Настройте времето и температурата според своя вкус или изберете една от предварително зададените рецепти, например Зеленчуци. Накрая натиснете бутона Пускане/Пауза.



4. Второ, изберете долната кошница. След това изберете желания метод на готвене, например функция "Сушене". Настройте времето и температурата според своите предпочитания. Накрая натиснете бутона Пускане/Пауза.

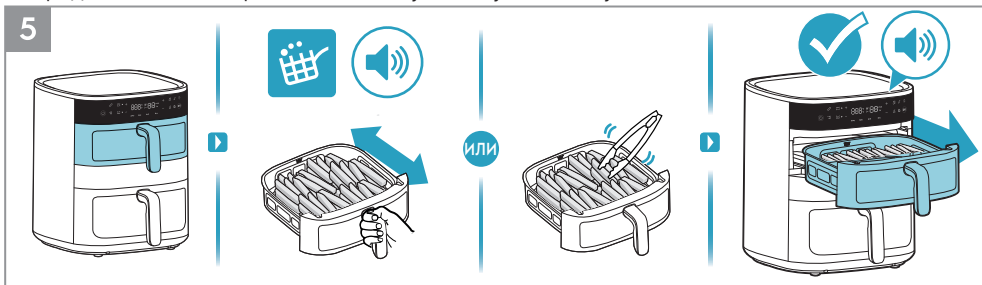

5. Когато иконата Напомняне за разклащане светне и се чуе звук сигнал по време на готвенето, използвайте термоустойчиви прибори, за да обърнете храната веднъж или внимателно разклатете леко храната в кошницата за пържене. В края на времето за готвене на горната кошница уредът ще издаде звуков сигнал.

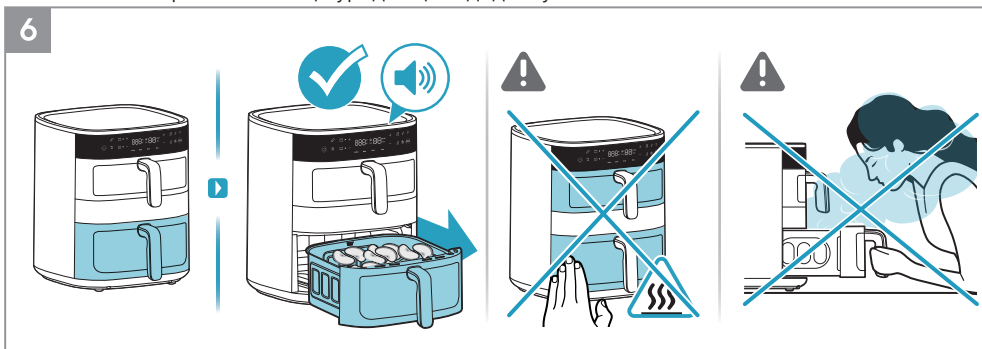

6. В края на времето за готвене на долната кошница уредът ще издаде звуков сигнал.

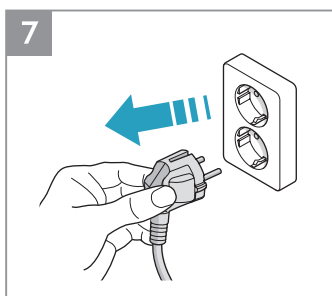

7. След употреба изключете уреда от контакта.

EN

BG

CZ

DE

DK

EE

FI

FR

GR

HR

HU

IT

LT

LV

NO

NL

PL

PT

RO

RU

SE

SI

SK

SR

TR

UA

ES

GE

AL

Как да използвате - Функция "Връзка"

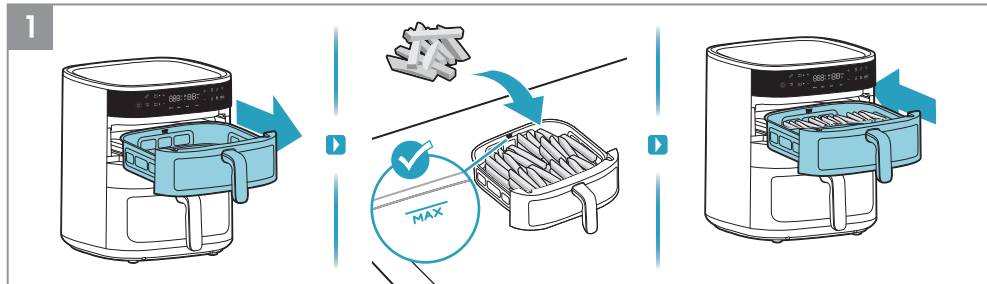

1. Първо извадете горната кошница и сложете храната в нея, например пържени картофи.

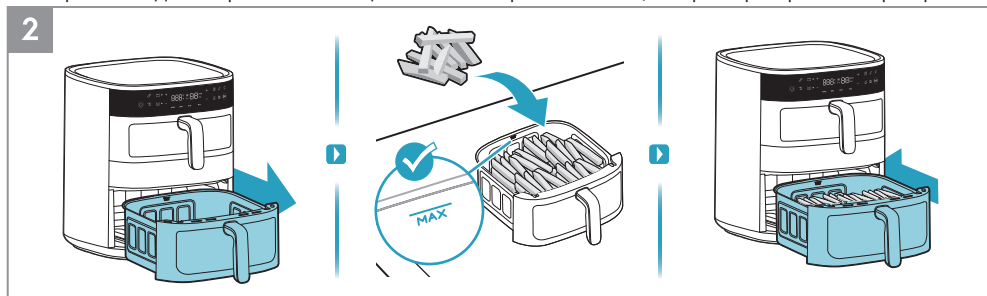

2. Второ, извадете долната кошница и сложете в нея храната, например пържени картофи.



3. Натиснете бутона Вкл./Изкл. Първо изберете функцията "Връзка". След това изберете желаня метод на готвене, например функцията "Air Fry". Настройте времето и температурата според своя вкус или изберете една от предварително зададените рецепти. Накрая натиснете бутона Пускане/Пауза.

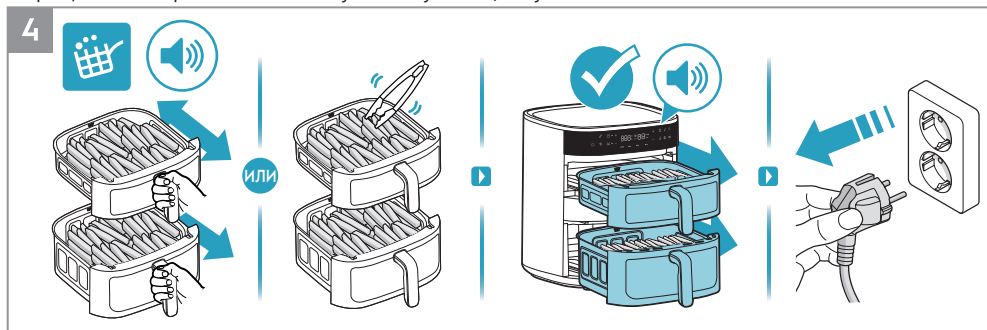

4. Когато иконата Напомняне за разклащане светне и се чуе звуков сигнал по време на готвенето, използвайте термоустойчиви прибори, за да обърнете храната веднъж или внимателно разклатете леко храната в кошницата за пържене. В края на времето за готвене уредът ще издаде звуков сигнал. След употреба изключете уреда от контакта.

Как да използвате - Функция "Синхронизиране на края"

EN
BG
CZ
DE
DK
EE
FI
FR
GR
HR
HU
IT
LT
LV
NO
NL
PL
PT
RO
RU
SE
SI
SK
SR
TR
UA
ES
GE
AL

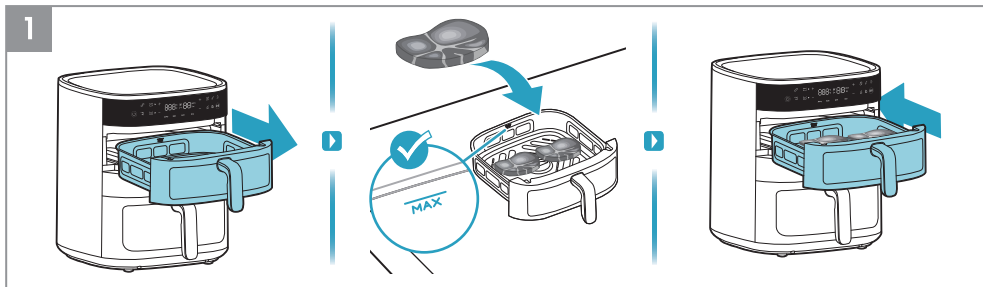

1. Първо извадете горната кошница и сложете храната в нея, например пържола.

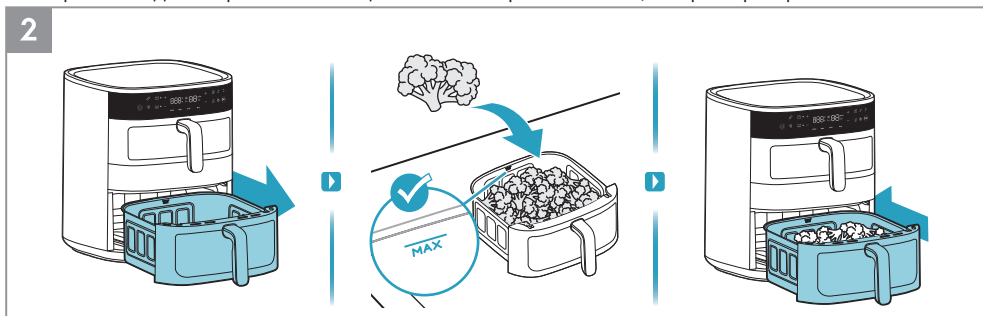

2. Второ, извадете долната кошница и сложете храната в нея, например броколи.



3. Натиснете бутона Вкл./Изкл. Изберете функция "Синхронизиране на края". Първо изберете горната кошница, след това изберете желанния начин на готвене, например функцията "Air Fry". Настройте времето и температурата според своя вкус или изберете една от предварително зададените рецепти, например за пържола.



4. След това изберете долната кошница и желанния начин на готвене, например функцията "Air Fry". Настройте времето и температурата според своя вкус или изберете една от предварително зададените рецепти. Накрая натиснете бутона Пускане/Пауза.

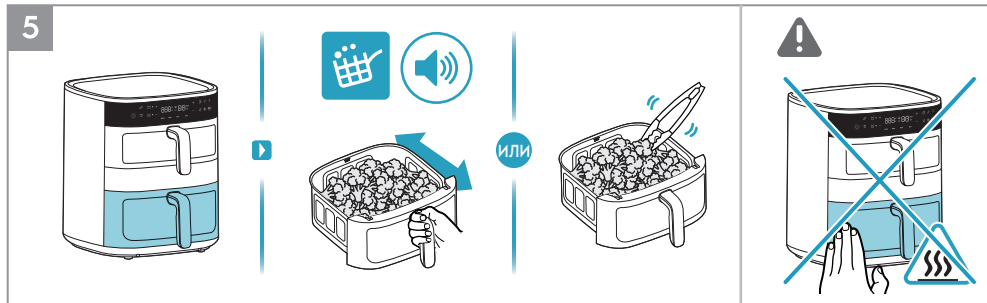

5. Първо, долната кошница с по-дълго настроено време за готвене ще бъде с приоритет. Когато иконата Напомняне за разклащане светне и се чуе звуков сигнал по време на готвенето, използвайте термоустойчиви прибори, за да обърнете храната веднъж или внимателно разклатете леко храната в кошницата за пържене.

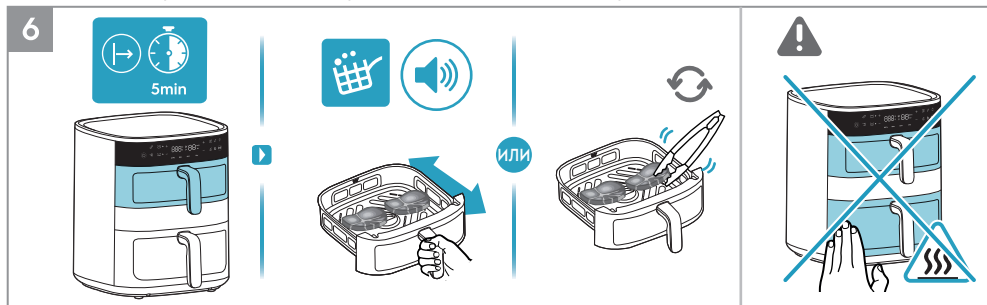

6. Второ, горната кошница с по-кратко настроено време за готвене ще започне да се готви. Когато иконата Напомняне за разклащане светне и се чуе звуков сигнал по време на готвенето, използвайте термоустойчиви прибори, за да обърнете храната веднъж или внимателно разклатете леко храната в кошницата за пържене.

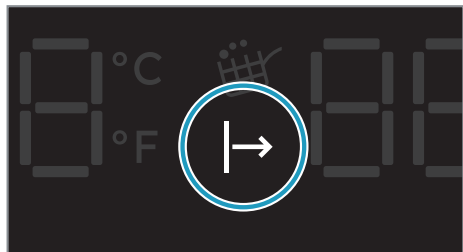

Индикатор за изчакване на готвенето

Когато функцията "Синхронизиране на края" е активирана, кошницата с по-кратко време за готвене ще изчака, докато кошницата с по-дълго време за готвене се готви за известно време, така че и двете кошници да могат да приключат готвенето едновременно. През това време индикаторът "изчакване на готвенето" ще свети, докато готвенето не започне.

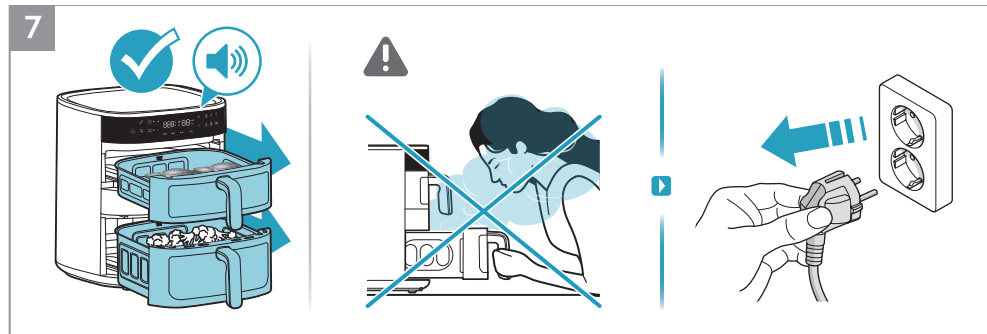

7. В края на времето за готвене уредът ще издаде звуков сигнал. След употреба изключете уреда от контакта.

Почистване

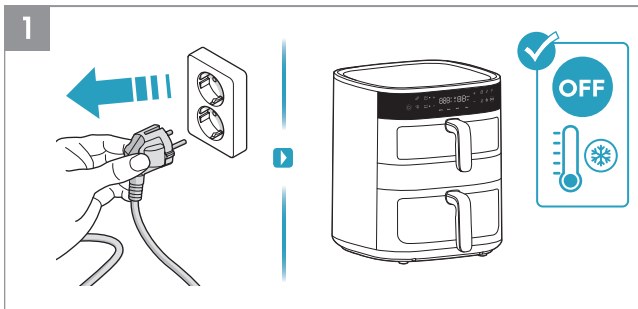

1. Винаги изключвайте уреда от електрическата мрежа и изчакайте да изстине, преди да го почистите.
2. Избършете външната част на уреда с мека кърпа.

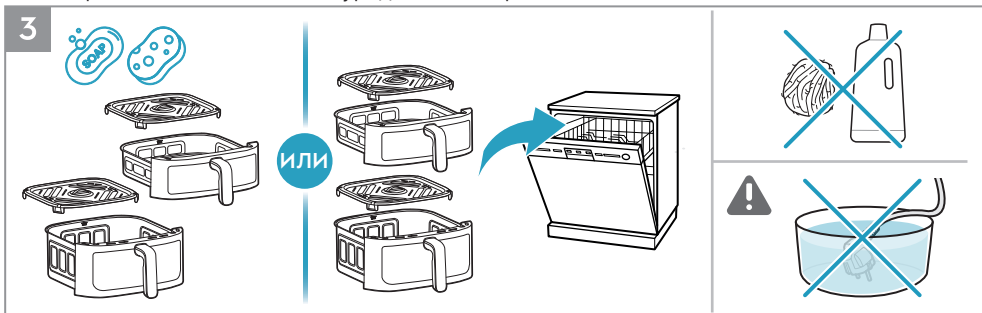
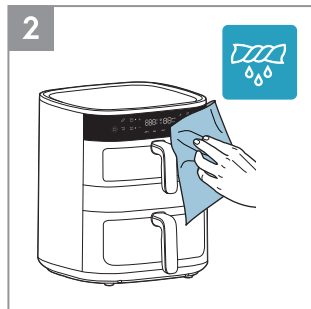

3. Почистете тавичката и решетката с топла вода и препарат за миене на съдове или ги сложете в съдомиялната.

▲БЕЛЕЖКА: Избягвайте да използвате абразивни почистващи продукти или метални инструменти, за да предпазите незалепащото покритие.

ВНИМАНИЕ: Никого не потапяйте продукта, кабела или щепсела му във вода или друга течност.

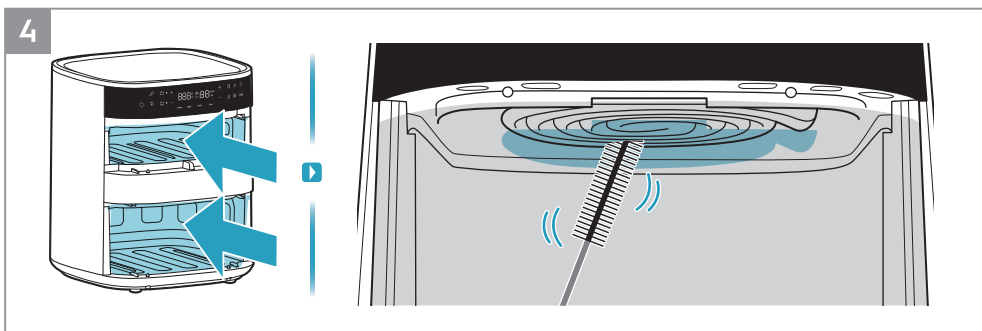

4. Почистете нагревателния елемент с четка за почистване.

БЕЛЕЖКА: Уверете се, че уредът е напълно изстинал, преди да почистите нагревателния елемент.

EN

BG

CZ

DE

DK

EE

FI

FR

GR

HR

HU

IT

LT

LV

NO

NL

PL

PT

RO

RU

SE

SI

SK

SR

TR













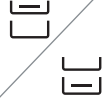























UA





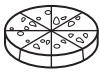







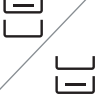











ES

GE

AL

Ръководство за готвене

								
AirFry	7mm/10mm 	 4л	400г	180°C	18мин			
		 7л	400г	180°C	18мин			
AirFry		 4л	400г	170°C	8мин			
		 7л	400г	170°C	10мин			
AirFry		 4л	400г/2 бр.	140°C	15мин			
		 7л	400г/2 бр.	140°C	15мин			
AirFry		 4л	1000г/8 бр.	180°C	28мин			
		 7л	1000г/8 бр.	180°C	28мин			
AirFry		 4л	400г/2 бр.	200°C	10мин			
		 7л	400г/2 бр.	200°C	10мин			
AirFry		 4л	220г/6 инча	160°C	12мин			
		 7л	220г/6 инча	160°C	14мин			

							
AirFry		 7л	1200г	180°C	55мин		
AirFry		 7л	400г/96р.	160°C	20мин		
Grill		 4л	180г/46р.	180°C	8мин		
		 7л	180г/46р.	180°C	9мин		
Dry		 4л	180г	80°C	3 ч.		
		 7л	180г	80°C	3 ч.		
Dry		 4л	200г	80°C	3 ч.		
		 7л	200г	80°C	3 ч.		

- EN
- BG
- CZ
- DE
- DK
- EE
- FI
- FR
- GR
- HR
- HU
- IT
- LT
- LV
- NO
- NL
- PL
- PT
- RO
- RU
- SE
- SI
- SK
- SR
- TR
- UA
- ES
- GE
- AL

EN

BG

CZ

DE

DK

EE

FI

FR

GR

HR

HU

IT

LT

LV

NO

NL

PL

PT

RO

RU

SE

SI

SK

SR

TR

UA

ES

GE

AL

Какво да направите, ако...

Проблем	Проверете дали...
Не можете да активирате или да работите с уреда.	<ul style="list-style-type: none"> Уредът е правилно свързан към електрическата мрежа. Кошниците са в правилната позиция. Уверете се, че са напълно вкарани в уреда, за да се включи електрозахранването. Времето за готвене е настроено.
Не можете да вкарате кошницата в уреда.	<ul style="list-style-type: none"> Кошницата е напълнена над максималния си капацитет. Кошницата е поставена правилно. Тя трябва да щракне, когато я поставите в устройството. Под кошницата има предмет, който пречи да се затвори правилно.
От уреда излиза бял дим.	<ul style="list-style-type: none"> Приготвяната храна е прекалено мазна. Кошницата, решетката и нагревателният елемент са чисти.
На дисплея се показва E1.	<ul style="list-style-type: none"> Отворена верига на горната тавичка.
На дисплея се показва E2.	<ul style="list-style-type: none"> Къса верига на горната тавичка.
На дисплея се показва E3.	<ul style="list-style-type: none"> Отворена верига на долната тавичка.
На дисплея се показва E4.	<ul style="list-style-type: none"> Къса верига на долната тавичка.
На дисплея се показва E5.	<ul style="list-style-type: none"> Неизправност в комуникацията на контролния РСВА.
На дисплея се показва E6.	<ul style="list-style-type: none"> Неизправност в комуникацията на захранващия РСВА.

* В случай че на дисплея се покажат кодове за грешка, уредът трябва да бъде ремонтиран от сервизен център.

Технически данни

Продукт	Еър Фраер
Модел	EAFD11B
Волтаж (V~)	220 V - 240 V
Захранване (W)	2700 W
Честота (Hz)	50 - 60 Hz
Капацитет	4 л + 7 л



Uživatelská příručka

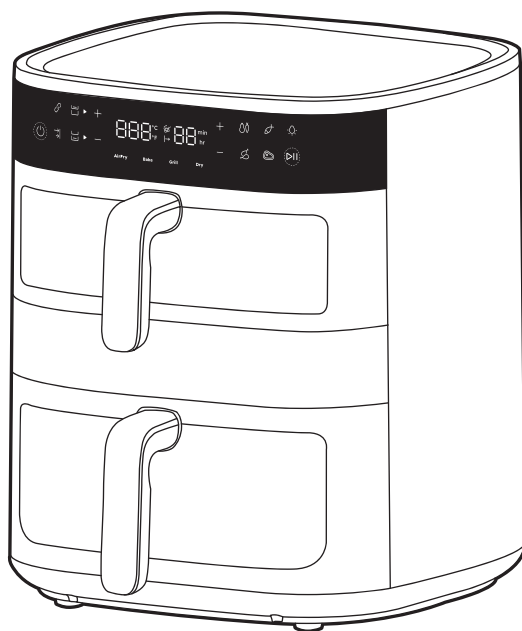

800 Horkovzdušná fritéza se dvěma koši

Celkový pohled

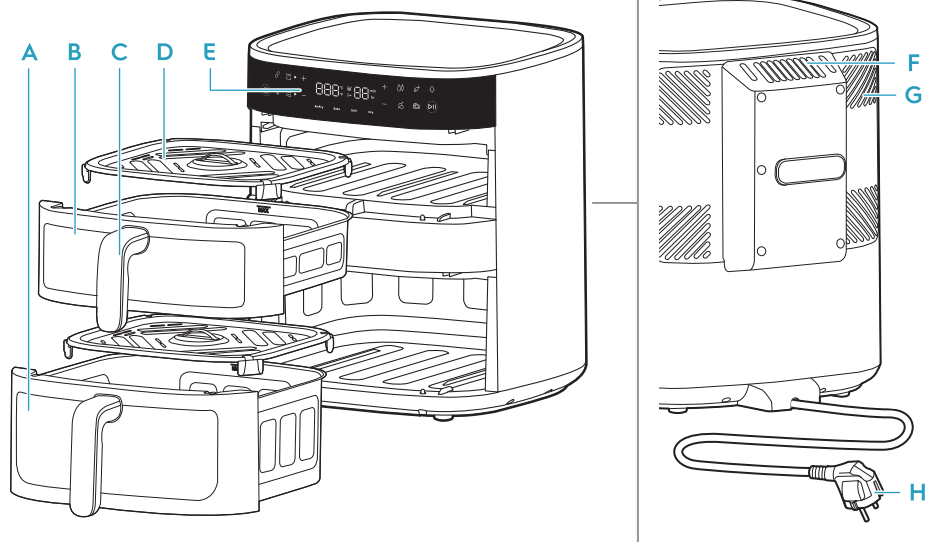

- | | | | |
|---------------------------|-----------------------|-------------------------|--------------------------|
| A Spodní koš (7 l) | C Rukojeť koše | E Ovládací panel | G Chladicí systém |
| B Horní koš (4 l) | D Rošt | F Výstup vzduchu | H Napájecí kabel |

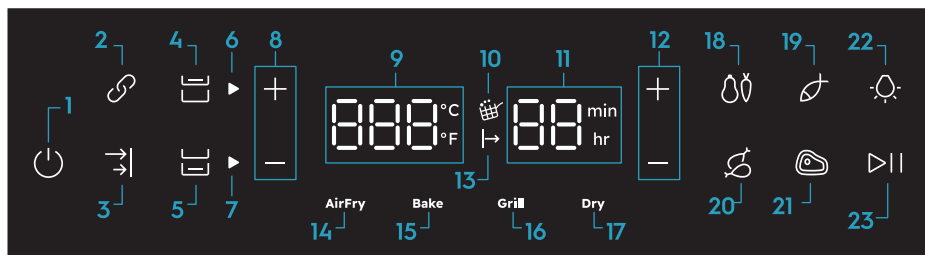

- | | | | |
|----------------------------------|--|-----------------------------------|-------------------------|
| 1. ZAP/VYP | 8. Tlačítko Teplota | 12. Tlačítko Čas | 18. Zelenina |
| 2. Funkce Propojení | 9. Kontrolka teploty (40-200 °C) | 13. Čekání na vaření | 19. Ryba |
| 3. Funkce Synchronizace ukončení | 10. Připomenutí promíchání | 14. Funkce Horkovzdušné fritování | 20. Kuře |
| 4. Tlačítko Horní koš | 11. Kontrolka času (Horkovzdušné fritování: 1-99 min, sušení: 1-5 h) | 15. Funkce Pečení | 21. Steak |
| 5. Tlačítko Spodní koš | | 16. Funkce Grilování | 22. Tlačítko Světlo |
| 6. Kontrolka horního koše | | 17. Funkce Sušení | 23. Spustit/ pozastavit |
| 7. Kontrolka spodního koše | | | |

Před prvním použitím

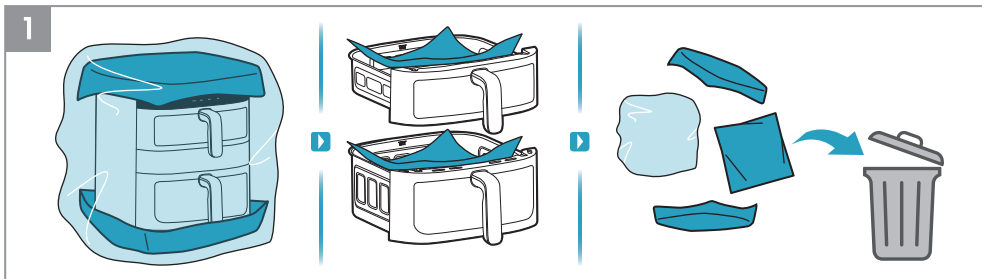

1. Odstraňte veškerý obalový a ochranný materiál.

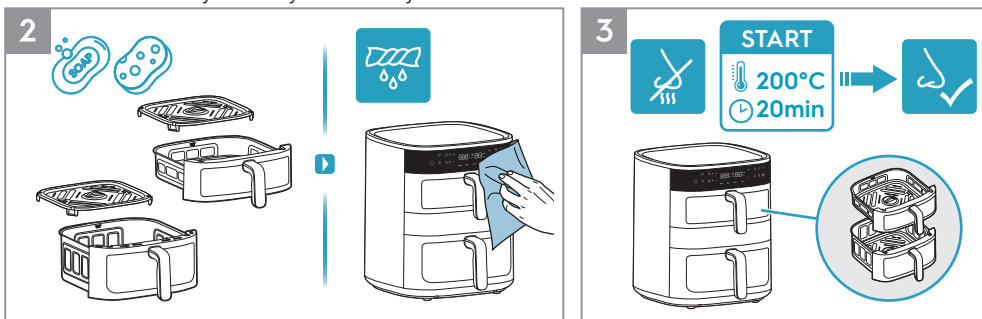

2. Omyjte koš a rošt teplou vodou a prostředkem na mytí nádobí. Otřete vnitřní a vnější povrch spotřebiče měkkou utěrkou.

3. U nového zařízení je normální, že při několika prvních použitích vydává zápach. Zabráňte tomu tak, že před prvním použitím zapnete prázdnou horkovzdušnou fritézu na teplotu 200 °C a necháte ji v chodu 20 minut.

! Bezpečnostní opatření

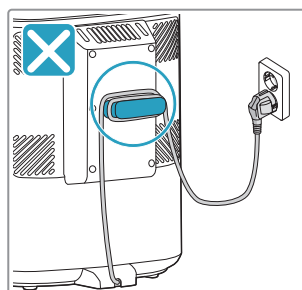
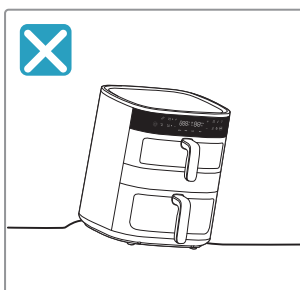
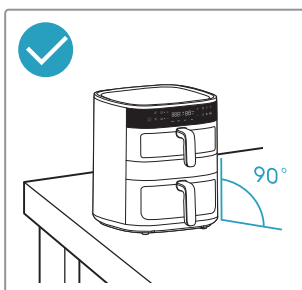
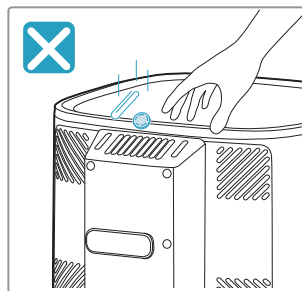
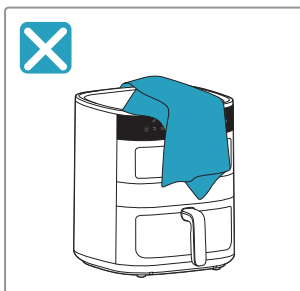
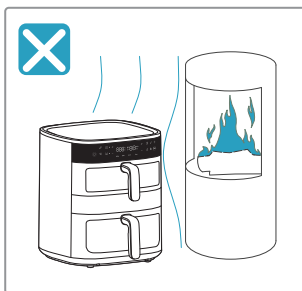





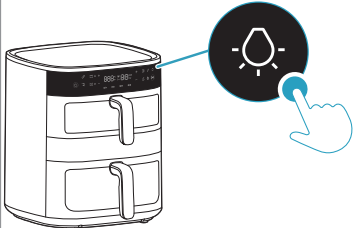
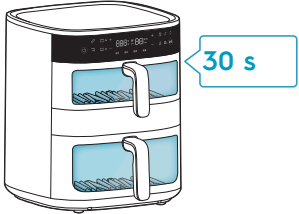
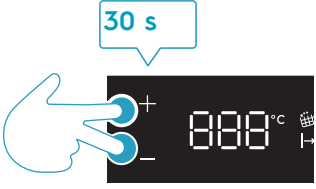
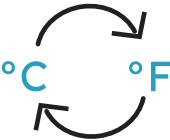









EN
BG
CZ
DE
DK
EE
FI
FR
GR
HR
HU
IT
LT
LV
NO
NL
PL
PT
RO
RU
SE
SI
SK
SR
TR
UA
ES
GE
AL







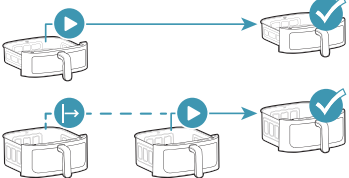







Tlačítko Světlo a přepínání jednotek teploty

 <p>Tlačítko Světlo</p>		
<p>°C/°F</p> <p>Přepínání jednotek teploty</p>		

Výběr koše

	 <p>4l</p>	 <p>7l</p>	
 <p>Horní koš</p>			
 <p>Spodní koš</p>			
 <p>Funkce Propojení</p>			
 <p>Funkce Synchronizace ukončení</p>			

Přednastavené funkce

 AirFry					
AirFry	180°C	15min	60-200°C	1-99min	
	170°C	10min	60-200°C	1-99min	
	140°C	15min	60-200°C	1-99min	
	180°C	30min	60-200°C	1-99min	
	200°C	10min	60-200°C	1-99min	
Bake	170°C	15min	60-200°C	1-99min	
Grill	200°C	5min	60-200°C	1-99min	
Dry	80°C	5h	40-80°C	1-5h	

Před vařením

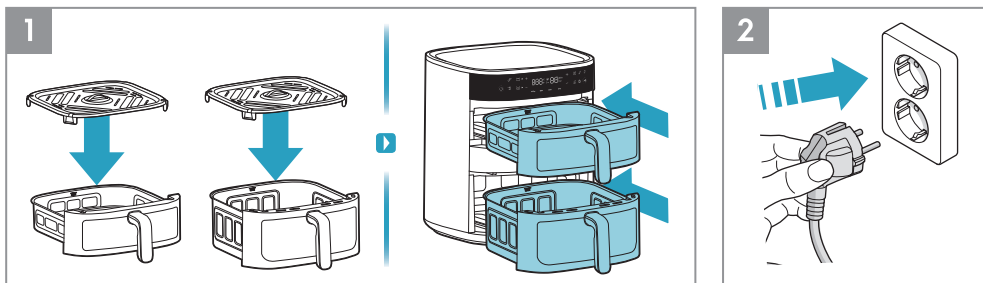

1. Před každým vařením vložte do koše rošt (silikonovou podložku nohy roštu odolnou proti vysoké teplotě není nutné snímat) a koš zasuňte celý do spotřebiče.
2. Zasuňte zástrčku napájecího kabelu do elektrické zásuvky.

Použití – jeden koš

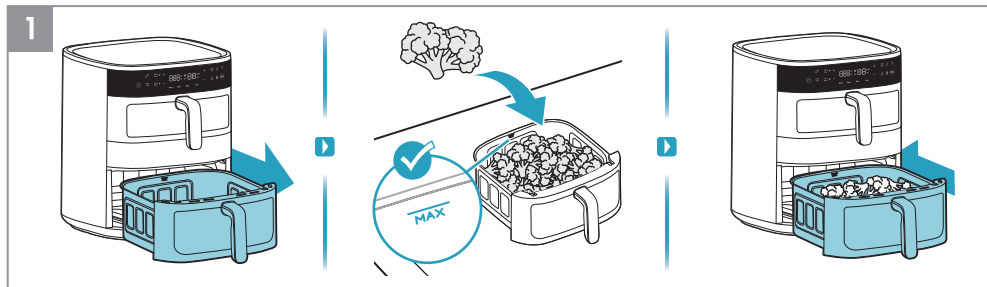

1. Vysuňte jeden koš a položte jej na stabilní povrch. Do koše vložte potraviny, dodržte označenou "MAX." kapacitu. Poté koš s potravinami zasuňte celý zpět do spotřebiče.

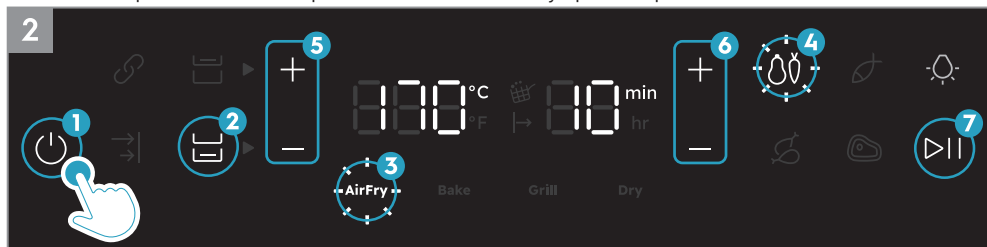

2. Stiskněte tlačítko ZAP/VYP. Nejprve vyberte koš s potravinami. Poté vyberte požadovaný způsob vaření, například funkci Horkovzdušné fritování. Nastavte čas a teplotu tak, jak potřebujete, nebo vyberte jeden z přednastavených receptů, například recept Zelenina. Nakonec stiskněte tlačítko Spustit/pozastavit.

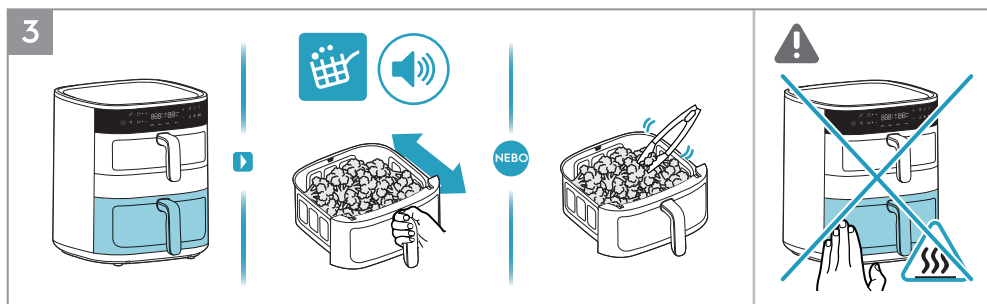

3. Až se během vaření rozsvítí ikona "Připomenutí promíchání" a ozve se zvukový signál, potraviny ve fritovacím koši jednou obraťte nebo opatrně lehce promíchejte pomocí náčiní odolného proti vysoké teplotě.

⚠ **UPOZORNĚNÍ:** Netřepte fritovacím košem energicky, aby potraviny nevypadly a nezpůsobili popáleniny.

⚠ **UPOZORNĚNÍ:** Za chodu spotřebiče dávejte pozor na horké povrchy.

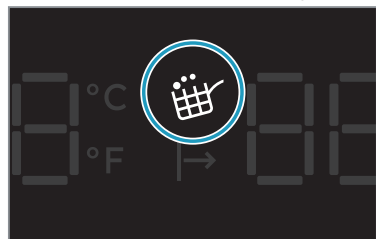

Připomenutí promíchání

"Připomenutí promíchání" se aktivuje v průběhu vaření s funkcí Horkovzdušné fritování a vaření podle přednastavených receptů, například Zelenina, Ryba, Kuře (stehno) a Steak.

Až bude čas potraviny promíchat nebo obrátit, rozsvítí se ikona "Připomenutí promíchání", která bude blikat po dobu jedné minuty, přitom třikrát zazní zvukový signál. Promíchání nebo obrácení po rozsvícení ikony "Připomenutí promíchání" není povinné, takže vaření bude pokračovat dál jako obvykle, i když potraviny neobráťte nebo nepromícháte.

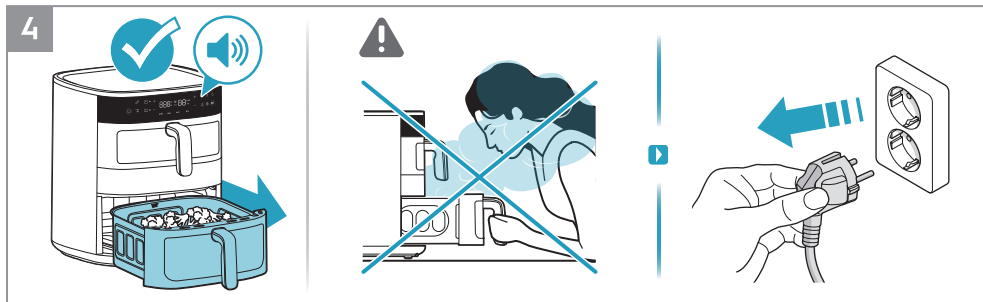

4. Při uplynutí času vaření spotřebič vydá zvukový signál. Opatrně vyjměte koš a položte jej na povrch odolný proti vysoké teplotě. Po použití spotřebiče odpojte zástrčku jeho napájecího kabelu.

⚠ **UPOZORNĚNÍ:** Po otevření koše po uplynutí poloviny času vaření nebo po jeho ukončení může z koše vycházet horká pára. Dbejte na opatrnost a při otevírání koše udržujte obličej, paže a ruce v dostatečné vzdálenosti od páry.

Použití – horní a spodní koš

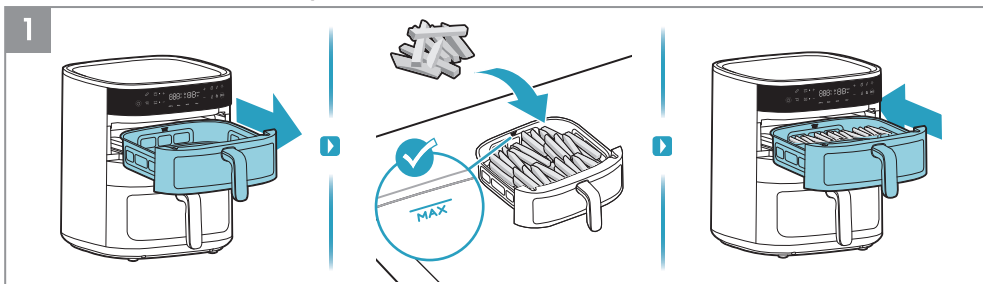

1. Nejprve vyjměte horní koš a vložte do něj potraviny, například hranolky.

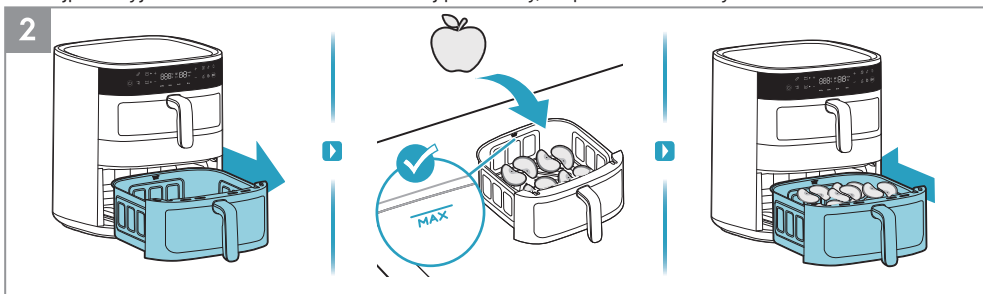

2. Poté vyjměte spodní koš a vložte do něj potraviny, například plátky jablka.



3. Stiskněte tlačítko ZAP/VYP. Nejprve vyberte horní koš. Poté vyberte požadovaný způsob vaření, například funkci Horkovzdušné fritování. Nastavte čas a teplotu tak, jak potřebujete, nebo vyberte jeden z přednastavených receptů, například recept Zelenina. Nakonec stiskněte tlačítko Spustit/pozastavit.



4. Poté vyberte spodní koš. Následně vyberte požadovaný způsob vaření, například funkci Sušení. Nastavte čas a teplotu tak, jak potřebujete. Nakonec stiskněte tlačítko Spustit/pozastavit

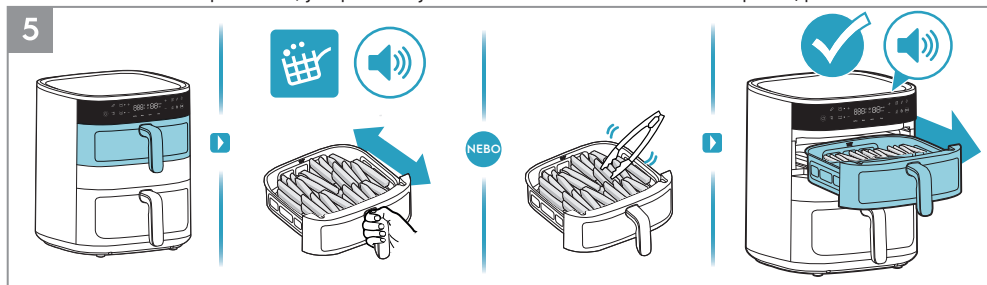

5. Až se během vaření rozsvítí ikona "Připomenutí promíchání" a ozve se zvukový signál, potraviny ve fritovacím koši jednou obraťte nebo opatrně lehce promíchejte pomocí náčiní odolného proti vysoké teplotě. Při uplynutí času vaření v horním koši spotřebič vydá zvukový signál.

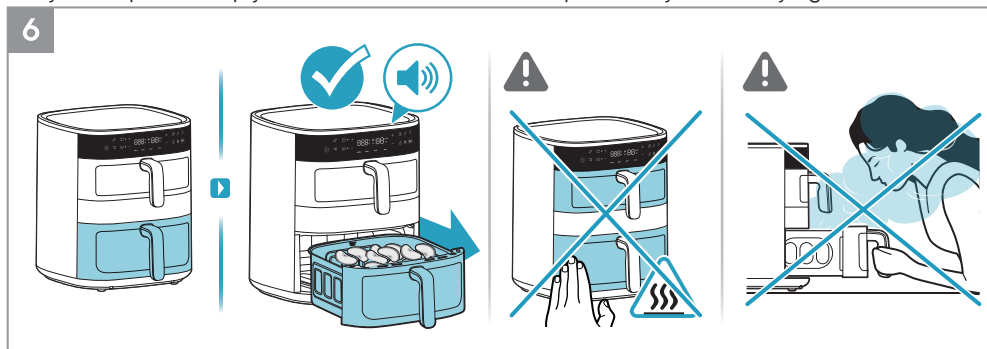

6. Při uplynutí času vaření ve spodním koši spotřebič vydá zvukový signál.

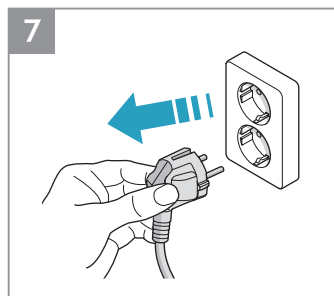

7. Po použití spotřebiče odpojte zástrčku jeho napájecího kabelu.

Použití – funkce Propojení

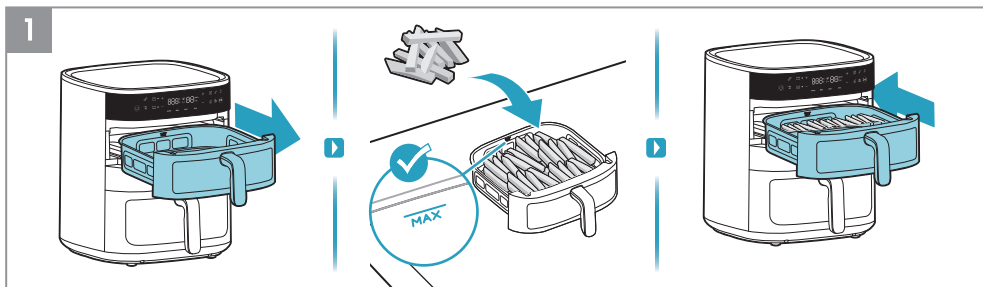

1. Nejprve vyjměte horní koš a vložte do něj potraviny, například hranolky.

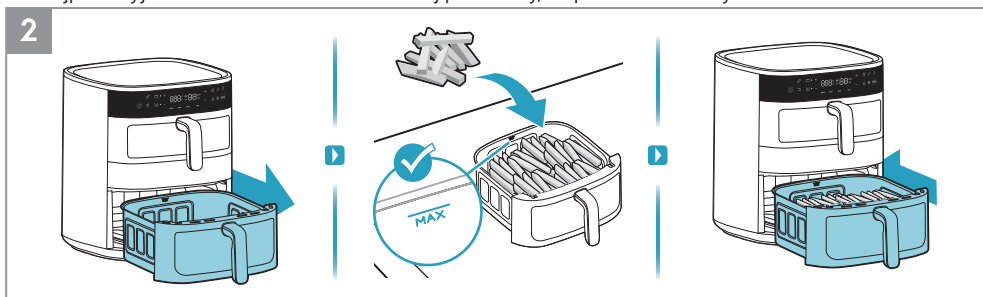

2. Poté vyjměte spodní koš a vložte do něj potraviny, například hranolky.



3. Stiskněte tlačítko ZAP/VYP. Nejprve vyberte funkci Propojení. Poté vyberte požadovaný způsob vaření, například funkci Horkovzdušné fritování. Nastavte čas a teplotu tak, jak potřebujete, nebo vyberte jeden z přednastavených receptů. Nakonec stiskněte tlačítko Spustit/pozastavit.

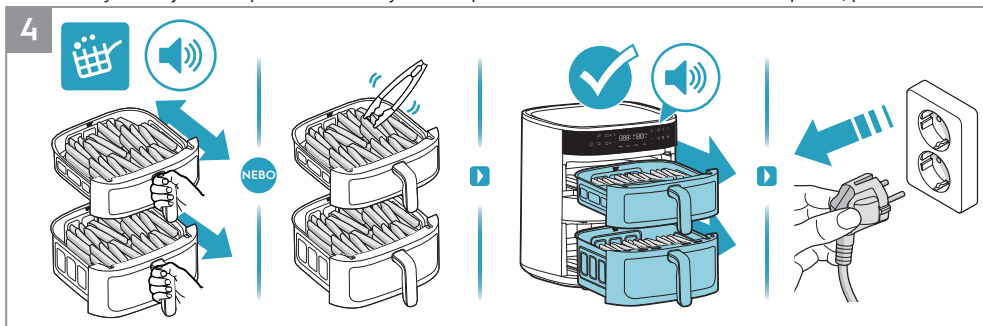

4. Až se během vaření rozsvítí ikona "Připomenutí promíchání" a ozve se zvukový signál, potraviny ve fritovacím koši jednou obraťte nebo opatrně lehce promíchejte pomocí náčiní odolného proti vysoké teplotě. Při uplynutí času vaření spotřebič vydá zvukový signál. Po použití spotřebiče odpojte zástrčku jeho napájecího kabelu.

Použití – funkce Synchronizace ukončení

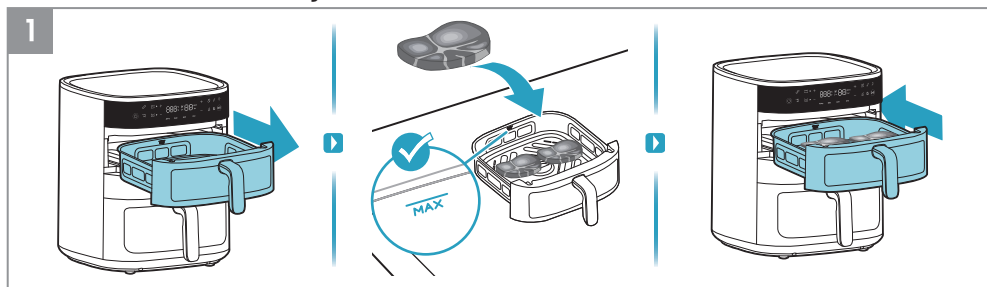

1. Nejprve vyjměte horní koš a vložte do něj potraviny, například steak.

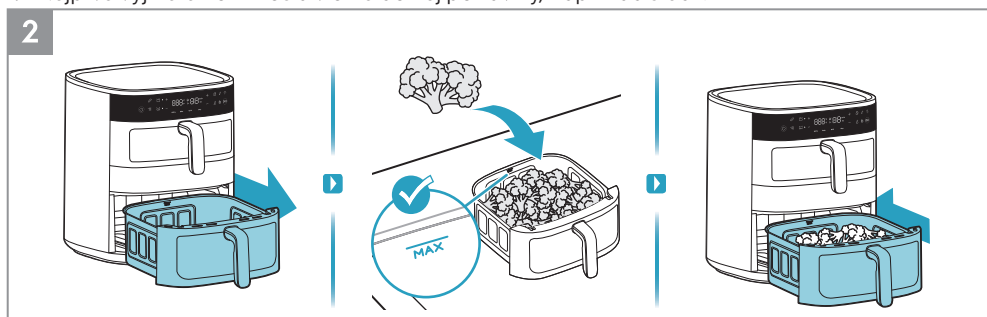

2. Poté vyjměte spodní koš a vložte do něj potraviny, například brokolici.



3. Stiskněte tlačítko ZAP/VYP. Vyberte funkci Synchronizace ukončení. Nejprve vyberte horní koš, poté požadovaný způsob vaření, například funkci Horkovzdušné fritování. Nastavte čas a teplotu tak, jak potřebujete, nebo vyberte jeden z přednastavených receptů, například Steak.



4. A poté vyberte spodní koš a požadovaný způsob vaření, například funkci Horkovzdušné fritování. Nastavte čas a teplotu tak, jak potřebujete, nebo vyberte jeden z přednastavených receptů. Nakonec stiskněte tlačítko Spustil/pozastavit.

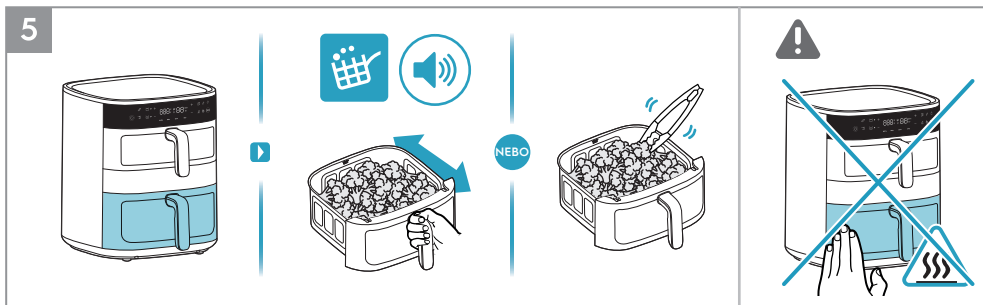

5. Nejprve se zahájí vaření ve spodním koši s delším nastaveným časem. Až se během vaření rozsvítí ikona "Připomenutí promíchání" a ozve se zvukový signál, potraviny ve fritovacím koši jednou obraťte nebo opatrně lehce promíchejte pomocí náčiní odolného proti vysoké teplotě.

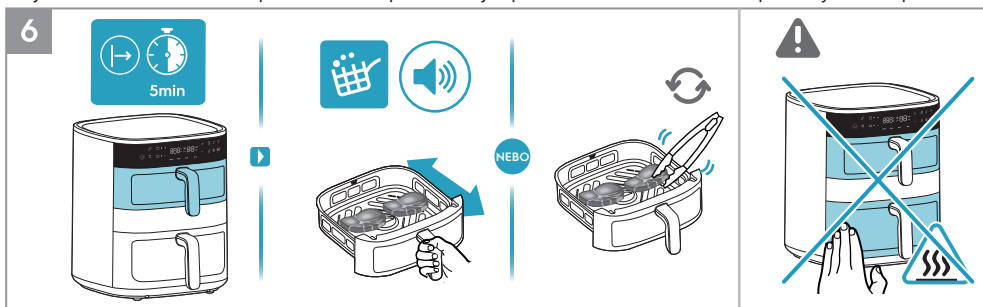

6. Poté se zahájí vaření v horním koši s kratším nastaveným časem. Až se během vaření rozsvítí ikona "Připomenutí promíchání" a ozve se zvukový signál, potraviny ve fritovacím koši jednou obraťte nebo opatrně lehce promíchejte pomocí náčiní odolného proti vysoké teplotě.

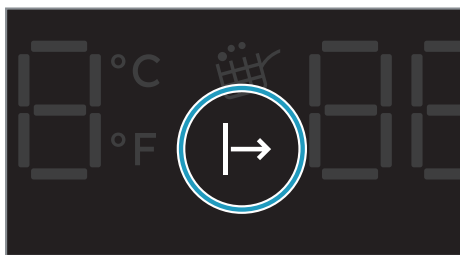

Kontrolka Čekání na vaření

V případě aktivace "funkce Synchronizace ukončení" se vaření v koši s kratším časem vaření zahájí o něco později než vaření v koši s delším časem vaření, takže vaření v obou koších skončí současně. Po dobu do zahájení vaření ve druhé koši bude svítit "kontrolka Čekání na vaření".

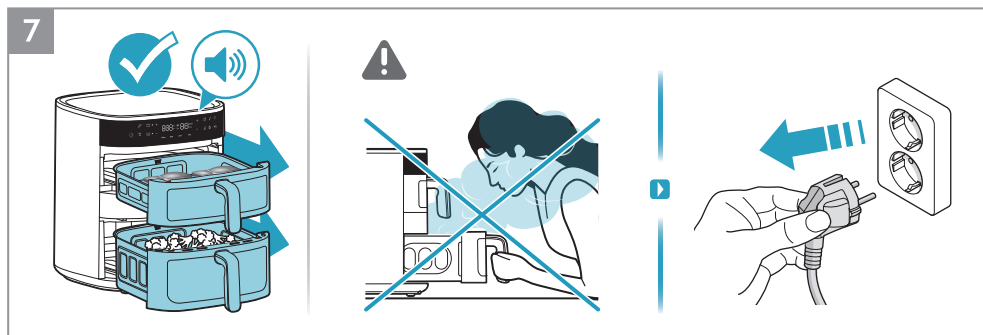

7. Při uplynutí času vaření spotřebič vydá zvukový signál. Po použití spotřebiče odpojte zástrčku jeho napájecího kabelu.

Čištění

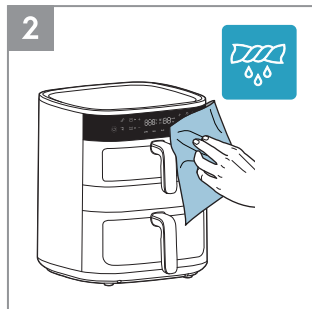
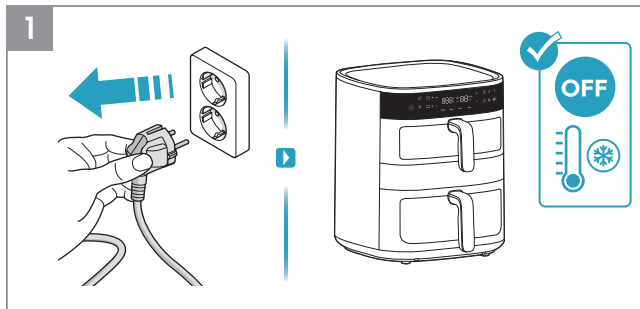

1. Před čištěním spotřebiče vždy odpojte zástrčku jeho napájecího kabelu a počkejte, dokud spotřebič nevychladne.
2. Otřete vnější povrch spotřebiče měkkou utěrkou.

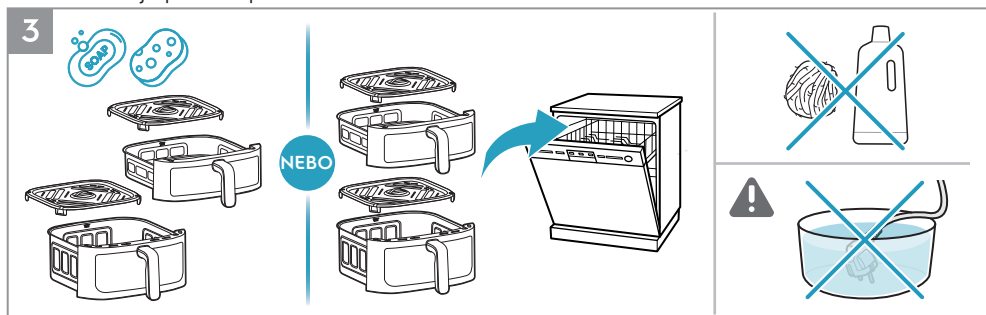

3. Omyjte koš a rošt teplou vodou a prostředkem na mytí nádobí, případně je vložte do myčky na nádobí.

⚠POZNÁMKA: Nepoužívejte abrazivní čisticí prostředky ani kovové náčiní, aby se nepoškodil nepřilnavý povrch.



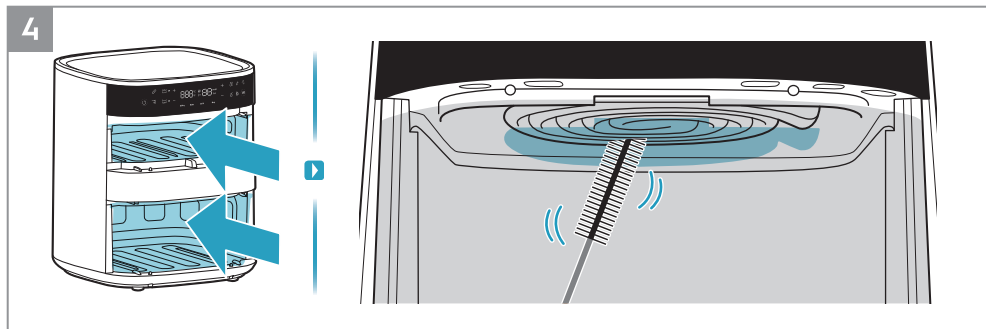









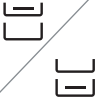

























UPOZORNĚNÍ: Nikdy neponořujte výrobek, jeho napájecí kabel nebo zástrčku do vody nebo jakékoli jiné kapaliny.



4. Očistěte topné těleso čisticím kartáčkem.



























POZNÁMKA: Před čištěním topného tělesa se ujistěte, že spotřebič zcela vychladl.

Pokyny pro vaření

							
AirFry	7mm/10mm 	 4l	400g	180°C	18min		
		 7l	400g	180°C	18min		
AirFry		 4l	400g	170°C	8min		
		 7l	400g	170°C	10min		
AirFry		 4l	400g/2 ks	140°C	15min		
		 7l	400g/2 ks	140°C	15min		
AirFry		 4l	1000g/8 ks	180°C	28min		
		 7l	1000g/8 ks	180°C	28min		
AirFry		 4l	400g/2 ks	200°C	10min		
		 7l	400g/2 ks	200°C	10min		
AirFry		 4l	220g/6cm	160°C	12min		
		 7l	220g/6cm	160°C	14min		

- EN
- BG
- CZ**
- DE
- DK
- EE
- FI
- FR
- GR
- HR
- HU
- IT
- LT
- LV
- NO
- NL
- PL
- PT
- RO
- RU
- SE
- SI
- SK
- SR
- TR
- UA
- ES
- GE
- AL

EN
BG
CZ
DE
DK
EE
FI
FR
GR
HR
HU
IT
LT
LV
NO
NL
PL
PT
RO
RU
SE
SI
SK
SR
TR
UA
ES
GE
AL

							
AirFry		 7l	1200g	180°C	55min		
AirFry		 7l	400g/9 ks	160°C	20min		
Grill		 4l	180g/4 ks	180°C	8min		
Grill		 7l	180g/4 ks	180°C	9min		
Dry		 4l	180g	80°C	3h		
Dry		 7l	180g	80°C	3h		
Dry		 4l	200g	80°C	3h		
Dry		 7l	200g	80°C	3h		

Co dělat, když...

Problém	Zkontrolujte, zda...
Spotřebič nelze aktivovat nebo uvést do chodu.	<ul style="list-style-type: none">• Spotřebič je správně připojen ke zdroji elektrické energie.• Koše jsou ve správné poloze. Ujistěte se, že jsou do spotřebiče zasunuty celé a umožňují tak napájení.• Je nastaven čas vaření.
Do spotřebiče nelze zasunout koš.	<ul style="list-style-type: none">• Koš není naplněn více než k označení jeho maximální kapacity.• Koš je správně umístěn. Po umístění koše do zařízení musí být slyšet cvaknutí.• Pod košem není předmět, který by bránil jeho řádnému zavření.
Ze spotřebiče vychází bílý kouř.	<ul style="list-style-type: none">• Potraviny, které připravujete, nejsou příliš mastné.• Koš, rošt a topné těleso jsou čisté.
Na displeji se zobrazuje kód E1.	<ul style="list-style-type: none">• Přerušený obvod horního koše.
Na displeji se zobrazuje kód E2.	<ul style="list-style-type: none">• Zkrat horního koše.
Na displeji se zobrazuje kód E3.	<ul style="list-style-type: none">• Přerušený obvod spodního koše.
Na displeji se zobrazuje kód E4.	<ul style="list-style-type: none">• Zkrat spodního koše.
Na displeji se zobrazuje kód E5.	<ul style="list-style-type: none">• Chyba komunikace PCBA ovládání.
Na displeji se zobrazuje kód E6.	<ul style="list-style-type: none">• Chyba komunikace PCBA napájení.

* V případě, že se na displeji zobrazí chybové kódy, musí spotřebič opravit servisní středisko.

Technické údaje

Výrobek	Horkovzdušná fritéza
Model	EAFD11B
Napětí (V~)	220-240 V
Příkon (W)	2700 W
Frekvence (Hz)	50 ~ 60 Hz
Kapacita	4 l + 7 l

EN

BG

CZ

DE

DK

EE

FI

FR

GR

HR

HU

IT

LT

LV

NO

NL

PL

PT

RO

RU

SE

SI

SK

SR

TR

UA

ES

GE

AL



Electrolux

Benutzerhandbuch

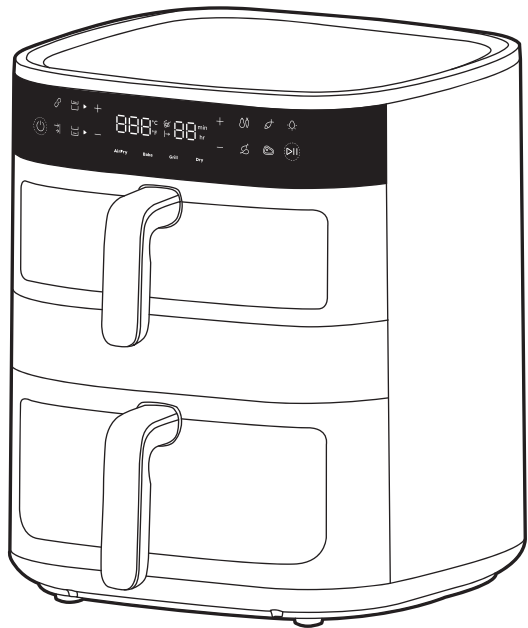

800 Heißluftfritteuse Dual

Allgemeine Übersicht

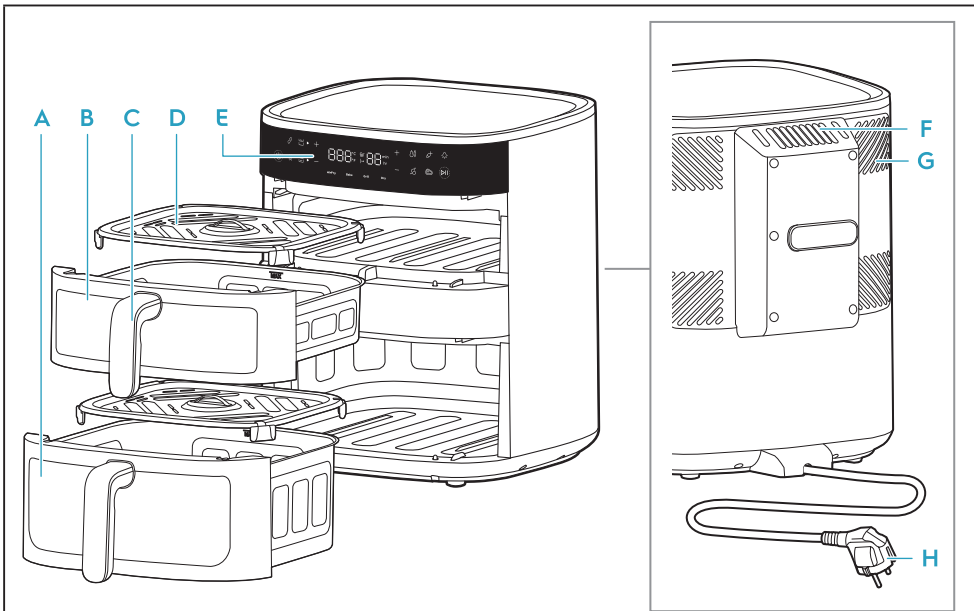

- | | | | |
|----------------------------|----------------------|----------------------|---------------------|
| A Unterer Korb (7L) | C Korbgriff | E Bedienfeld | G Kühlsystem |
| B Oberer Korb (4L) | D Rösteinsatz | F Luftauslass | H Hauptkabel |

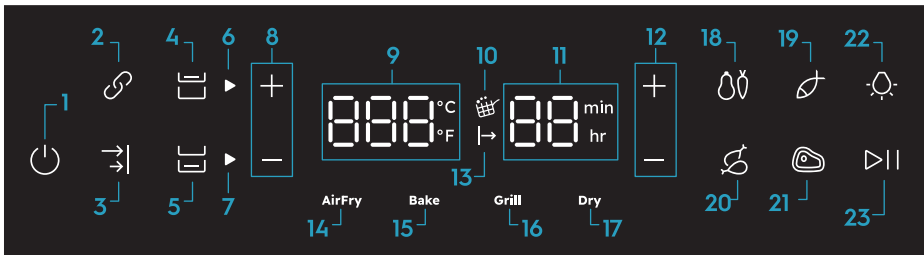

- | | | | |
|-----------------------------|---|---------------------------------|-----------------------------|
| 1. Ein/Aus | 8. Temperaturregelung | 12. Zeiteinstellung | 18. Gemüse |
| 2. Verbindungsfunktion | 9. Temperaturanzeige (40-200 °C) | 13. Warten auf das Garen | 19. Fisch |
| 3. Sync-End-Funktion | 10. Schüttel-/Wendeerinnerung | 14. Funktion Heißluftfrittieren | 20. Huhn |
| 4. Einstellung oberer Korb | 11. Zeitanzeige (Heißluftfrittieren: 1-99 min, Dörren: 1-5 h) | 15. Backfunktion | 21. Steak |
| 5. Einstellung unterer Korb | | 16. Grillfunktion | 22. Beleuchtungseinstellung |
| 6. Anzeige oberer Korb | | 17. Dörrfunktion | 23. Start/Pause |
| 7. Anzeige unterer Korb | | | |

Erste Inbetriebnahme

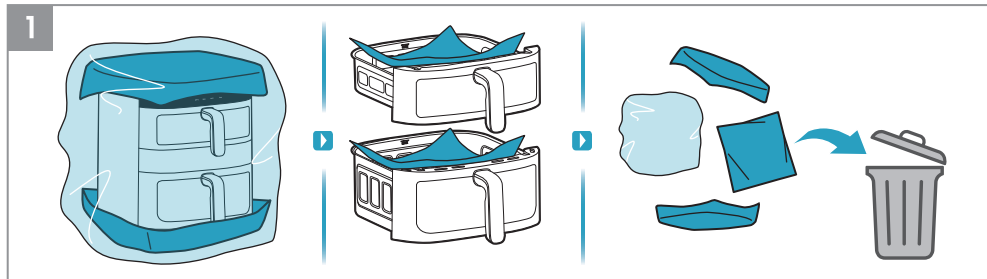

1. Entfernen Sie die Verpackung und die Schutzhülle.

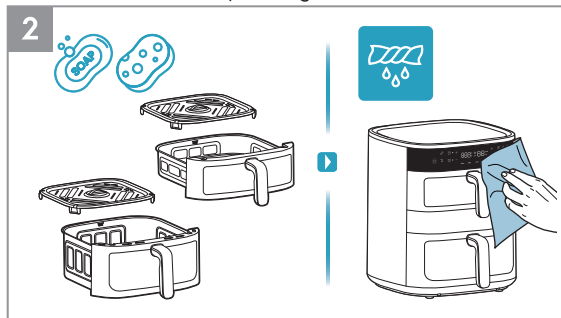

2. Reinigen Sie die Pfanne und den Rösteinsatz mit warmem Wasser und Geschirreiniger. Wischen Sie die Innen- und Außenseite des Geräts mit einem weichen Tuch ab.

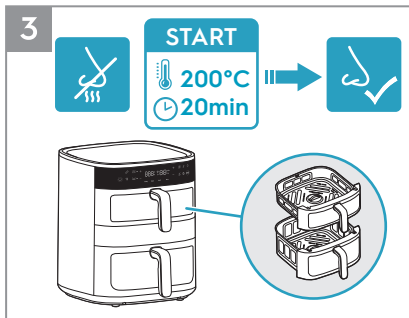

3. Es ist normal, dass ein neues Gerät beim ersten Betrieb riecht. Lassen Sie die leere Heißluftfritteuse vor dem ersten Betrieb bei 200 °C für 20 Minuten laufen, um das zu vermeiden.



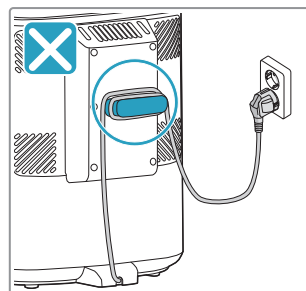
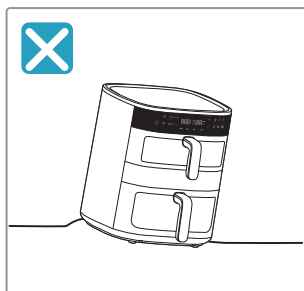
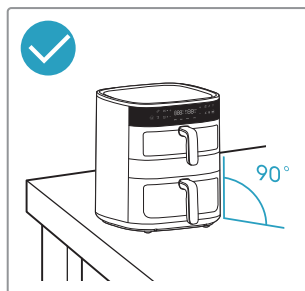
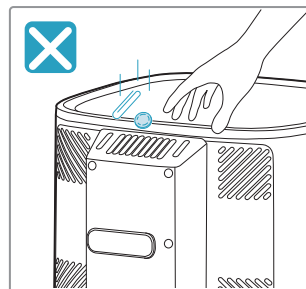
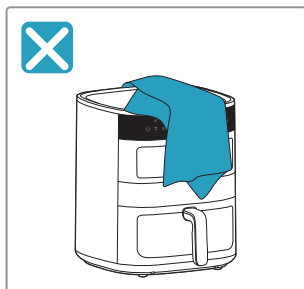
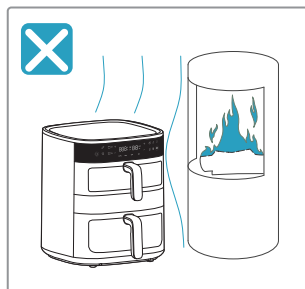



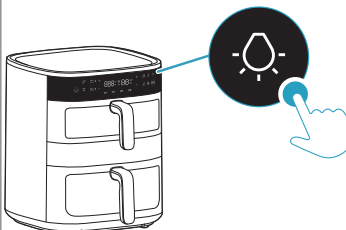
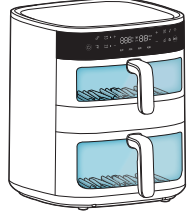

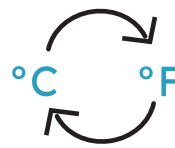

! Sicherheitsvorkehrungen



Beleuchtungseinstellung & Umrechnung der Temperatureinheit





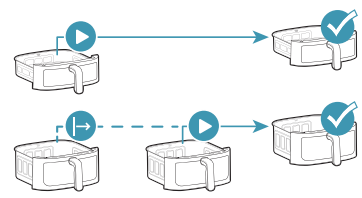





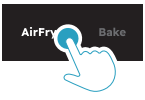



 <p>Beleuchtungseinstellung</p>		 <p>30 Sek.</p>
<p>°C/°F</p> <p>Umrechnung der Temperatureinheit</p>	 <p>30 Sek.</p>	

Korbauswahl

	 <p>4L</p>	 <p>7L</p>	
 <p>Oberer Korb</p>	<input checked="" type="checkbox"/>		
 <p>Unterer Korb</p>		<input checked="" type="checkbox"/>	
 <p>Verbindungsfunktion</p>	<input checked="" type="checkbox"/>	<input checked="" type="checkbox"/>	
 <p>Sync-End-Funktion</p>	<input checked="" type="checkbox"/>	<input checked="" type="checkbox"/>	

- EN
- BG
- CZ
- DE**
- DK
- EE
- FI
- FR
- GR
- HR
- HU
- IT
- LT
- LV
- NO
- NL
- PL
- PT
- RO
- RU
- SE
- SI
- SK
- SR
- TR
- UA
- ES
- GE
- AL

Voreingestellte Funktionen

					
AirFry	180°C	15min	60-200°C	1-99min	
	170°C	10min	60-200°C	1-99min	
	140°C	15min	60-200°C	1-99min	
	180°C	30min	60-200°C	1-99min	
	200°C	10min	60-200°C	1-99min	
Bake	170°C	15min	60-200°C	1-99min	
Grill	200°C	5min	60-200°C	1-99min	
Dry	80°C	5h	40-80°C	1-5h	

Vor dem Garen

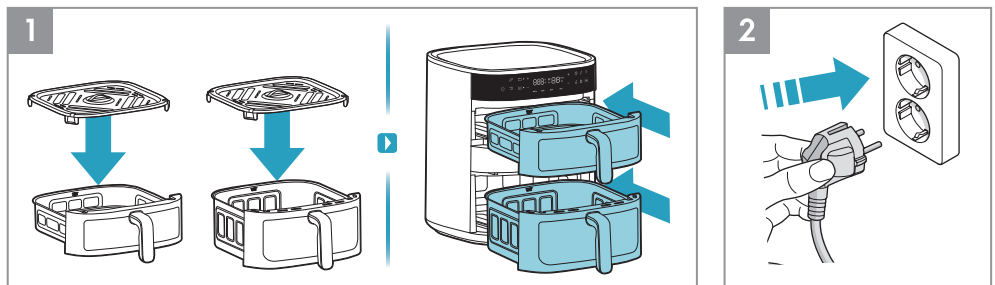

1. Setzen Sie vor jedem Garen den Röstesatz in den Korb ein (das hitzebeständige Silikon-Pad des Röstesatzes muss nicht entfernt werden) und schieben Sie den Korb vollständig in das Gerät ein.
2. Stecken Sie den Netzstecker in die Steckdose.

Verwendung - Einzelkorb

- EN
- BG
- CZ
- DE
- DK
- EE
- FI
- FR
- GR
- HR
- HU
- IT
- LT
- LV
- NO
- NL
- PL
- PT
- RO
- RU
- SE
- SI
- SK
- SR
- TR
- UA
- ES
- GE
- AL

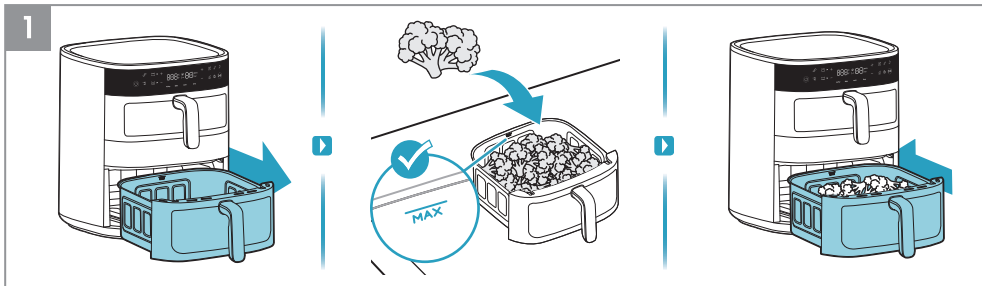

1. Ziehen Sie einen Korb heraus und stellen Sie ihn auf eine stabile Oberfläche. Geben Sie das Gargut in den Korb und beachten Sie dabei die Kapazitätsanzeige "MAX.". Schieben Sie den Korb dann vollständig in das Gerät ein.

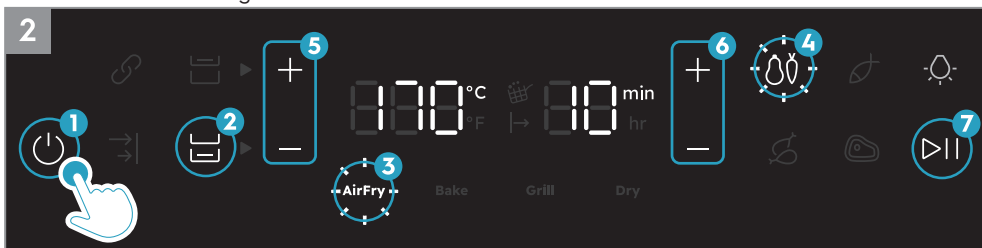

2. Drücken Sie die Ein-/Aus-Taste. Zuerst wählen Sie den Korb mit dem Gargut aus. Dann wählen Sie Ihre gewünschte Garmethode aus, zum Beispiel die Funktion Heißluftfrittieren. Stellen Sie die Zeit und die Temperatur nach Bedarf ein oder wählen Sie eines der voreingestellten Rezepte aus, zum Beispiel "Gemüse". Zum Schluss drücken Sie die Start-/Pause-Taste.

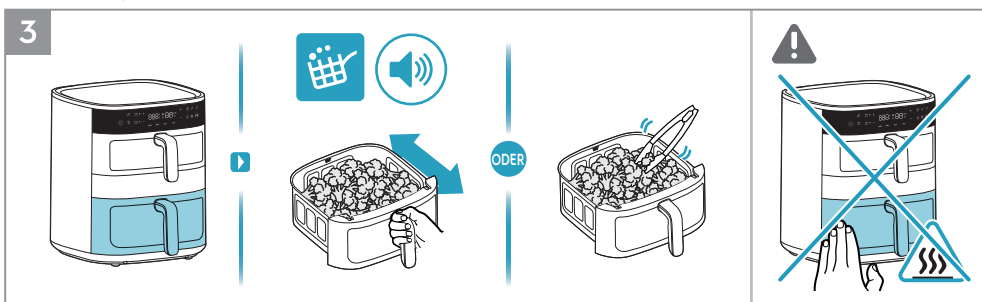

3. Wenn während des Garvorgangs das Symbol "Schüttel-/Wendeerinnerung" aufleuchtet und ein Signalton ertönt, wenden Sie die Speisen mit hitzebeständigen Utensilien einmal oder schütteln Sie den Frittierkorb vorsichtig.

- ⚠ **VORSICHT:** Schütteln Sie den Frittierkorb nicht zu sehr, um Spritzer und Verbrennungen zu vermeiden.
- ⚠ **VORSICHT:** Vorsicht vor heißen Oberflächen, wenn das Gerät in Betrieb ist.

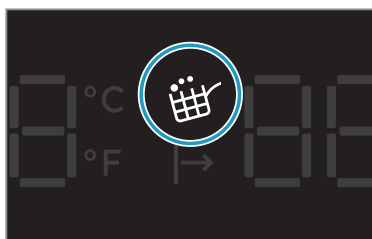

Schüttel-/Wendeerinnerung

Die "Schüttel-/Wendeerinnerung" ist während der Funktion Heißluftfrittieren und den voreingestellten Rezepten wie Gemüse, Fisch, Hähnchen und Steak aktiviert. Wenn es Zeit ist, Ihre Speisen zu schütteln oder zu wenden, leuchtet das Symbol "Schüttel-/Wendeerinnerung" auf und blinkt eine Minute lang, während dreimal ein Piepton ertönt. Die "Schüttel-/Wendeerinnerung" ist nicht unbedingt erforderlich, daher wird der Garvorgang wie gewohnt fortgesetzt, auch wenn das Gargut nicht gewendet oder geschüttelt wird.



4. Am Ende der Garzeit gibt das Gerät einen Signalton ab. Entnehmen Sie den Korb vorsichtig und stellen Sie ihn auf eine hitzebeständige Oberfläche. Nehmen Sie das Gerät nach der Verwendung vom Strom.

⚠ **VORSICHT:** Beim Öffnen des Korbs während oder nach dem Garvorgang kann heißer Dampf austreten. Achten Sie darauf, dass Ihr Gesicht, Ihre Arme und Hände beim Öffnen nicht in die Nähe des Dampfes kommen.

Verwendung – Oberer + unterer Korb

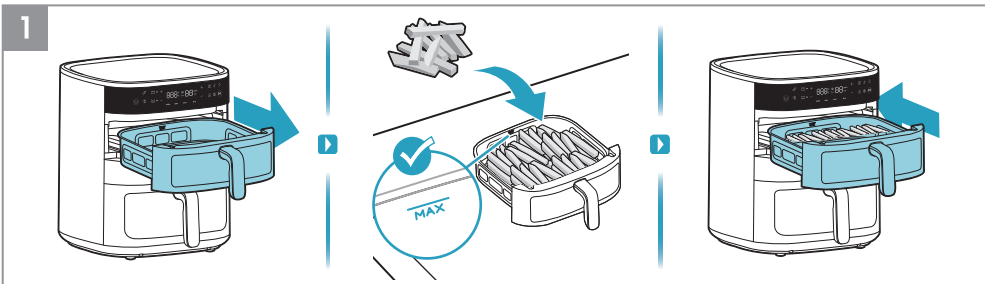

1. Zuerst ziehen Sie den oberen Korb heraus und legen das Gargut in den Korb, zum Beispiel Pommes frites.

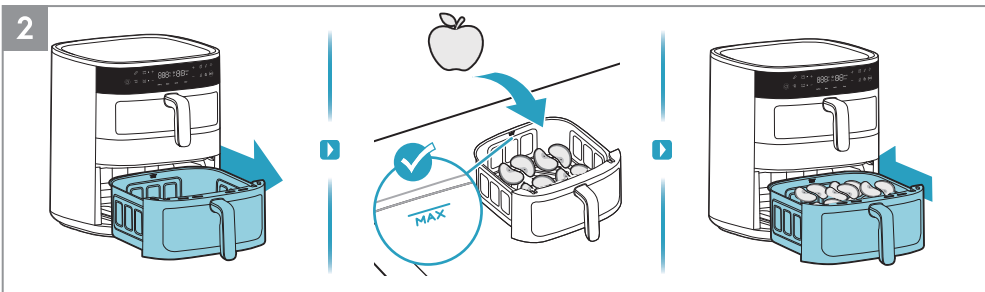

2. Ziehen Sie als Zweites den unteren Korb heraus und legen Sie weiteres Gargut hinein, zum Beispiel Apfelscheiben.



3. Drücken Sie die Ein-/Aus-Taste. Wählen Sie zuerst den oberen Korb aus. Dann wählen Sie Ihre gewünschte Garmethode aus, zum Beispiel die Funktion Heißluftfrittieren. Stellen Sie die Zeit und die Temperatur nach Bedarf ein oder wählen Sie eines der voreingestellten Rezepte aus, zum Beispiel "Gemüse". Zum Schluss drücken Sie die Start-/Pause-Taste.

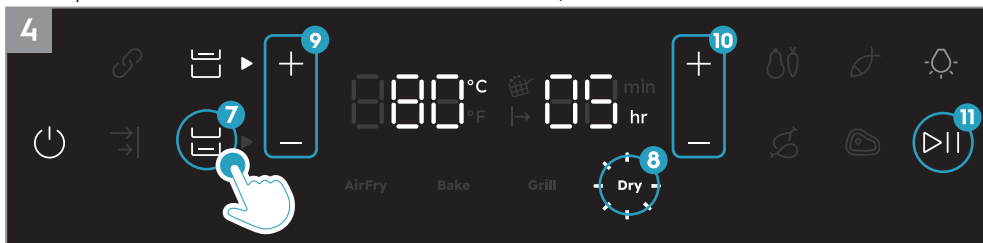

4. Als Zweites wählen Sie den unteren Korb. Wählen Sie dann Ihre gewünschte Garmethode, zum Beispiel die Dörrfunktion. Stellen Sie die Zeit und die Temperatur nach Bedarf ein. Zum Schluss drücken Sie die Start-/Pause-Taste.

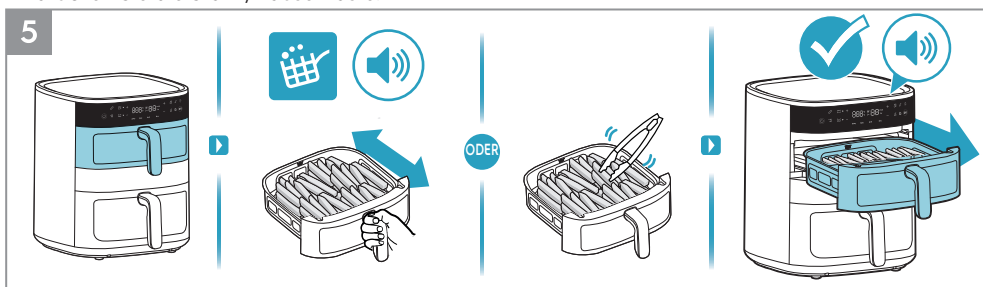

5. Wenn während des Garvorgangs das Symbol "Schüttel-/Wendeerinnerung" aufleuchtet und ein Signalton ertönt, wenden Sie die Speisen mit hitzebeständigen Utensilien einmal oder schüttern Sie den Frittierkorb vorsichtig. Am Ende der Garzeit des oberen Korbs gibt das Gerät einen Signalton ab.

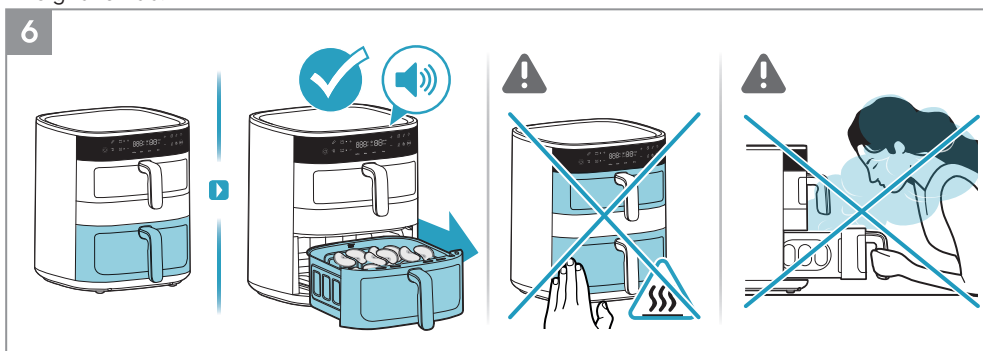

6. Am Ende der Garzeit des unteren Korbs gibt das Gerät einen Signalton ab.

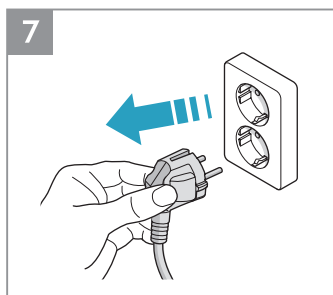

7. Nehmen Sie das Gerät nach der Verwendung vom Strom.

Verwendung - Verbindungsfunktion

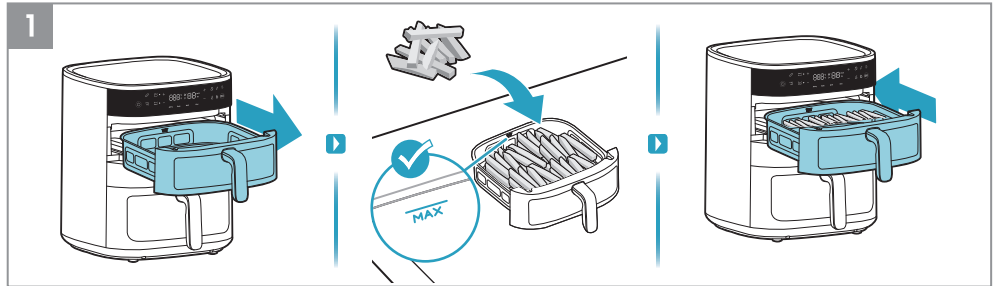

1. Zuerst ziehen Sie den oberen Korb heraus und legen das Gargut in den Korb, zum Beispiel Pommes frites.

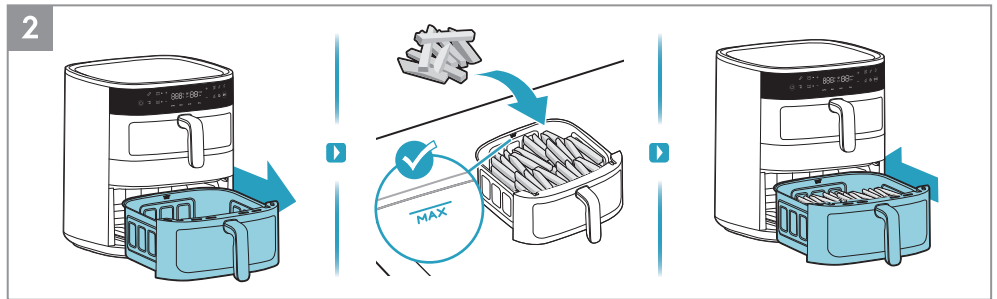

2. Als Zweites ziehen Sie den unteren Korb heraus und legen Sie weiteres Gargut in den Korb, zum Beispiel Pommes frites.



3. Drücken Sie die Ein-/Aus-Taste. Zuerst wählen Sie die Verbindungsfunktion. Dann wählen Sie Ihre gewünschte Garmethode aus, zum Beispiel die Funktion Heißluftfrittieren. Stellen Sie die Zeit und die Temperatur nach Bedarf ein oder wählen Sie eines der voreingestellten Rezepte aus. Zum Schluss drücken Sie die Start-/Pause-Taste.

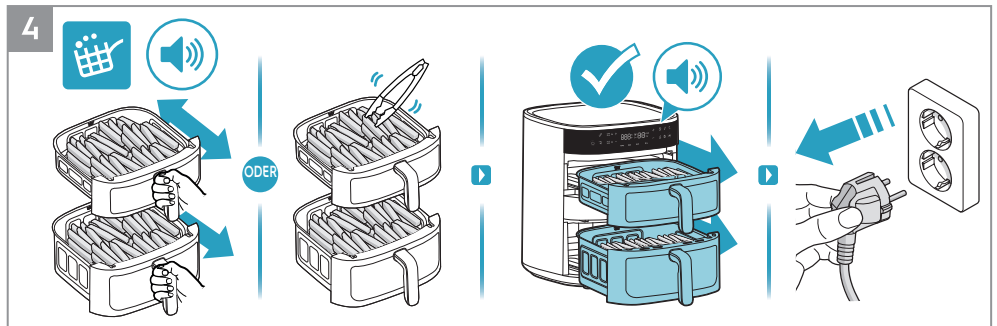

4. Wenn während des Garvorgangs das Symbol "Schüttel-/Wendeerinnerung" aufleuchtet und ein Signalton ertönt, wenden Sie die Speisen mit hitzebeständigen Utensilien einmal oder schütteln Sie den Frittierkorb vorsichtig. Am Ende der Garzeit gibt das Gerät einen Signalton ab. Nehmen Sie das Gerät nach der Verwendung vom Strom.

Verwendung - Sync-End-Funktion

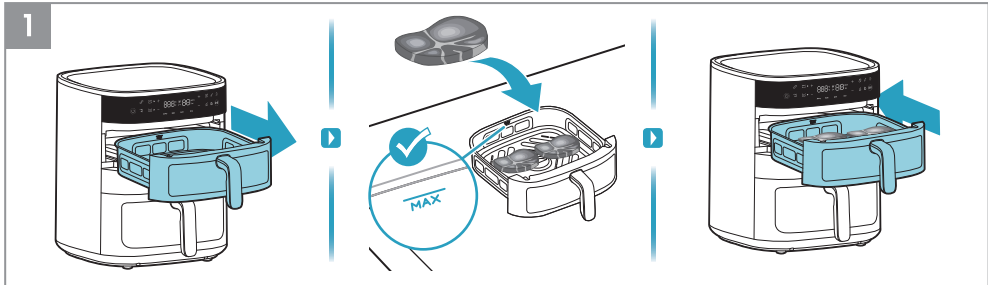

1. Zuerst ziehen Sie den oberen Korb heraus und legen das Gargut in den Korb, zum Beispiel Steak.

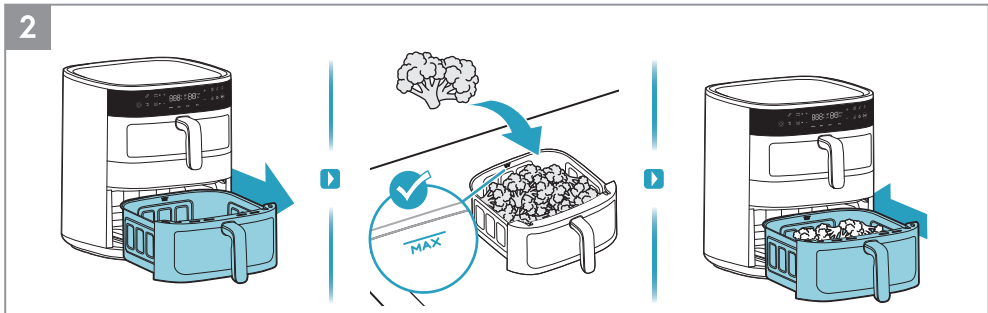

2. Als Zweites ziehen Sie den unteren Korb heraus und legen Sie weiteres Gargut in den Korb, zum Beispiel Brokkoli.



3. Drücken Sie die Ein-/Aus-Taste. Drücken Sie die Sync-End-Funktion. Wählen Sie zuerst den oberen Korb und dann die gewünschte Garmethode, zum Beispiel die Funktion Heißblutfrittieren. Stellen Sie die Zeit und die Temperatur nach Bedarf ein oder wählen Sie eines der voreingestellten Rezepte aus, zum Beispiel "Steak".

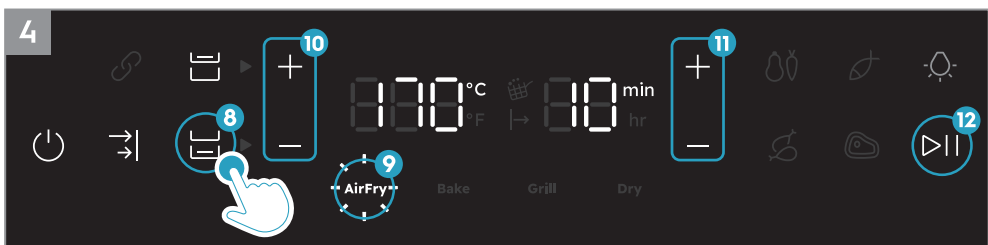

4. Wählen Sie dann den unteren Korb aus und wählen Sie die gewünschte Garmethode, zum Beispiel die Funktion Heißblutfrittieren. Stellen Sie die Zeit und die Temperatur nach Bedarf ein oder wählen Sie eines der voreingestellten Rezepte aus. Zum Schluss drücken Sie die Start-/Pause-Taste.

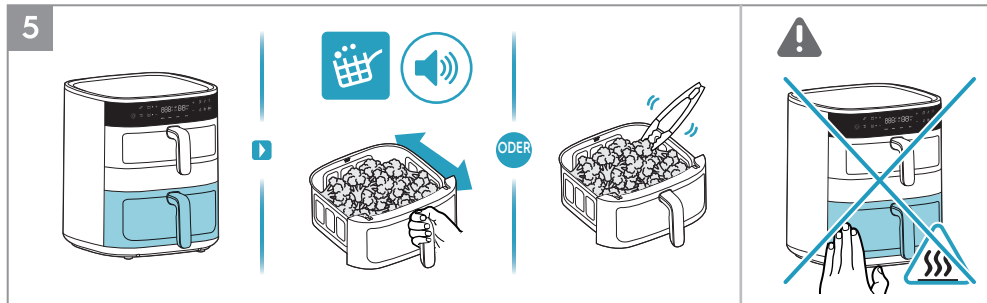

5. Zunächst wird der untere Korb mit längerer Einstellzeit für das Garen priorisiert. Wenn während des Garvorgangs das Symbol „Schüttel-/Wendeerinnerung“ aufleuchtet und ein Signalton ertönt, wenden Sie die Speisen mit hitzebeständigen Utensilien einmal oder schütteln Sie den Frittierkorb vorsichtig.

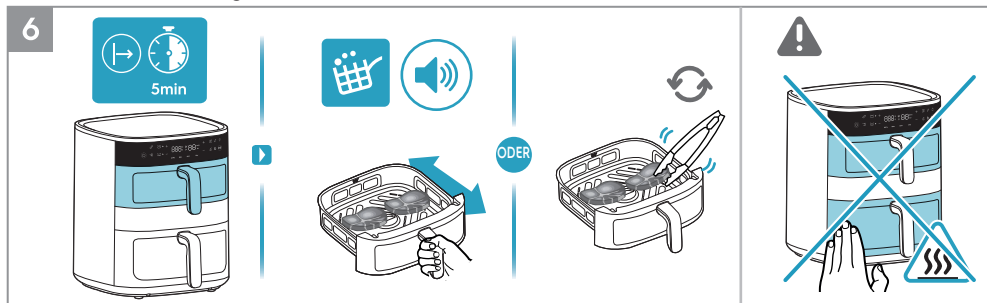

6. Als Zweites beginnt der obere Korb mit kürzerer Einstellzeit mit dem Garen. Wenn während des Garvorgangs das Symbol „Schüttel-/Wendeerinnerung“ aufleuchtet und ein Signalton ertönt, wenden Sie die Speisen mit hitzebeständigen Utensilien einmal oder schütteln Sie den Frittierkorb vorsichtig.

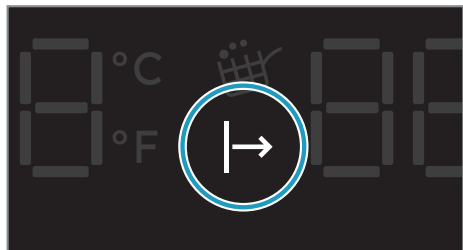

Anzeige "Warten auf das Garen"

Wenn die "Sync-End-Funktion" aktiviert ist, wartet der Korb mit der kürzeren Garzeit mit dem Garvorgang, bis der Korb mit der längeren Garzeit eine Weile gegart hat, sodass beide Körbe gleichzeitig mit dem Garvorgang fertig werden. Während dieser Zeit leuchtet die Anzeige "Warten auf das Garen" auf, bis der Garvorgang beginnt.

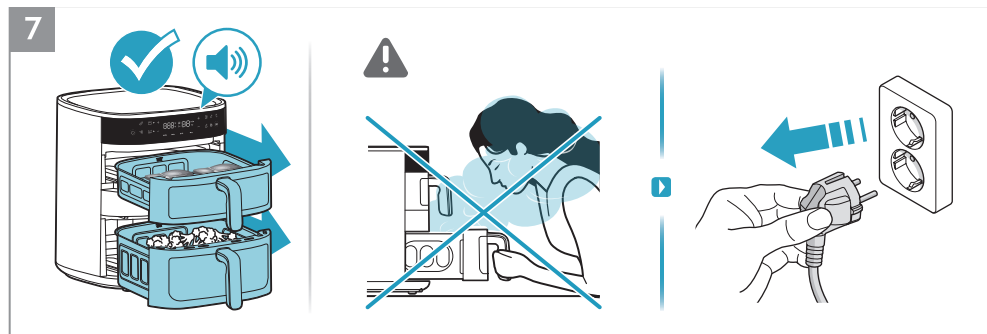

7. Am Ende der Garzeit gibt das Gerät einen Signalton ab. Nehmen Sie das Gerät nach der Verwendung vom Strom.

Reinigung

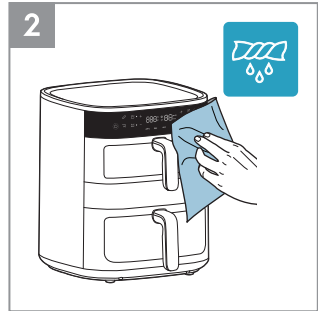
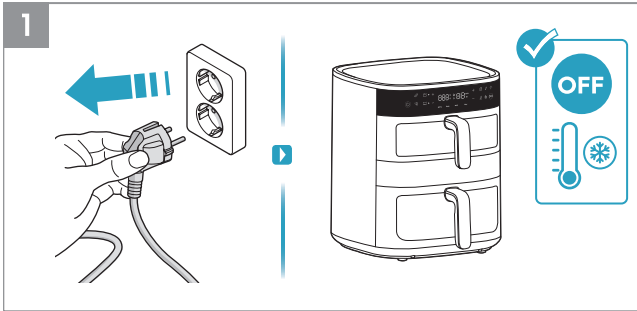

1. Ziehen Sie stets den Netzstecker und warten Sie, bis das Gerät abgekühlt ist, bevor Sie es reinigen.
2. Wischen Sie die Außenseite des Geräts mit einem weichen Tuch ab.

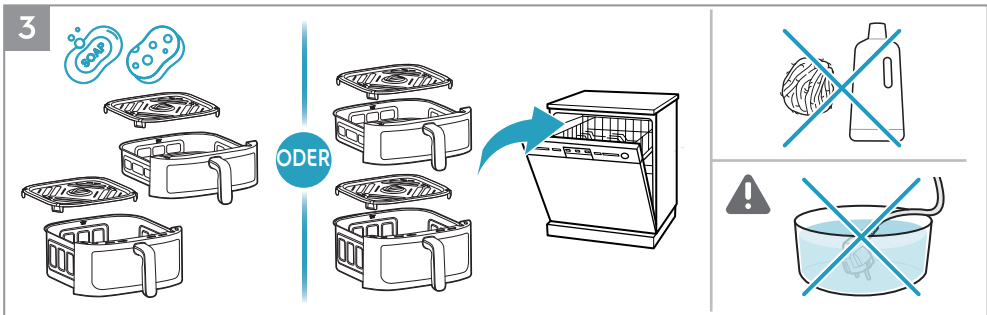

3. Reinigen Sie die Pfanne und den Röststeinsatz mit warmem Wasser und Geschirreiniger oder geben Sie sie in die Spülmaschine.

⚠HINWEIS: Verwenden Sie keine scheuernden Reinigungsmittel oder Metallwerkzeuge, um die Antihafbeschichtung zu schützen.

VORSICHT: Tauchen Sie das Produkt, das Kabel oder den Stecker niemals in Wasser oder andere Flüssigkeiten ein.

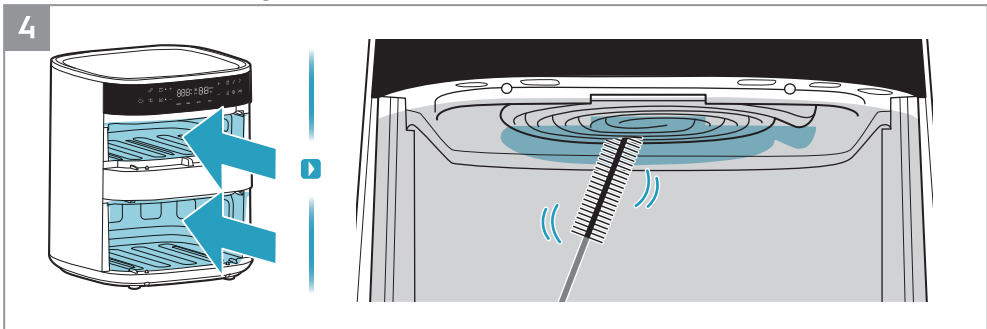











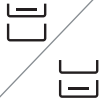







































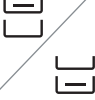













4. Reinigen Sie das Heizelement mit einer Reinigungsbürste.

HINWEIS: Stellen Sie sicher, dass das Gerät vollständig abgekühlt ist, bevor Sie das Heizelement reinigen.

EN
BG
CZ
DE
DK
EE
FI
FR
GR
HR
HU
IT
LT
LV
NO
NL
PL
PT
RO
RU
SE
SI
SK
SR
TR
UA
ES
GE
AL

Garanleitung

								
AirFry	7mm/10mm 	4L 	400g	180°C	18min			
		7L 	400g	180°C	18min			
AirFry		4L 	400g	170°C	8min			
		7L 	400g	170°C	10min			
AirFry		4L 	400g/2Stk.	140°C	15min			
		7L 	400g/2Stk.	140°C	15min			
AirFry		4L 	1000g/8Stk.	180°C	28min			
		7L 	1000g/8Stk.	180°C	28min			
AirFry		4L 	400g/2Stk.	200°C	10min			
		7L 	400g/2Stk.	200°C	10min			
AirFry		4L 	220g/6cm	160°C	12min			
		7L 	220g/6cm	160°C	14min			

							
AirFry		 7L	1200g	180°C	55min		
AirFry		 7L	400g/9Stk.	160°C	20min		
Grill		 4L	180g/4Stk.	180°C	8min		
Grill		 7L	180g/4Stk.	180°C	9min		
Dry		 4L	180g	80°C	3h		
Dry		 7L	180g	80°C	3h		
Dry		 4L	200g	80°C	3h		
Dry		 7L	200g	80°C	3h		

- EN
- BG
- CZ
- DE**
- DK
- EE
- FI
- FR
- GR
- HR
- HU
- IT
- LT
- LV
- NO
- NL
- PL
- PT
- RO
- RU
- SE
- SI
- SK
- SR
- TR
- UA
- ES
- GE
- AL

Was tun, wenn...

Problem	Überprüfen Sie, ob...
Sie können das Gerät nicht starten oder bedienen.	<ul style="list-style-type: none"> • Das Gerät ist korrekt an die Stromversorgung angeschlossen. • Die Körbe sind in der richtigen Position. Stellen Sie sicher, dass sie vollständig in das Gerät eingeschoben sind, um die Stromversorgung zu aktivieren. • Die Garzeit ist eingestellt
Sie können den Korb nicht in das Gerät hineinschieben.	<ul style="list-style-type: none"> • Der Korb ist über seine maximale Kapazität hinaus gefüllt • Der Korb ist richtig hineingeschoben. Er muss einrasten, wenn Sie ihn in das Gerät einschieben. • Unter dem Korb befindet sich ein Gegenstand, der das vollständige Schließen verhindert
Weißer Rauch kommt aus dem Gerät.	<ul style="list-style-type: none"> • Das Gargut, das Sie zubereiten, ist zu fettig. • Der Korb, der Röstesatz und das Heizelement sind sauber.
Das Display zeigt "E1" an.	• Unterbrochener Stromkreis oberer Korb.
Das Display zeigt "E2" an.	• Kurzschluss oberer Korb.
Das Display zeigt "E3" an.	• Unterbrochener Stromkreis unterer Korb.
Das Display zeigt "E4" an.	• Kurzschluss unterer Korb.
Das Display zeigt "E5" an.	• Kommunikationsfehler der Steuerungs-PCBA.
Das Display zeigt "E6" an.	• Kommunikationsfehler der Power-PCBA.

* Wenn auf dem Display Fehlercodes angezeigt werden, muss das Gerät von einem Servicecenter repariert werden.

Technische Daten

Produkt	Heißluftfritteuse
Modell	EAFD11B
Volt (V)	220 V - 240 V
Leistung (W)	2700 W
Frequenz (Hz)	50 - 60 Hz
Kapazität	4 L + 7 L



Instruktionsbog

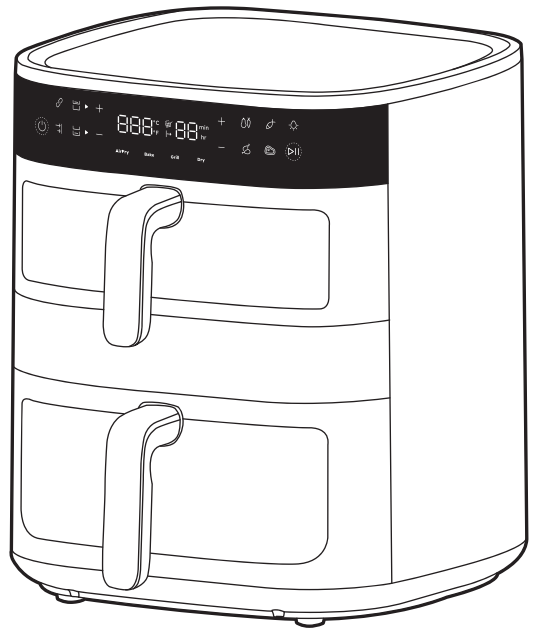

800 Air Fryer Dual

Generelt oversigt

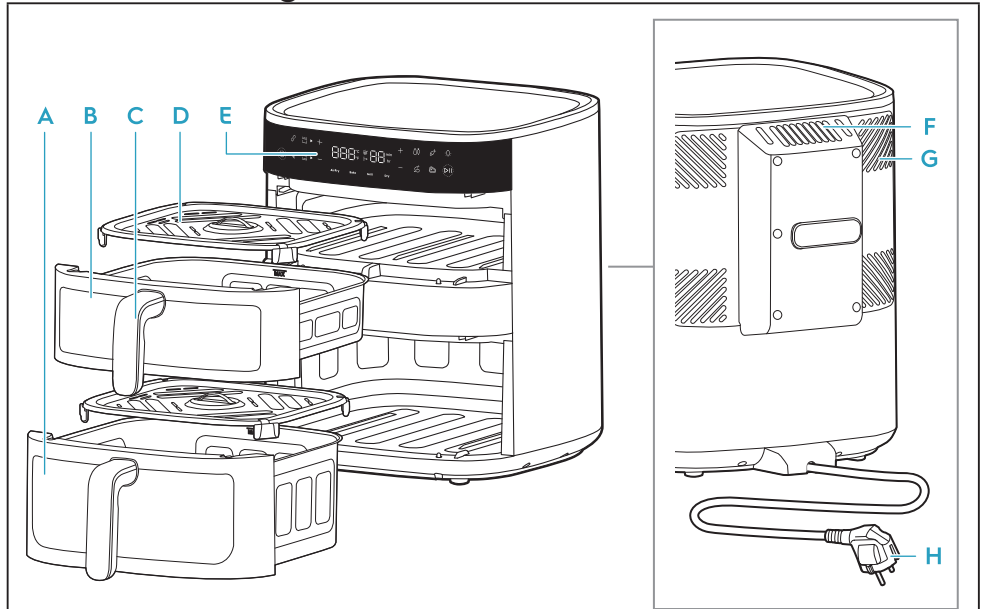

- | | | | |
|------------------------------|---------------------------|-----------------------|-----------------------|
| A Nederste kurv (7 L) | C Håndtag til kurv | E Kontrolpanel | G Kølesystem |
| B Øverste kurv (4L) | D Gitter | F Luftudtag | H Hovedledning |

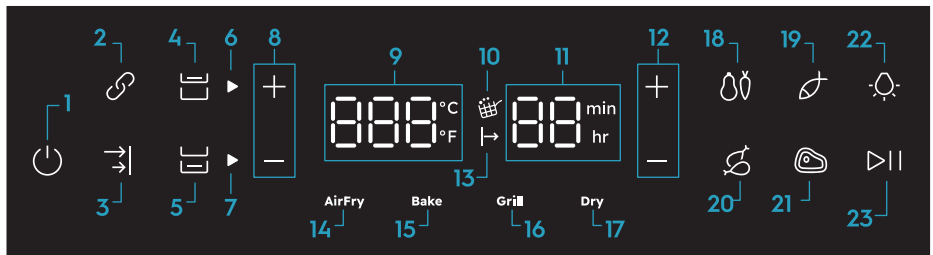

- | | | | |
|-------------------------------|--|---------------------------|-----------------------|
| 1. Tænd/sluk | 8. Temperaturstyring | 13. Venter på at lave mad | 20. Kylling |
| 2. Link-funktion | 9. Temperaturindikator (40-200°C) | 14. AirFry-funktion | 21. Bøf |
| 3. Synchroniser slut-funktion | 10. Påmindelse om at ryste | 15. Bagefunktion | 22. Belysningsstyring |
| 4. Styring af øverste kurv | 11. Tidsindikator (AirFry: 1-99 min., Dehydrering: 1- 5 t) | 16. Grill-funktion | 23. Afspil/Pause |
| 5. Styring af nederste kurv | 12. Tidsstyring | 17. Tørringsfunktion | |
| 6. Indikator for øverste kurv | | 18. Grøntsager | |
| 7. Indikator nederste kurv | | 19. Fisk | |

Før første brug

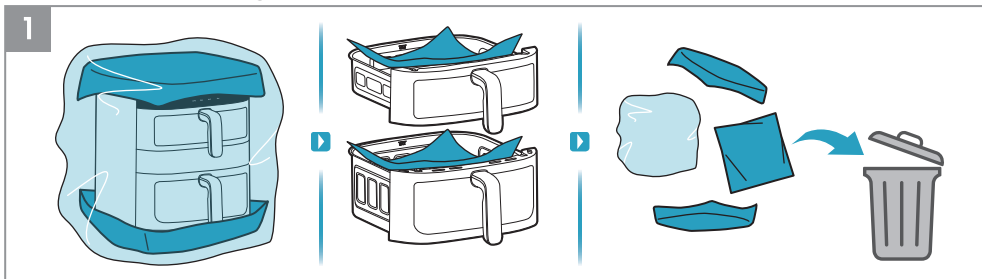

1. Fjern al emballage og beskyttelsesmateriale.

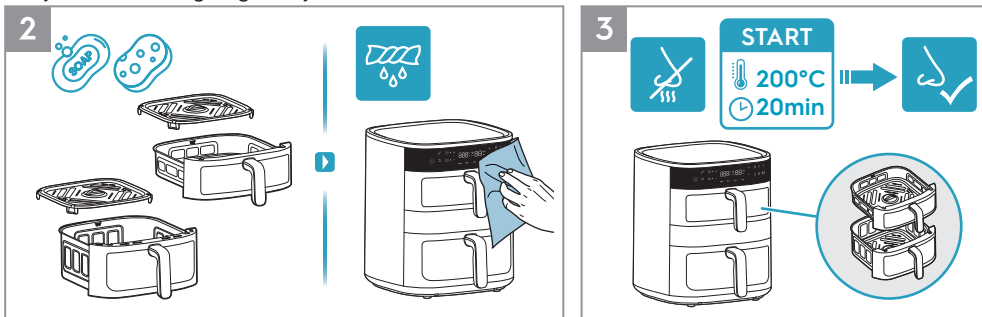

2. Rengør pande og rist med varmt vand og opvaskemiddel. Tør apparatet af indvendigt og udvendigt med en blød klud.

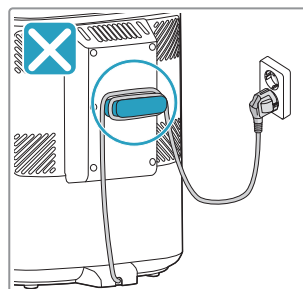
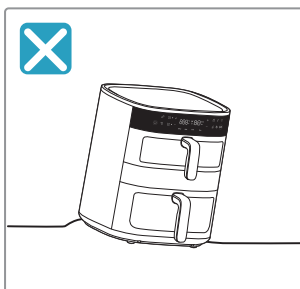
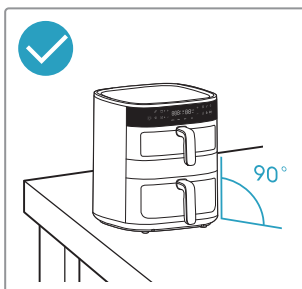
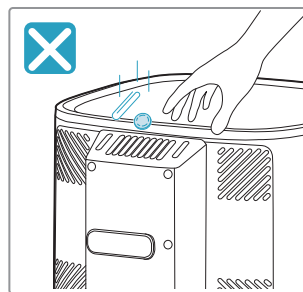
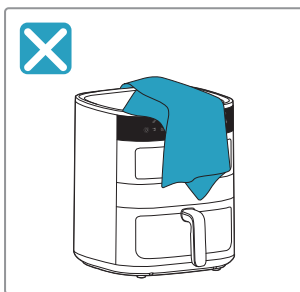

3. Det er normalt, at en ny enhed afgiver lugt de første gange, den anvendes. Kør den tomme airfryer ved 200 °C i 20 minutter før første brug for at undgå dette.

! Sikkerhedsforanstaltninger





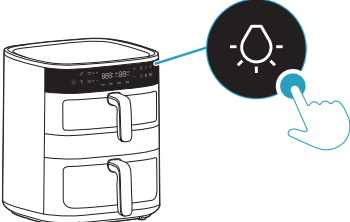
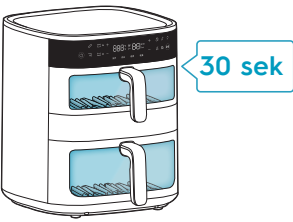

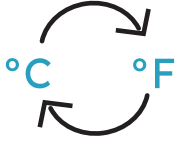



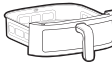



EN
BG
CZ
DE
DK
EE
FI
FR
GR
HR
HU
IT
LT
LV
NO
NL
PL
PT
RO
RU
SE
SI
SK
SR
TR
UA
ES
GE
AL







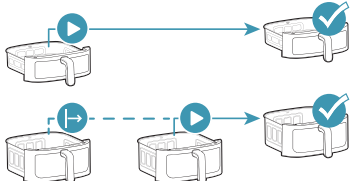







Belysningsstyring og konvertering af temperaturskala

 <p>Belysningsstyring</p>		
<p>°C/°F</p> <p>Konvertering af temperaturskala</p>		

Valg af kurv

	 <p>4L</p>	 <p>7L</p>	
 <p>Øverste kurv</p>			
 <p>Nederste kurv</p>			
 <p>Link-funktion</p>			
 <p>Synkroniser slut-funktion</p>			

Forudindstillingsfunktioner

 AirFry					
AirFry	180°C	15min	60-200°C	1-99min	
	170°C	10min	60-200°C	1-99min	
	140°C	15min	60-200°C	1-99min	
	180°C	30min	60-200°C	1-99min	
	200°C	10min	60-200°C	1-99min	
Bake	170°C	15min	60-200°C	1-99min	
Grill	200°C	5min	60-200°C	1-99min	
Dry	80°C	5 timer	40-80°C	1-5timer	

Før tilberedning

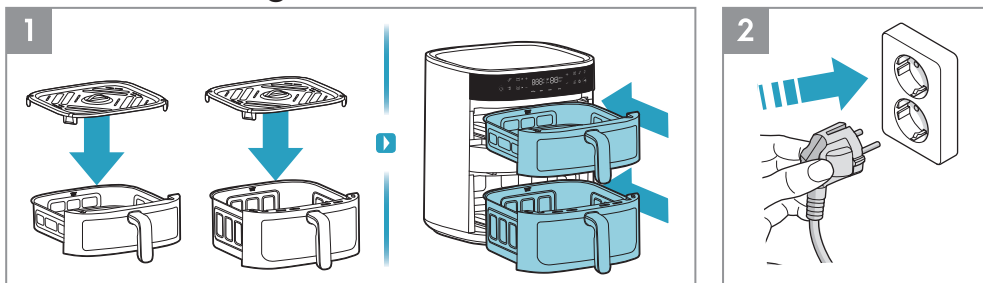

1. Før hver tilberedning skal risten placeres i kurven (den varmebestandige silikonefod på risten skal ikke fjernes), og kurven skubbes helt ind i apparatet.
2. Sæt strømstikket i stikkontakten.

Sådan bruges – enkelt kurv

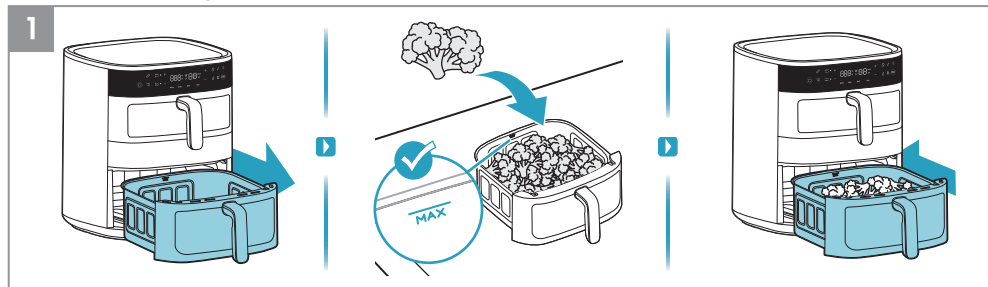

1. Træk en kurv ud, og placer den på en stabil overflade. Læg maden i kurven, og overhold kapacitetsangivelsen "MAX" (MAKS). Skub derefter kurven med maden helt tilbage i apparatet

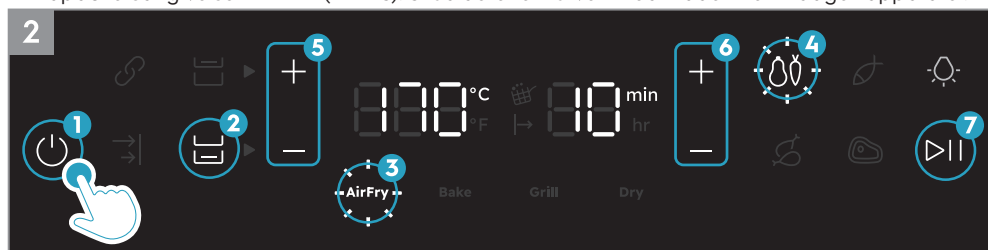

2. PTryk på Tænd/sluk-knappen. Vælg først kurven med mad. Vælg derefter den ønskede tilberedningsmetode, for eksempel Air Fry-funktionen. Juster tid og temperatur efter din smag, eller vælg en af de forudindstillede opskrifter, for eksempel Grøntsager. Tryk til sidst på Afspil/ Pause-knappen.

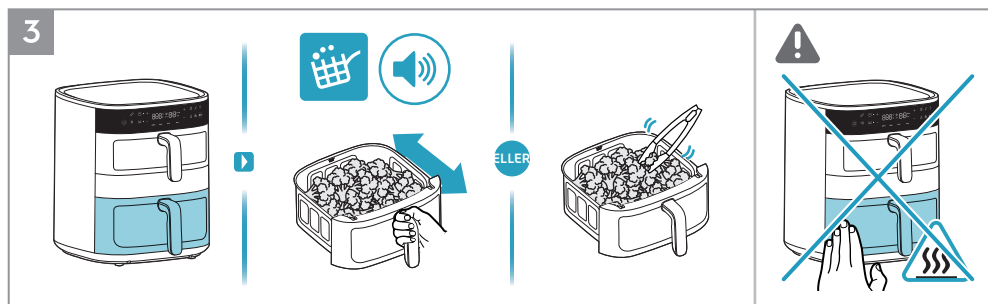

3. Når ikonet "Shake Reminder" (Påmindelse om at ryste) lyser og bipper under tilberedningen, skal du bruge varmebestandigt værktøj til at vende maden én gang eller forsigtigt ryste maden let i friturekurven.

⚠ **FORSIGTIG:** Ryst ikke friturekurven kraftigt for at undgå, at maden sprøjter ud og forårsager forbrændinger.

⚠ **FORSIGTIG:** Vær forsigtig med varme overflader, når apparatet er i brug.

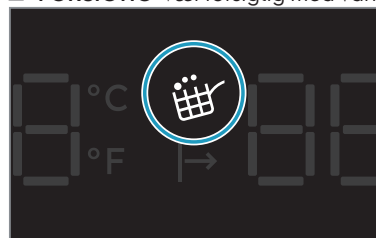

Påmindelse om at ryste

"Shake Reminder" (Påmindelse om at ryste) aktiveres under Air Fry-funktionen og de forudindstillede opskrifter, f.eks. grøntsager, fisk, kyllingelår og bøf.

Når det er tid til at ryste eller vende maden, vil ikonet "Shake Reminder" (Påmindelse om at ryste) lyse og blinke i ét minut, mens et bip gentages tre gange.

"Shake Reminder" (Påmindelse om at ryste) er ikke obligatorisk, derfor fortsætter tilberedningen som normalt, selv hvis maden ikke vendes eller rystes.



4. Ved afslutningen af tilberedningstiden afgiver apparatet et bip. Fjern forsigtigt kurven, og placer den på en varmebestandig overflade. Tag stikket ud af stikkontakten efter brug.

⚠ **FORSIGTIG:** Der kan komme varm damp ud af kurven, når den åbnes midt i eller i slutningen af tilberedningen. Sørg for, at ansigt, arme og hænder er væk fra dampen, når du åbner den.

Sådan bruges - øverste + nederste kurv

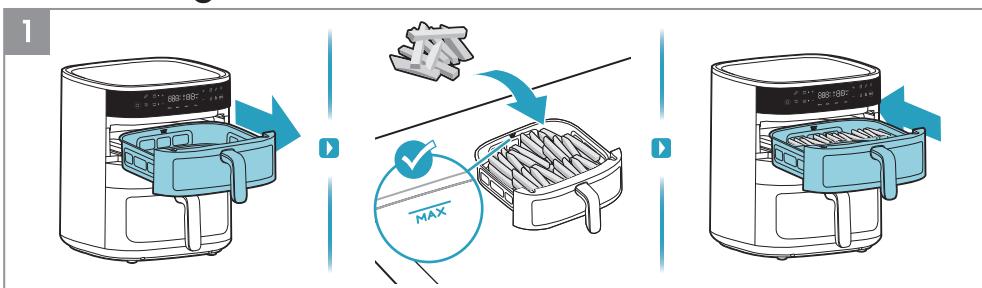

1. Træk først den øverste kurv ud, og læg maden i kurven, for eksempel pommes frites.

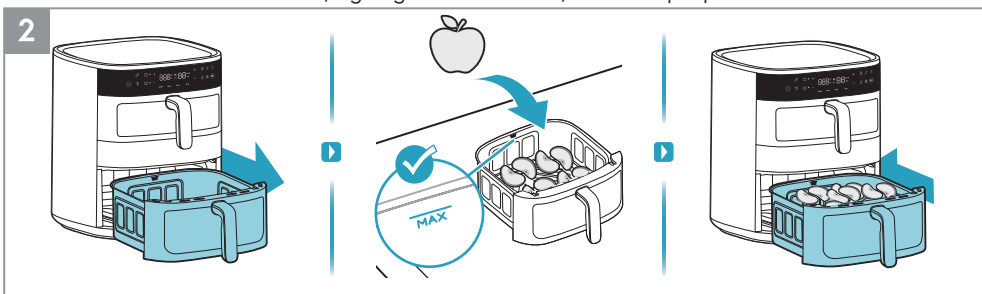

2. For det andet skal du trække den nederste kurv ud og lægge maden i kurven, for eksempel æbleskiver.



3. Tryk på Tænd/sluk-knappen. Vælg først den øverste kurv. Vælg derefter den ønskede tilberedningsmetode, for eksempel Air Fry-funktionen. Juster tid og temperatur efter din smag, eller vælg en af de forudindstillede opskrifter, for eksempel Grøntsager. Tryk til sidst på Afspil/Pause-knappen.



4. For det andet skal du vælge den nederste kurv. Vælg derefter den ønskede tilberedningsmetode, for eksempel Tørringsfunktionen. Juster tid og temperatur efter din smag. Tryk til sidst på Afspil/Pause-knappen.

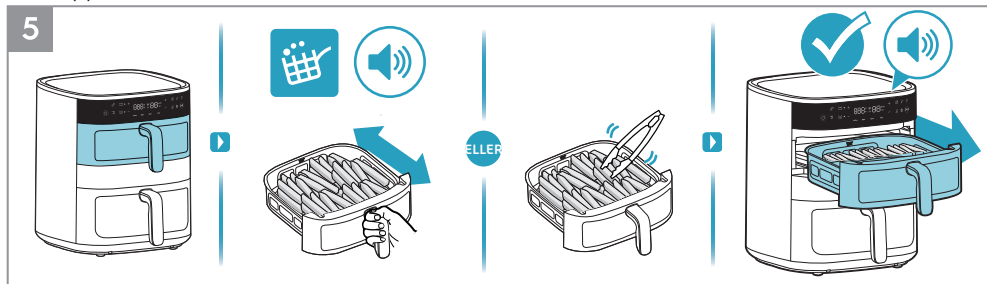

5. Når ikonet "Shake Reminder" (Påmindelse om at ryste) lyser og bipper under tilberedningen, skal du bruge varmebestandigt værktøj til at vende maden én gang eller forsigtigt ryste maden let i friturekurven. Ved afslutningen af tilberedningstiden for den øverste kurv afgiver apparatet et bip.

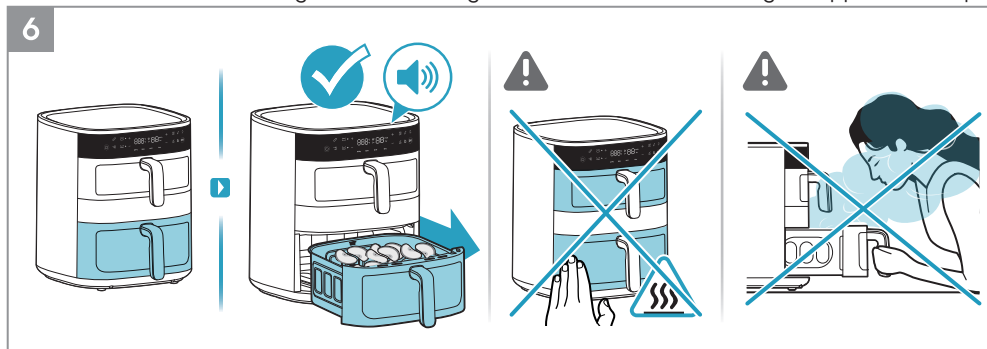

6. Når tilberedningstiden for den nederste kurv er slut, udsender apparatet et bipsignal.

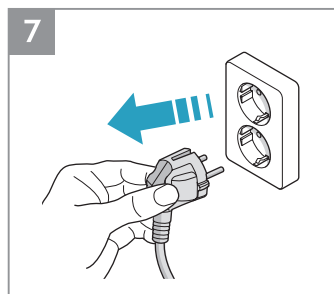

7. Tag stikket ud af stikkontakten efter brug.

Sådan bruges - Link-funktion

EN
BG
CZ
DE
DK
EE
FI
FR
GR
HR
HU
IT
LT
LV
NO
NL
PL
PT
RO
RU
SE
SI
SK
SR
TR
UA
ES
GE
AL

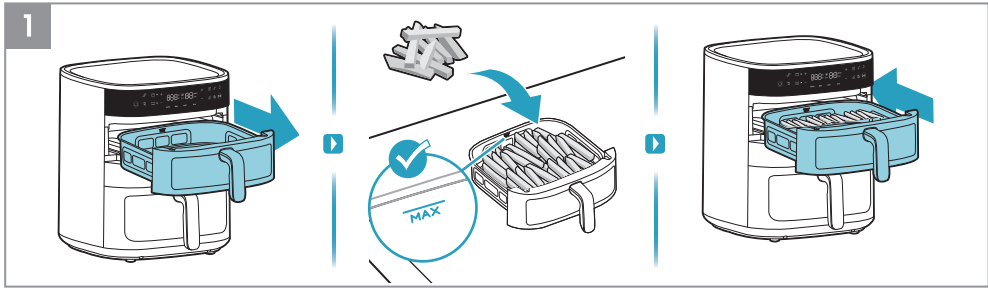

1. Træk først den øverste kurv ud, og læg maden i kurven, for eksempel pommes frites.

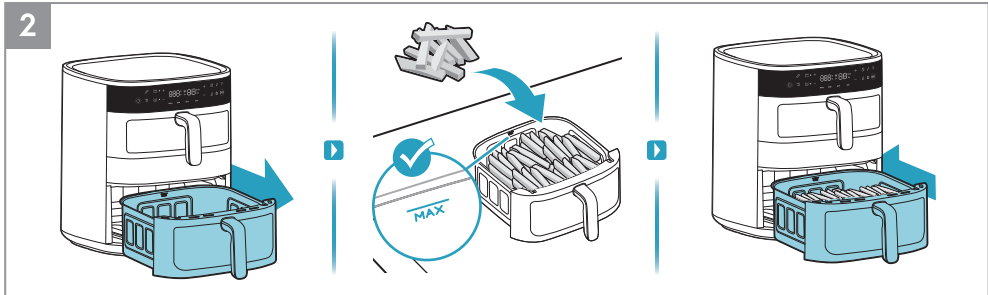

2. For det andet skal du trække den nederste kurv ud og lægge maden i kurven, for eksempel pommes frites.



3. Tryk på Tænd/sluk-knappen. Vælg først link-funktionen. Vælg derefter den ønskede tilberedningsmetode, for eksempel Air Fry-funktionen. Juster tid og temperatur efter din smag, eller vælg en af de forudindstillede opskrifter. Tryk til sidst på Afspil/Pause-knappen.

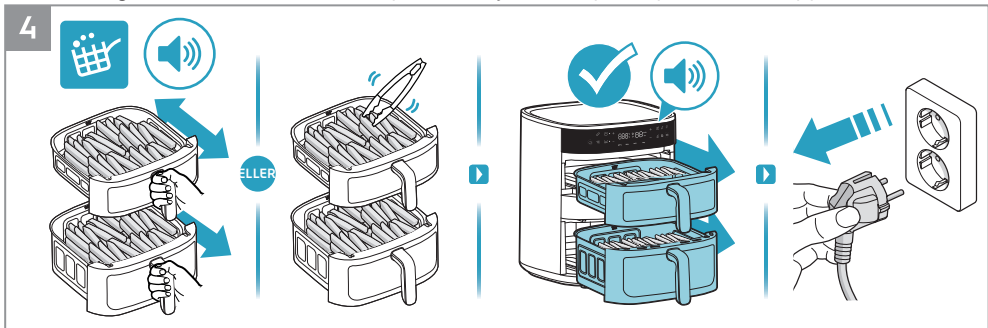

4. Når ikonet "Shake Reminder" (Påmindelse om at ryste) lyser og bipper under tilberedningen, skal du bruge varmebestandigt værktøj til at vende én gang eller forsigtigt ryste maden let i friturekurven. Ved afslutningen af tilberedningstiden afgiver apparatet et bip. Tag stikket ud af stikkontakten efter brug.

Sådan bruges - Synkroniser slut-funktion

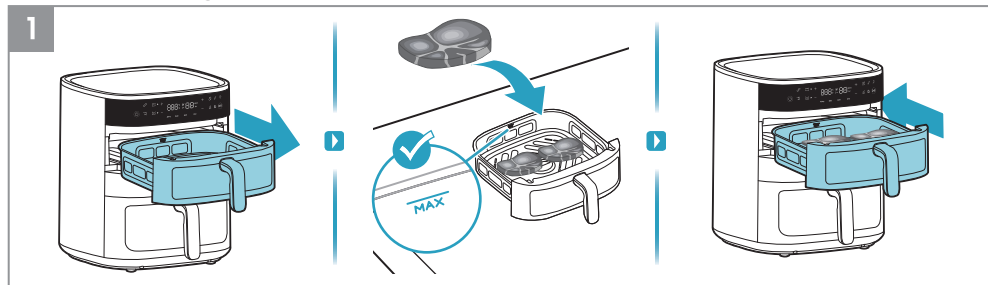

1. Træk først den øverste kurv ud, og læg maden i kurven, for eksempel en bøf.

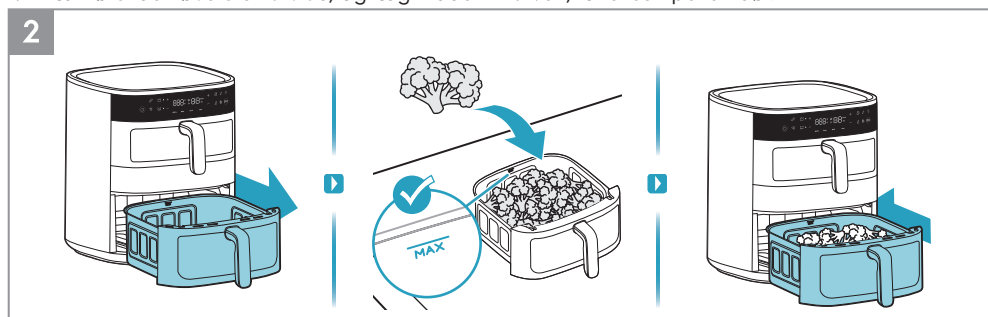

2. For det andet skal du trække den nederste kurv ud og lægge maden i kurven, for eksempel broccoli.



3. Tryk på Tænd/sluk-knappen. Vælg Synkroniser slut-funktion. Vælg først den øverste kurv, og vælg derefter den ønskede tilberedningsmetode, for eksempel Air Fry-funktionen. Juster tid og temperatur efter din smag, eller vælg en af de forudindstillede opskrifter, for eksempel Bøf.

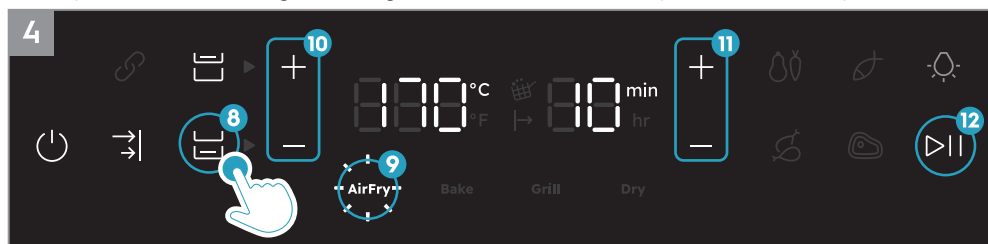

4. Vælg derefter den nederste kurv, og vælg den ønskede tilberedningsmetode, for eksempel Air Fry-funktionen. Juster tid og temperatur efter din smag, eller vælg en af de forudindstillede opskrifter. Tryk til sidst på Afspil/Pause-knappen.

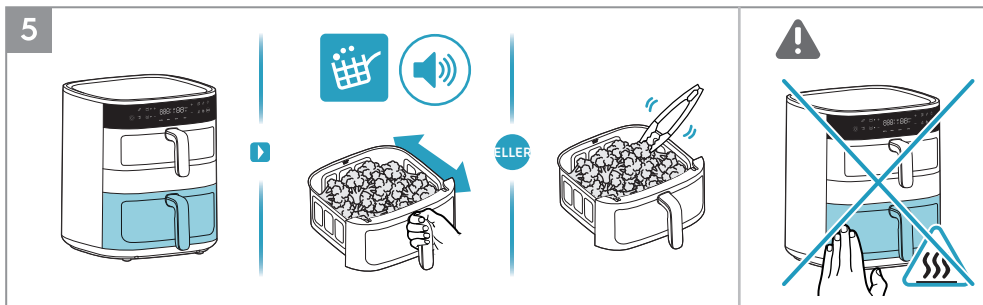

5. Først vil den nederste kurv med den længste indstillede tilberedningstid blive prioriteret til tilberedning. Når ikonet "Shake Reminder" (Påmindelse om at ryste) lyser og bipper under tilberedningen, skal du bruge varmebestandigt værktøj til at vende maten én gang eller forsigtigt ryste maten let i friturekurven.

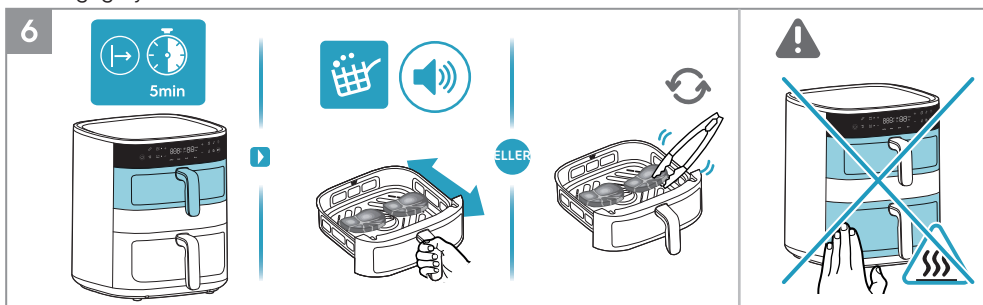

6. For det andet vil den øverste kurv med kortere indstillingstid begynde at koge. Når ikonet "Shake Reminder" (Påmindelse om at ryste) lyser og bipper under tilberedningen, skal du bruge varmebestandigt værktøj til at vende maten én gang eller forsigtigt ryste maten let i friturekurven.

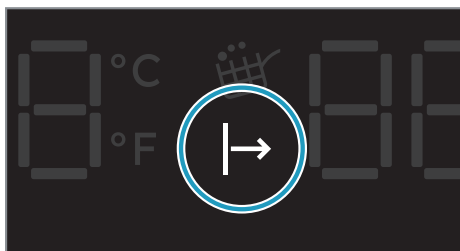

Indikator for venter på at lave mad

Når "Sync end funktion" (Synkroniser slut-funktion) er aktiveret, vil kurven med kortere tilberedningstid vente med at starte tilberedningen, indtil kurven med længere tilberedningstid har været i gang i et stykke tid, så begge kurve kan afslutte tilberedningen samtidig. I denne periode vil "Indikator for venter på at lave mad" lyse, indtil tilberedningen begynder.

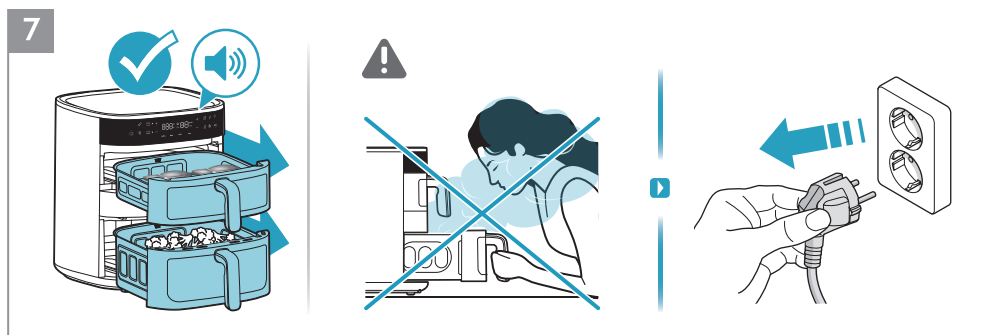

7. Ved afslutningen af tilberedningstiden afgiver apparatet et bip. Tag stikket ud af stikkontakten efter brug.

Rengøring

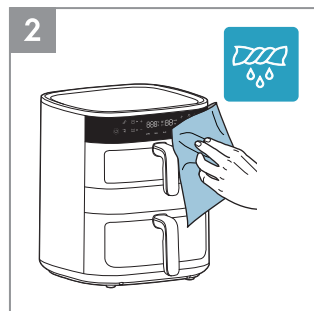
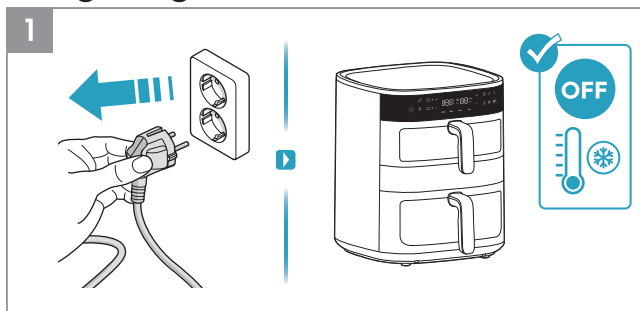

1. Tag altid stikket ud af stikkontakten, og vent med at rengøre apparatet, til det er kølet af.
2. Tør apparatets yderside af med en blød klud.

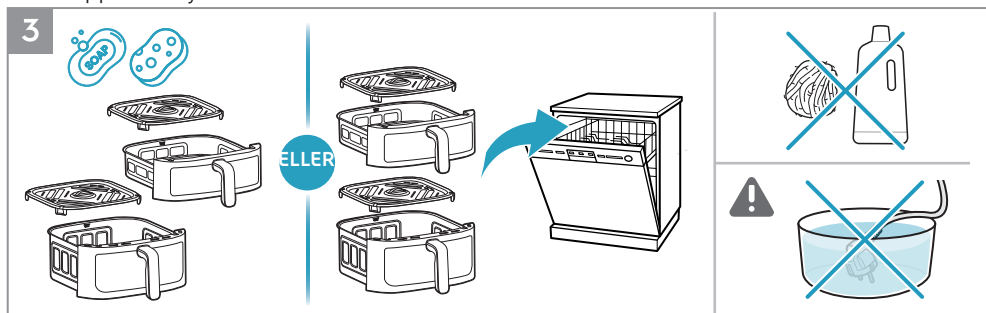

3. Rengør pande og rist med varmt vand og opvaskemiddel, eller sæt dem i opvaskemaskinen.
⚠BEMÆRK: Undgå at bruge slibende rengøringsmidler eller metalredskaber for at beskytte non-stick-belægningen.

FORSIGTIG: Nedsæk aldrig produktet, dets ledning eller stik i vand eller andre væsker.

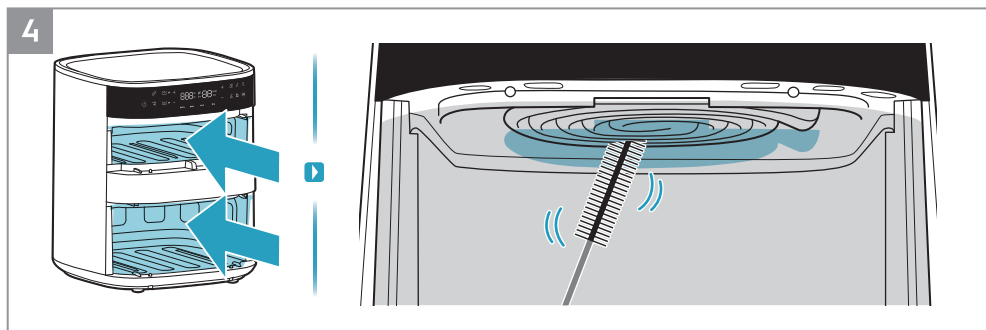

4. Rengør varmeelementet med en rengøringsbørste.













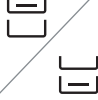













BEMÆRK: Sørg for, at apparatet er helt afkølet, før du rengør varmeelementet.

Guide til madlavning

Recipe							
AirFry	7mm/10mm 	4L	400g	180°C	18min		
		7L	400g	180°C	18min		
AirFry		4L	400g	170°C	8min		
		7L	400g	170°C	10min		
AirFry		4L	400g/2stk	140°C	15min		
		7L	400g/2stk	140°C	15min		
AirFry		4L	1000g/8stk	180°C	28min		
		7L	1000g/8stk	180°C	28min		
AirFry		4L	400g/2stk	200°C	10min		
		7L	400g/2stk	200°C	10min		
AirFry		4L	220g/6tommer	160°C	12min		
		7L	220g/6tommer	160°C	14min		

EN
BG
CZ
DE
DK
EE
FI
FR
GR
HR
HU
IT
LT
LV
NO
NL
PL
PT
RO
RU
SE
SI
SK
SR
TR
UA
ES
GE
AL

EN
BG
CZ
DE
DK
EE
FI
FR
GR
HR
HU
IT
LT
LV
NO
NL
PL
PT
RO
RU
SE
SI
SK
SR
TR
UA
ES
GE
AL

							
AirFry		7L 	1200g	180°C	55min		
AirFry		7L 	400g/9stk	160°C	20min		
Grill		4L 	180g/4stk	180°C	8min		
Grill		7L 	180g/4stk	180°C	9min		
Dry		4L 	180g	80°C	3timer		
Dry		7L 	180g	80°C	3timer		
Dry		4L 	200g	80°C	3timer		
Dry		7L 	200g	80°C	3timer		

Hvad skal man gøre hvis...

Problem	Kontroller om...
Du kan ikke aktivere eller betjene apparatet	<ul style="list-style-type: none">• Apparatet er korrekt tilsluttet en elektrisk forsyning.• Kurvene er i den rigtige position. Sørg for, at de er skubbet helt ind i apparatet for at aktivere den elektriske forsyning.• Tilberedningstiden er indstillet
Du kan ikke skubbe kurven ind i apparatet	<ul style="list-style-type: none">• Kurven er fyldt over sin maksimale kapacitet• Kurven er placeret korrekt. Den skal klikke, når du sætter den i enheden.• Der er en genstand under kurven, som er en forhindring for at lukke den ordentligt
Der kommer hvid røg ud af apparatet	<ul style="list-style-type: none">• Den mad, du laver, er for fedtet• Kurven, risten og varmeelementet er rene.
Displayet viser E1	<ul style="list-style-type: none">• Åbent kredsløb i den øverste kurven.
Displayet viser E2	<ul style="list-style-type: none">• Kortslutning i den øverste kurven.
Displayet viser E3	<ul style="list-style-type: none">• Åbent kredsløb i den nederste kurven.
Displayet viser E4	<ul style="list-style-type: none">• Kortslutning i den nederste kurven.
Displayet viser E5	<ul style="list-style-type: none">• Kommunikationsfejl i kontrol-PCBA.
Displayet viser E6	<ul style="list-style-type: none">• Power PCBA-kommunikationsfejl.

* Hvis displayet viser fejlkoder, skal apparatet repareres af et servicecenter.

Tekniske data

Produkt	Model
Model	EAFD11B
Spænding (V~)	220 V ~ 240 V
Effekt (W)	2700 W
Frekvens (Hz)	50 ~ 60 Hz
Kapacitet	4 L + 7 L



Kasutusjuhend

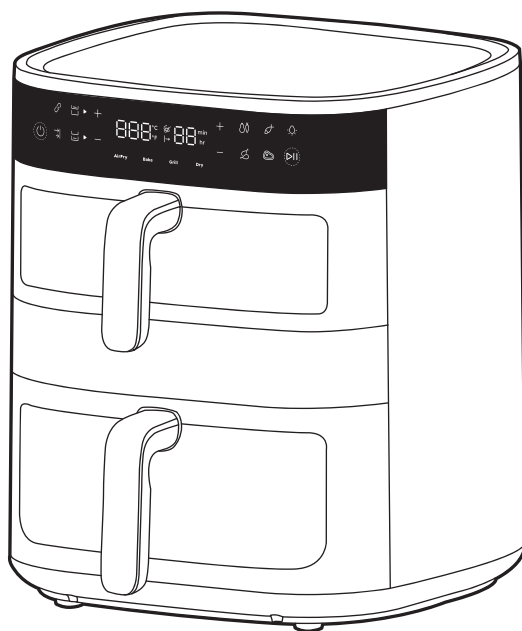

800 Kahe korviga kuumaõhufritüür

Üldine ülevaade

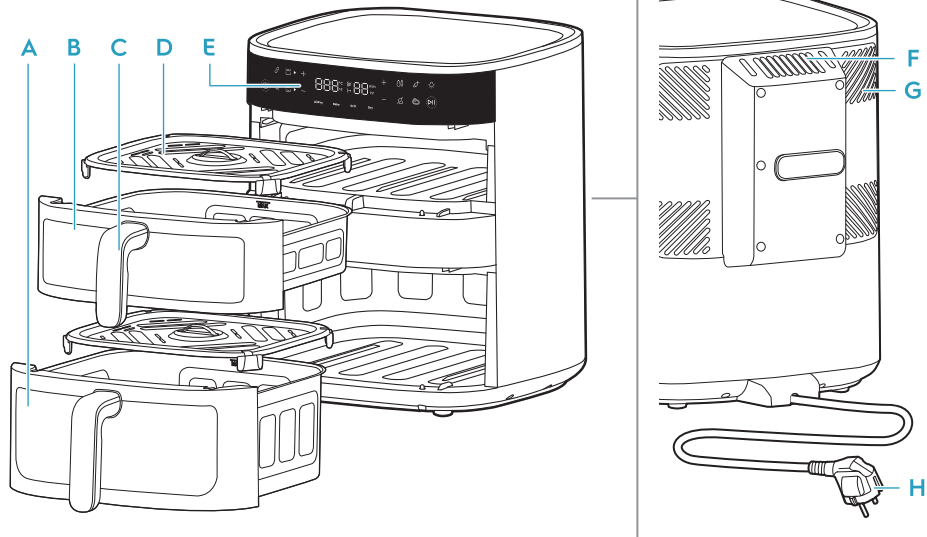

- | | | | |
|-----------------------------|------------------------|------------------------|----------------------------|
| A Alumine korv (7 l) | C Korvi käepide | E Juhtpaneel | G Jahutussüsteem |
| B Ülemine korv (4 l) | D Rest | F Õhu väljavool | H Peamine toitejuhe |

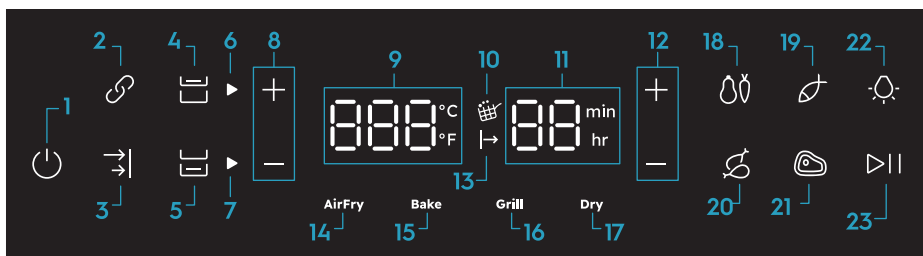

- | | | | |
|---|--|--|----------------------------|
| 1. Sees/väljas | 6. Ülemise korvi indikaator | 11. Aja indikaator (Kuumas õhuga praadimine: 1-99 minutit, kuivatamine: 1-5 tundi) | 16. Grillimise funktsioon |
| 2. Ühendamise funktsioon | 7. Alumise korvi indikaator | 12. Aja reguleerimine | 17. Kuivatuse funktsioon |
| 3. Toidu valmistamise lõpetamise sünkroniseerimise funktsioon | 8. Temperatuuri reguleerimine | 13. Toidu valmistamise ootamine | 18. Kõõgiviljad |
| 4. Ülemise korvi reguleerimine | 9. Temperatuuri indikaator (40 - 200 °C) | 14. Kuumas õhuga praadimise funktsioon | 19. Kala |
| 5. Alumise korvi reguleerimine | 10. Raputamise meeldetuletus | 15. Kõõsetamise funktsioon | 20. Kana |
| | | | 21. Lihalõik |
| | | | 22. Valgustuse kontroll |
| | | | 23. Seadme töötamine/ paus |

Enne esmakordset kasutamist

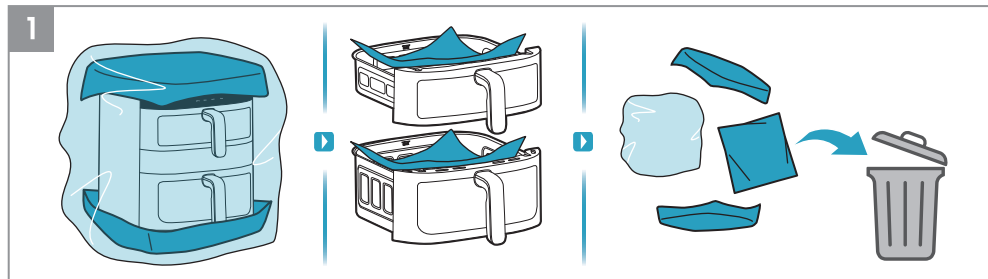

1. Eemaldage kogu pakend ja kaitsev materjal.

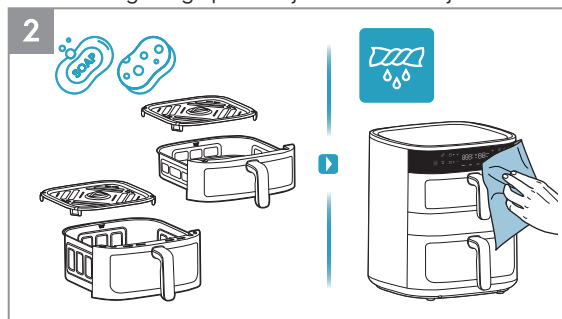

2. Puhastage pann ja rest sooja vee ja nõudepesuvahendiga. Pühkige seadme sise- ja välispinda pehme lapiga.

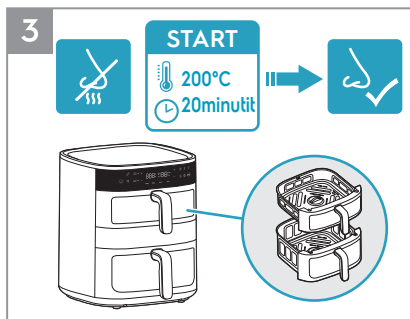



3. Uue seadme puhul on normaalne, et see eritab lõhnasid esimesel kasutamisel. Selle vältimiseks laske tühjal kuumaõhufritüüril enne esmakordset kasutamist töötada 20 minutit 200 °C juures.

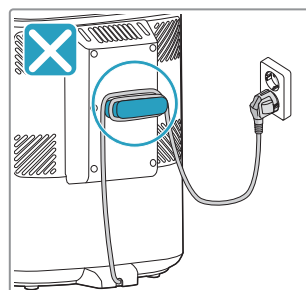
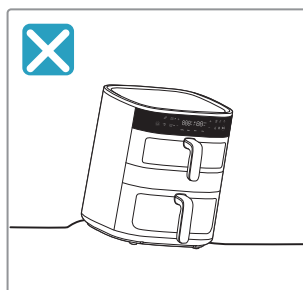
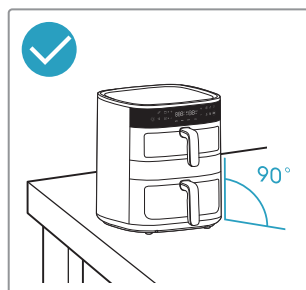
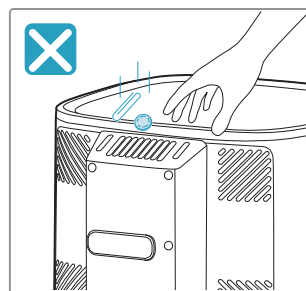
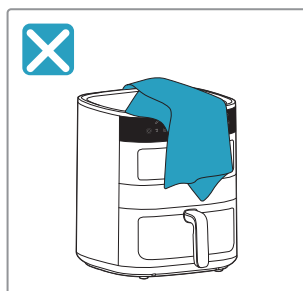



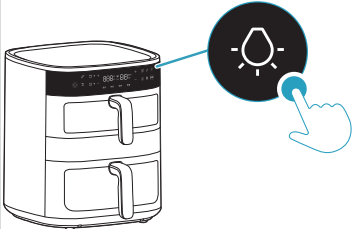
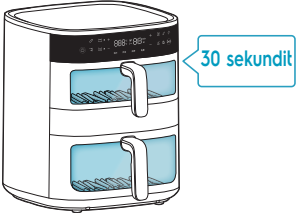

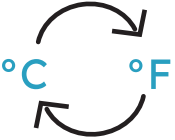







! Ohutusabinõud



Valgustuse kontroll ja temperatuuriskaala teisendamine

 <p>Valgustuse kontroll</p>		
<p>°C/°F</p> <p>Temperatuuriskaala teisendamine</p>		

Korvi valimine

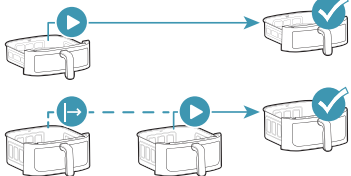
	 <p>4l</p>	 <p>7l</p>	
 <p>Ülemine korv</p>			
 <p>Alumine korv</p>			
 <p>Ühendamise funktsioon</p>			
 <p>Toidu valmistamise lõpetamise sünkroniseerimise funktsioon</p>			

Algselt seadistatud funktsioonid

AirFry	180°C	15minutit	60-200°C	1-99minutit	
	170°C	10minutit	60-200°C	1-99minutit	
	140°C	15minutit	60-200°C	1-99minutit	
	180°C	30minutit	60-200°C	1-99minutit	
	200°C	10minutit	60-200°C	1-99minutit	
Bake	170°C	15minutit	60-200°C	1-99minutit	
Grill	200°C	5minutit	60-200°C	1-99minutit	
Dry	80°C	5tundi	40-80°C	1-5tundi	

Enne toidu valmistamist

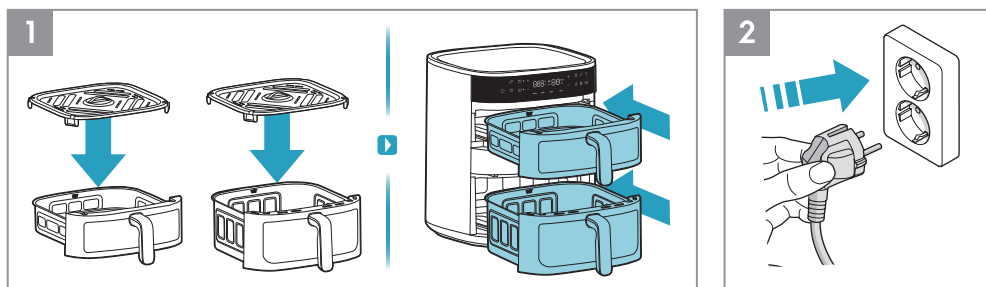

1. Enne iga toidu valmistamist asetage rest korvi (resti kuumakindlat silikoonist jala patja ei ole vaja eemaldada) ja lükake korv täielikult seadmesse.
2. Ühendage toitejuhe vooluvõrku.

Kuidas kasutada - ühte korvi

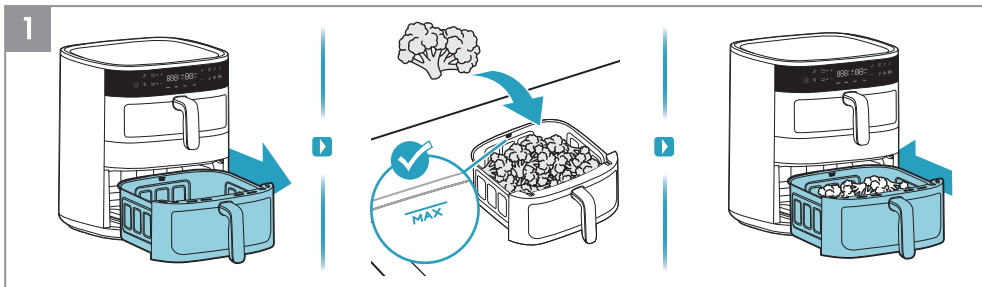

1. Tõmmake üks korv välja ja asetage see stabiilsele pinnale, pange toit korvi, jälgides mahutavuse tähist "MAX". Seejärel lükake korv koos toiduga täielikult seadmesse tagasi.



2. Vajutage sisse-/väljalülitamise nupule. Valige kõigepealt toiduga korv. Seejärel valige soovitud toidu valmistamise viis, näiteks kuum õhuga praadimise funktsioon. Reguleerige aega ja temperatuuri vastavalt oma eelistusele või valige üks algselt seadistatud retseptidest, näiteks köögivilja retsept. Lõpuks vajutage seadme töötamise/stoppi nupule.

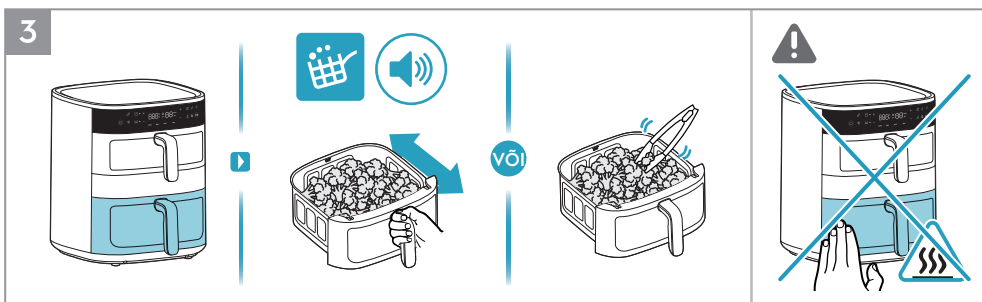

3. Kui toidu valmistamise ajal süttib ikoon "Raputamise meeldetuletus" ja kostab piiks, keerake toit üks kord kuumakindlate tööriistade abil ümber või raputage toitu praadimiskorvis ettevaatlikult kergelt.

⚠ **ETTEVAATUST:** Ärge raputage praadimiskorvi tugevasti, et vältida toidu pritsimist ja põletusi.

⚠ **ETTEVAATUST:** Olge seadme kasutamise ajal kuumade pindade suhtes ettevaatlik.

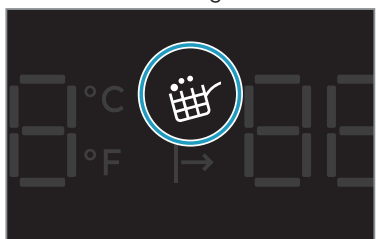

Raputamise meeldetuletus

"Raputamise meeldetuletus" aktiveeritakse kuum õhuga praadimise funktsiooni ja algselt seadistatud retseptide, näiteks köögiviljade, kala, kanakoibade ja lihalõikude puhul.

Kui on aeg teie toitu raputada või keerata, süttib ikoon "Raputamise meeldetuletus" ja see vilgub ühe minuti jooksul, samal ajal kui helisignaali korratakse kolm korda.

"Raputamise meeldetuletusele" reageerimine ei ole kohustuslik, sest pärast seda jätkub toidu valmistamine tavapäraselt isegi siis, kui toitu ei keerata ega raputata.



4. Toidu valmistamise aja lõppemisel kostub helisignaal. Eemaldage korv ettevaatlikult ja asetage see kuumakindlale pinnale. Pärast seadme kasutamist eemaldage see vooluvõrgust.

⚠ **ETTEVAATUST:** Korvist võib tulla kuuma auru siis, kui see avatakse toidu valmistusaja keskel või selle lõpus. Avamisel veenduge, et teie nägu, käed ja peopesad oleksid aurust eemal.

Kuidas kasutada - ülemist + alumist korvi

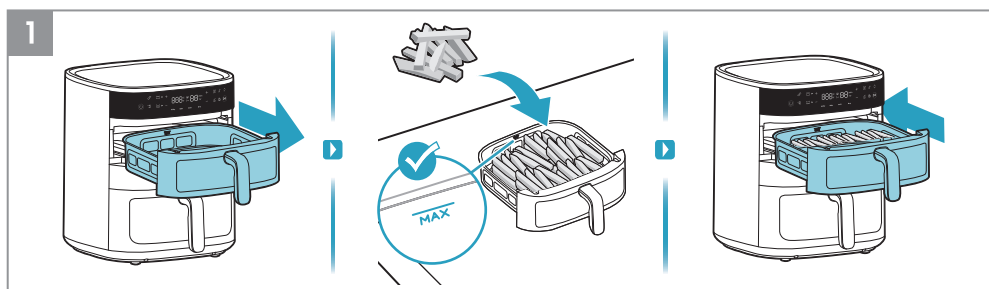

1. Kõigepealt tõmmake ülemine korv välja ja pange toit korvi, näiteks friikartulid.

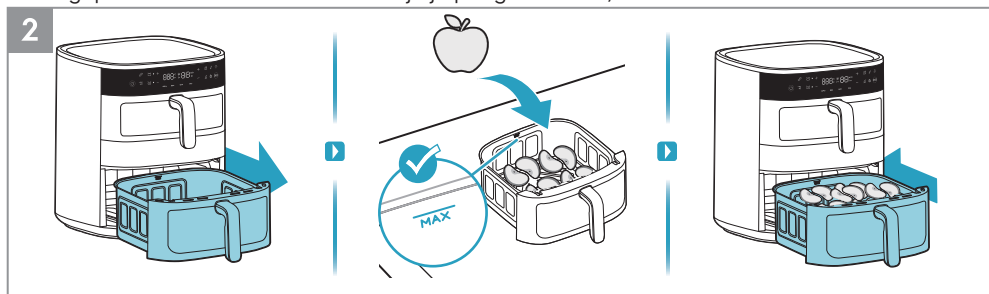

2. Teisena tõmmake alumine korv välja ja pange toit korvi, näiteks õunaviilud.



3. Vajutage sisse-/väljalülitamise nupule. Valige kõigepealt ülemine korv. Seejärel valige soovitud toidu valmistamise viis, näiteks kuum õhuga praadimise funktsioon. Reguleerige aega ja temperatuuri vastavalt oma eelistusele või valige üks algselt seadistatud retseptidest, näiteks köögivilja retsept. Lõpuks vajutage seadme töötamise/stopp nupule.



4. Teisena valige alumine korv. Seejärel valige soovitud toidu valmistamise viis, näiteks kuivatufunktsioon. Reguleerige aega ja temperatuuri vastavalt oma eelistusele. Lõpuks vajutage seadme töötamise/stop nupule.

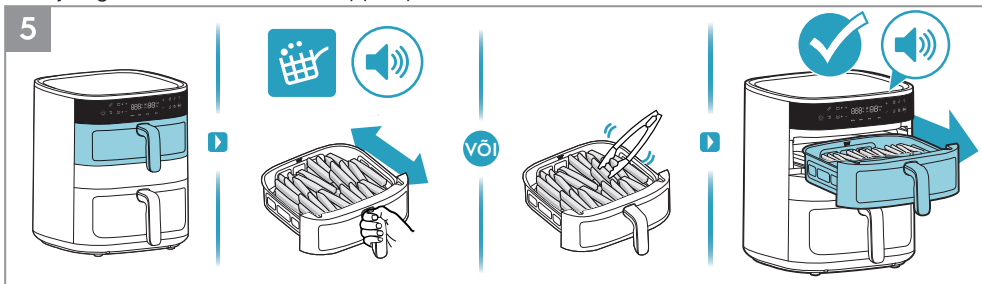

5. Kui toidu valmistamise ajal süttib ikoon "Raputamise meeldetuletus" ja kostab piiks, keerake toit üks kord kuumakindlate tööriistade abil ümber või raputage toitu pradamiskorvis ettevaatlikult kergelt. Ülemise korvi toidu valmistamise aja lõppemisel kostub helisignaali.

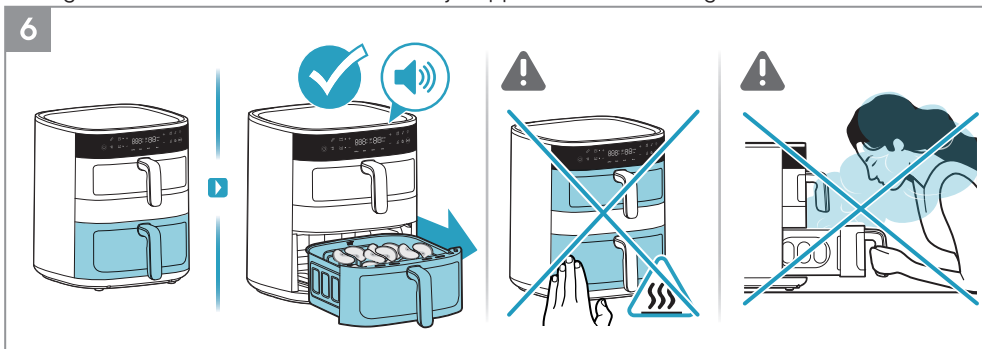

6. Alumise korvi toidu valmistamise aja lõppemisel kostub helisignaali.

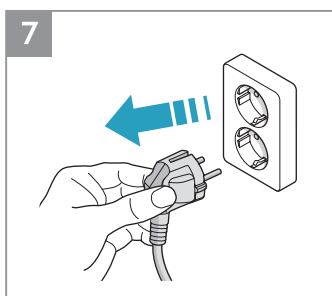

7. Pärast seadme kasutamist eemaldage see vooluvõrgust.

EN
BG
CZ
DE
DK
EE
FI
FR
GR
HR
HU
IT
LT
LV
NO
NL
PL
PT
RO
RU
SE
SI
SK
SR
TR
UA
ES
GE
AL

Kuidas kasutada - ühendamise funktsiooni

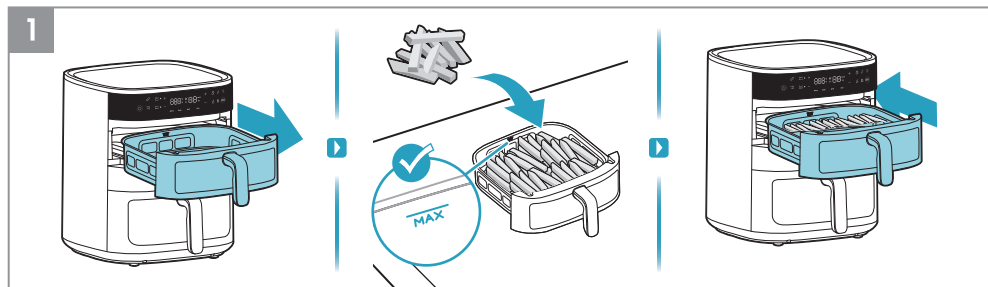

1. Kõigepealt tõmmake ülemine korv välja ja pange toit korvi, näiteks friikartulid.

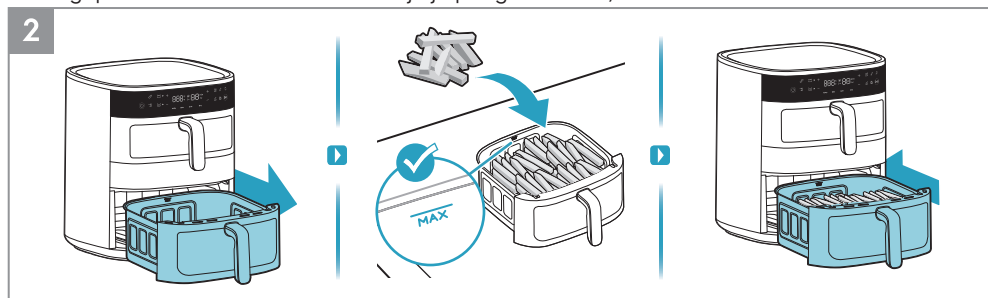

2. Teisena tõmmake alumine korv välja ja pange toit korvi, näiteks friikartulid.



3. Vajutage sisse-/väljalülitamise nupule. Valige kõigepealt ühendamise funktsioon. Seejärel valige soovitud toidu valmistamise viis, näiteks kuum õhuga praadimise funktsioon. Reguleerige aega ja temperatuuri vastavalt oma eelistusele või valige üks algselt seadistatud retseptidest. Lõpuks vajutage seadme töötamise/stopp nupule.

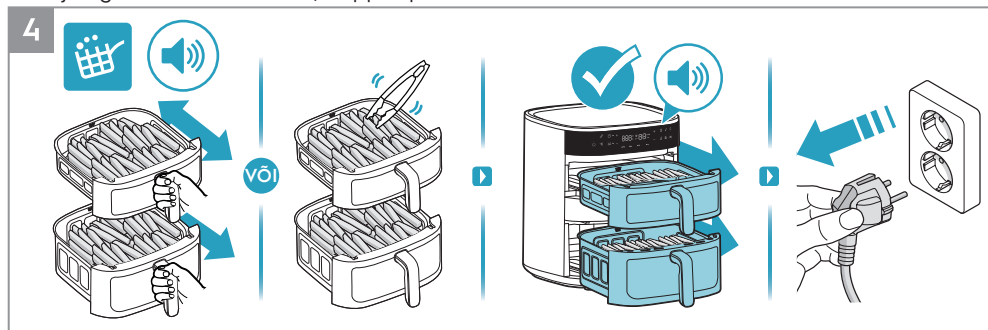

4. Kui toidu valmistamise ajal süttib ikoon "Raputamise meeldetuletus" ja kostab piiks, keerake toit üks kord kuumakindlate tööriistade abil ümber või raputage toitu praadimiskorvis ettevaatlikult kergelt. Toidu valmistamise aja lõppemisel kostub helisignaali. Pärast seadme kasutamist eemaldage see vooluvõrgust.

Kuidas kasutada - toidu valmistamise lõpetamise sünkroniseerimise funktsiooni

EN
BG
CZ
DE
DK
EE
FI
FR
GR
HR
HU
IT
LT
LV
NO
NL
PL
PT
RO
RU
SE
SI
SK
SR
TR
UA
ES
GE
AL

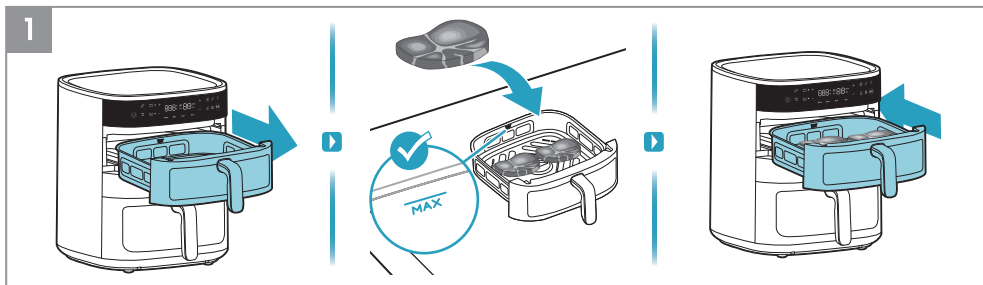

1. Kõigepealt tõmmake ülemine korv välja ja pange toit korvi, näiteks lihalõigud.

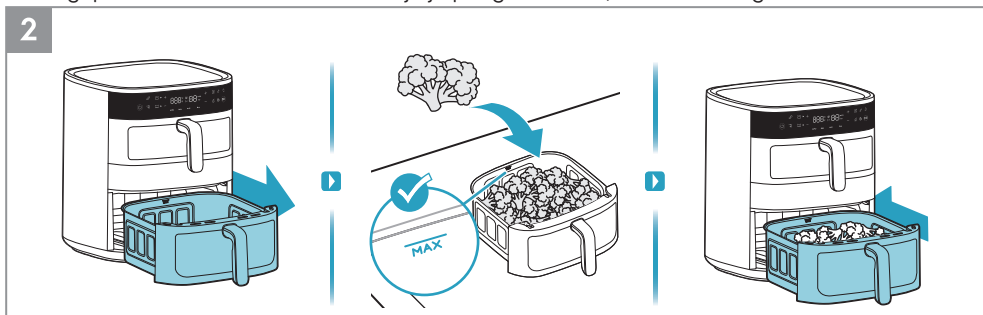

2. Teisena tõmmake alumine korv välja ja pange toit korvi, näiteks brokoli.



3. Vajutage sisse-/väljalülitamise nupule. Valige toidu valmistamise lõpetamise sünkroniseerimise funktsioon. Valige kõigepealt ülemine korv, seejärel valige soovitud toidu valmistamise viis, näiteks kuuma õhuga praadimise funktsioon. Reguleerige aega ja temperatuuri vastavalt oma eelistusele või valige üks algselt seadistatud retseptidest, näiteks lihalõikude retsept



4. Ja seejärel valige alumine korv, valige soovitud toidu valmistamise viis, näiteks kuuma õhuga praadimise funktsioon. Reguleerige aega ja temperatuuri vastavalt oma eelistusele või valige üks algselt seadistatud retseptidest. Lõpuks vajutage seadme töötamise/stopp nupule.

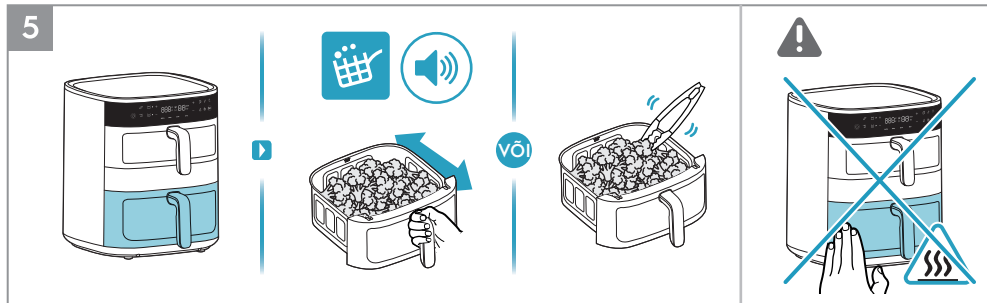

5. Kõigepealt antakse toidu valmistamiseks eesõigus alumisele korvile, milles oleval toidul on pikem valmistusaeg. Kui toidu valmistamise ajal süttib ikoon „Raputamise meeldetuletus“ ja kostab piiks, keerake toit üks kord kuumakindlate tööriistade abil ümber või raputage toitu praadimiskorvis ettevaatlikult kergelt.

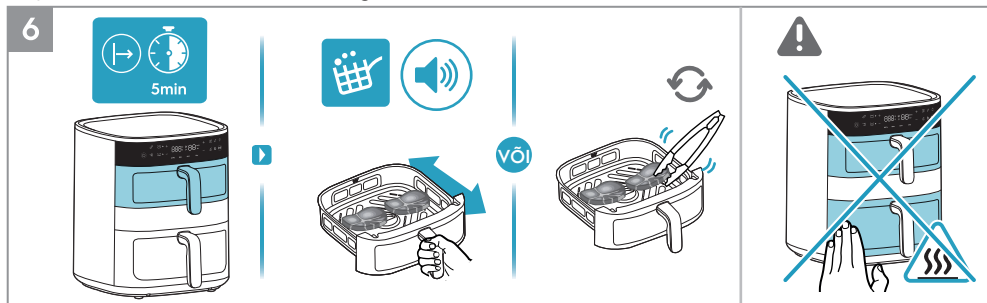

6. Teisena algab toidu valmistamine ülemises korvis, millele on seadistatud lühem valmistusaeg. Kui toidu valmistamise ajal süttib ikoon „Raputamise meeldetuletus“ ja kostab piiks, keerake toit üks kord kuumakindlate tööriistade abil ümber või raputage toitu praadimiskorvis ettevaatlikult kergelt.

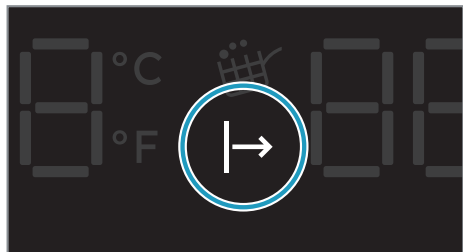

Toidu valmistamise indikaatori süttimise ootamine

Kui „Toidu valmistamise lõpetamise sünkroniseerimise funktsioon“ on aktiveeritud, ootab lühema seadistatud toidu valmistamise ajaga korv toidu valmistamisega mõnda aega, kuni pikema seadistatud toidu valmistamise ajaga korvis valmistatakse toitu selleks, et mõlemad korvid saaksid lõpetada toidu valmistamise samaaegselt. Selle aja jooksul põleb „toidu valmistamise indikaatori süttimise ootamine“ kuni toidu valmistamise alguseni.

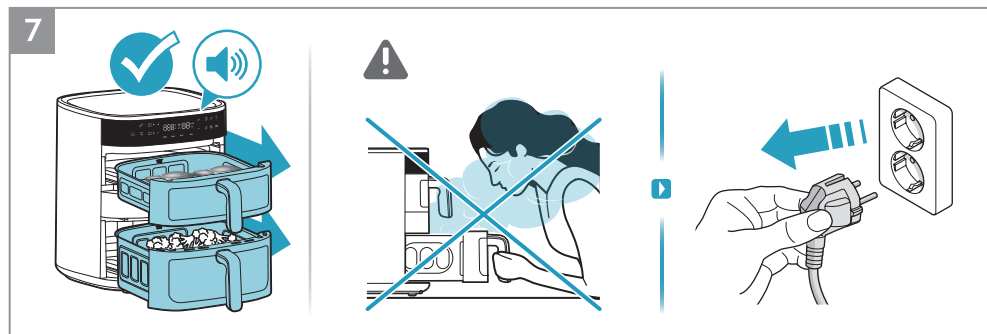

7. Toidu valmistamise aja lõppemisel kostub helisignaali. Pärast seadme kasutamist eemaldage see vooluvõrgust.

Puhastamine

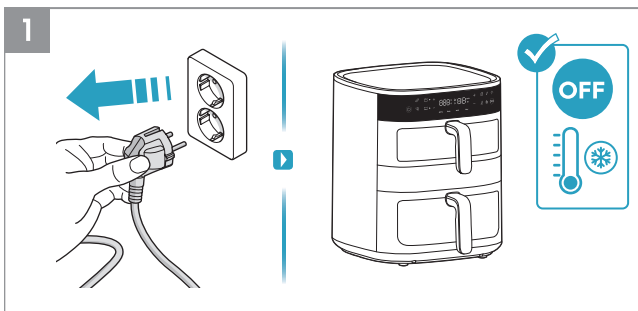

1. Enne seadme puhastamist eemaldage see alati vooluvõrgust ja oodake, kuni see jahtub.
2. Pühkige seadme välispinda pehme lapiga.

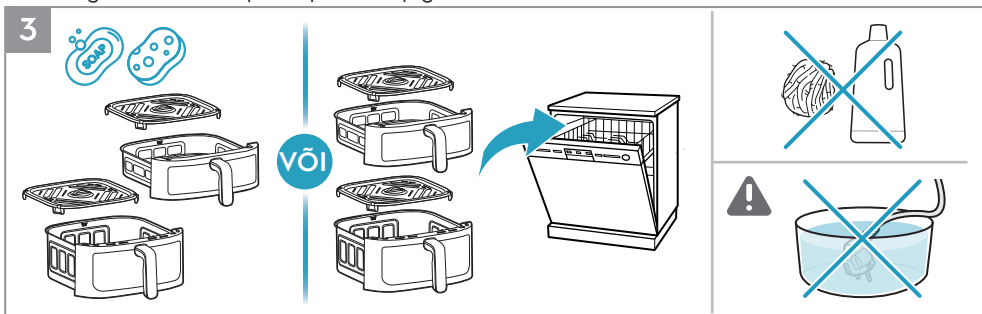

3. Puhastage pann ja rest sooja vee ja nõudepesuvahendiga või pange need nõudepesumasinasse.

MÄRKUS: Mittenakkuva katte kaitsmiseks vältige abrasiivsete puhastusvahendite või metallist abivahendite kasutamist.

ETTEVAATUST: Mitte kunagi ärge kastke seadet, toitejuhet või pistikut vette või mis tahes teise vedelikku.

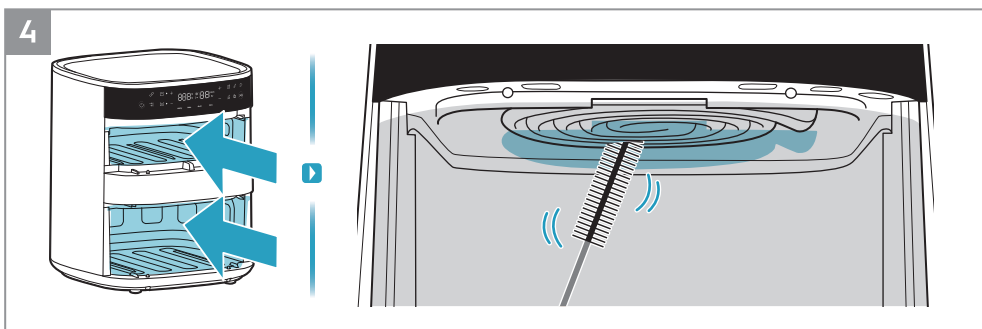











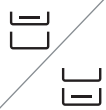























































4. Puhastage kütteelementi puhastusharjaga.

MÄRKUS: Enne kütteelemendi puhastamist veenduge, et seade on täielikult jahtunud.

EN
BG
CZ
DE
DK
EE
FI
FR
GR
HR
HU
IT
LT
LV
NO
NL
PL
PT
RO
RU
SE
SI
SK
SR
TR
UA
ES
GE
AL

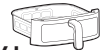
Toidu valmistamise juhised

							
	7mm/10mm 	 4l	400g	180°C	18minutit		
		 7l	400g	180°C	18minutit		
		 4l	400g	170°C	8minutit		
		 7l	400g	170°C	10minutit		
		 4l	400g/2tk	140°C	15minutit		
		 7l	400g/2tk	140°C	15minutit		
		 4l	1000g/8tk	180°C	28minutit		
		 7l	1000g/8tk	180°C	28minutit		
		 4l	400g/2tk	200°C	10minutit		
		 7l	400g/2tk	200°C	10minutit		
		 4l	220g/6tolli	160°C	12minutit		
		 7l	220g/6tolli	160°C	14minutit		

							
AirFry		 7l	1200g	180°C	55minutit		
AirFry		 7l	400g/9tk	160°C	20minutit		
Grill		 4l	180g/4tk	180°C	8minutit		
		 7l	180g/4tk	180°C	9minutit		
Dry		 4l	180g	80°C	3tundi		
		 7l	180g	80°C	3tundi		
Dry		 4l	200g	80°C	3tundi		
		 7l	200g	80°C	3tundi		

- EN
- BG
- CZ
- DE
- DK
- EE**
- FI
- FR
- GR
- HR
- HU
- IT
- LT
- LV
- NO
- NL
- PL
- PT
- RO
- RU
- SE
- SI
- SK
- SR
- TR
- UA
- ES
- GE
- AL

Mida teha, kui ...

Probleem	Kontrollige, kui ...
Te ei saa seadet sisse lülitada või kasutada.	<ul style="list-style-type: none"> • Seade on ühendatud õigesti elektrivõrku. • Korvid on õiges asendis. Veenduge, et need oleksid lükatud täielikult seadmesse, et tagada elektrivarustus. • Toidu valmistamise aeg on seadistatud.
Te ei saa lükata korvi seadmesse.	<ul style="list-style-type: none"> • Korv on täidetud üle selle maksimaalse mahutavuse. • Korv on paigutatud õigesti. See peab seadmesse asetamisel tegema klõpsu. • Korvi all on ese, mis takistab selle korralikku sulgemist.
Seadmeist tuleb välja valget suitsu.	<ul style="list-style-type: none"> • Teie valmistatav toit on liiga rasvane. • Korv, rest ja küttekeha on puhtad.
Ekraanil kuvatakse E1	<ul style="list-style-type: none"> • Ülemise korvi avatud ahel.
Ekraanil kuvatakse E2	<ul style="list-style-type: none"> • Ülemise korvi lühis.
Ekraanil kuvatakse E3	<ul style="list-style-type: none"> • Alumise korvi avatud ahel.
Ekraanil kuvatakse E4	<ul style="list-style-type: none"> • Alumise korvi lühis.
Ekraanil kuvatakse E5	<ul style="list-style-type: none"> • Juht-PCBA side rike.
Ekraanil kuvatakse E6	<ul style="list-style-type: none"> • Toite PCBA side rike.

* Juhul, kui ekraanil kuvatakse veakoode, peab seadet remontima hoolduskeskuses.

Tehnilised andmed

Toode	Kuumaõhufritüür
Mudel	EAFD11B
Pinge (V~)	220 V - 240 V
Võimsus (W)	2700 W
Sagedus (Hz)	50 ~ 60 Hz
Mahutavus	4 l + 7 l



Ohjekirja

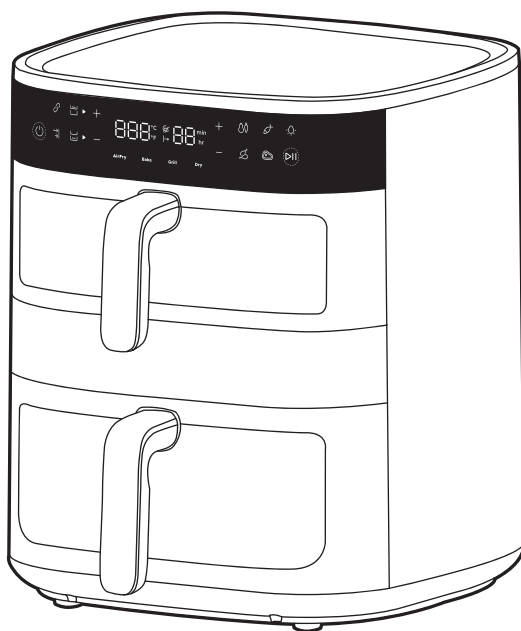

800 Air Fryer Dual

Yleiskatsaus

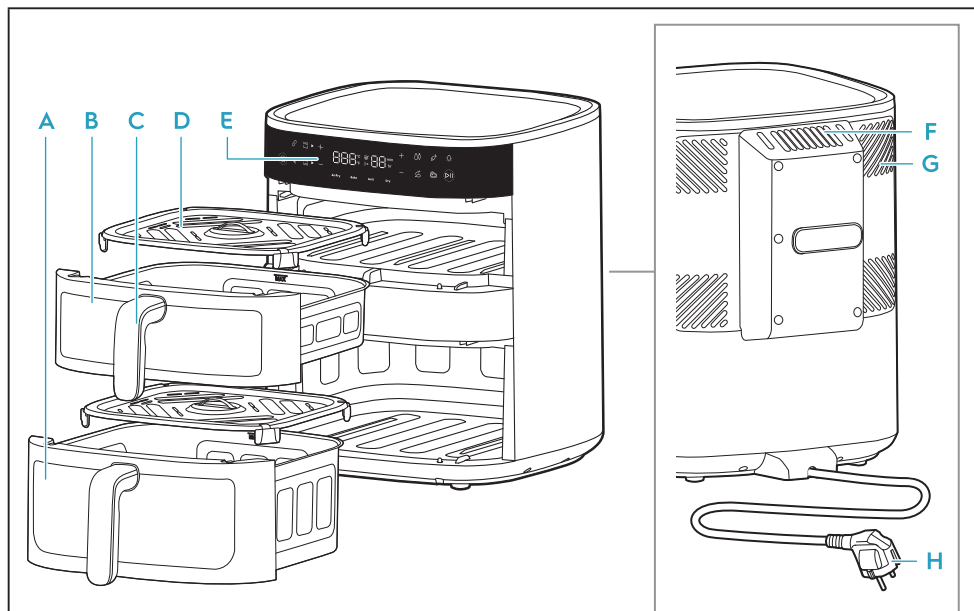

- | | | | |
|------------------------|----------------------|---------------------------|-------------------------------|
| A Alakori (7 l) | C Korin kahva | E Ohjauspaneeli | G Jäähdytysjärjestelmä |
| B Yläkori (4 l) | D Ruudukko | F Ilmanpoistoaukko | H Pääjohto |

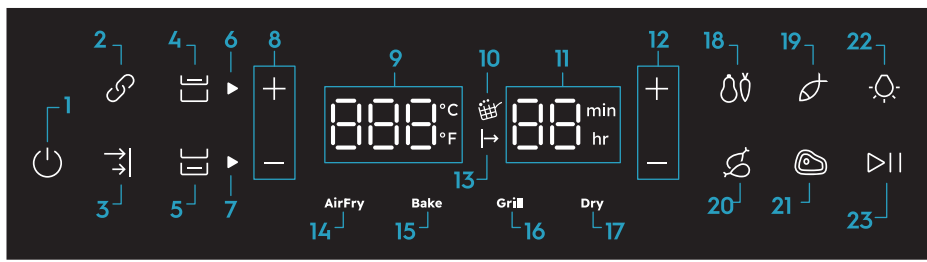

- | | | | |
|---------------------------------|------------------------------------|--------------------------|---------------------|
| 1. On/Off (Päälle/Pois) | 9. Lämpötilan ilmaisin (40-200 °C) | 13. Odottaa ruoanlaittoa | 21. Pihvi |
| 2. Linkkitoiminto | 10. Ravistusmuistutus | 14. AirFry-toiminto | 22. Valon hallinta |
| 3. Synkronoinnin päättötoiminto | 11. Aikailmaisin (AirFry) | 15. Paisto-toiminto | 23. Toista/Keskeytä |
| 4. Yläkorin hallinta | 12. Odottaa ruoanlaittoa (+/-) | 16. Grillitoiminto | |
| 5. Alakorin hallinta | 13. Odottaa ruoanlaittoa | 17. Kuivaustoiminto | |
| 6. Yläkorin ilmaisin | 14. AirFry-toiminto | 18. Vihannekset | |
| 7. Alakorin ilmaisin | 15. Paisto-toiminto | 19. Kala | |
| 8. Lämpötilan hallinta (+/-) | 16. Grillitoiminto | 20. Kana | |
| | 17. Kuivaustoiminto | | |
| | 18. Vihannekset | | |
| | 19. Kala | | |
| | 20. Kana | | |
| | 21. Pihvi | | |
| | 22. Valon hallinta | | |
| | 23. Toista/Keskeytä | | |

Ennen ensimmäistä käyttöä

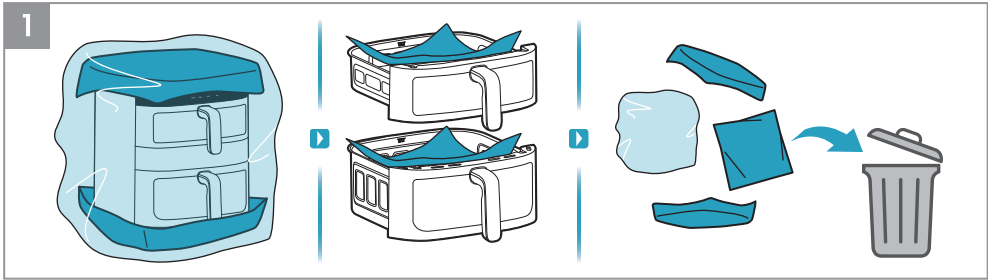

1. Poista kaikki pakkaus- ja suojamateriaalit

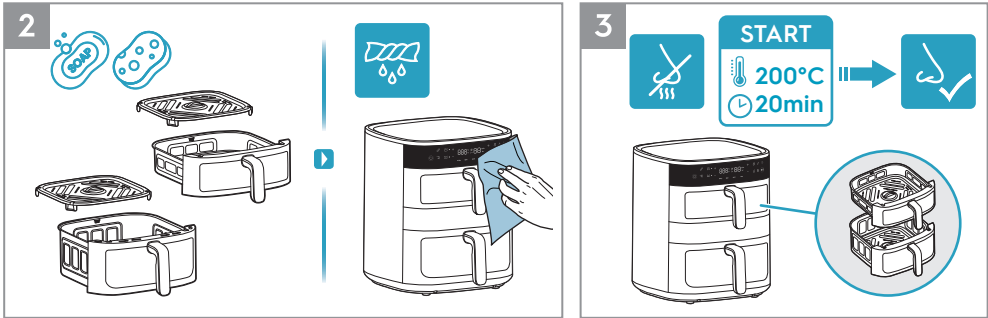

2. Puhdista pannu ja ritilä lämpimällä vedellä ja astianpesuaineella. Pyyhi laitteen sisä- ja ulkopinnat pehmeällä liinalla.

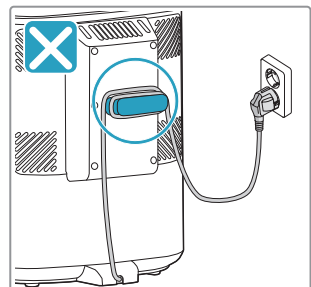
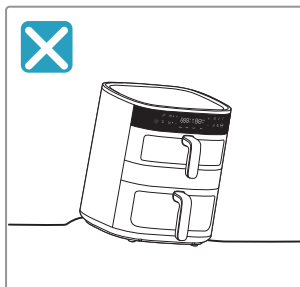
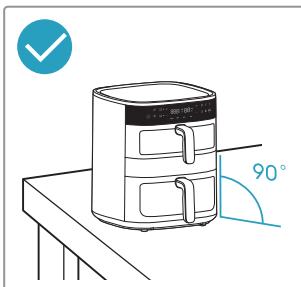
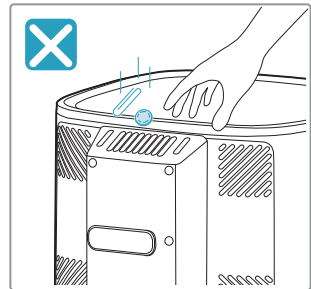
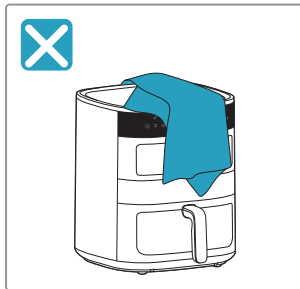
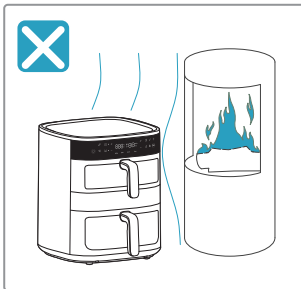

3. On normaalia, että uusi laite tuottaa hajua ensimmäisten käyttökertojen aikana. Käynnistä tyhjä ilmakeitin 200 °C:ssa 20 minuutin ajan ennen ensimmäistä käyttökertaa, jotta vältät tämän.

! Turvallisuuden varotoimet





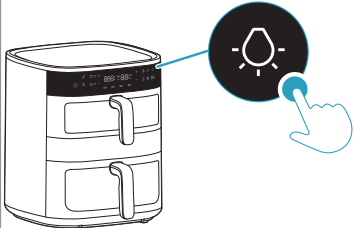
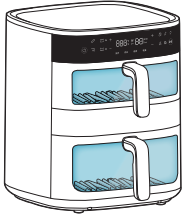

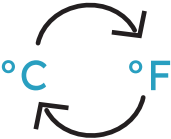









EN
BG
CZ
DE
DK
EE
FI
FR
GR
HR
HU
IT
LT
LV
NO
NL
PL
PT
RO
RU
SE
SI
SK
SR
TR
UA
ES
GE
AL







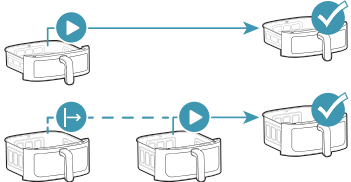







Valaistuksen ohjaus ja lämpötila-asteikon muunnos

 <p>Valaistuksen ohjaus</p>		 <p>30 sekuntia</p>
<p>°C/°F</p> <p>Lämpötila-asteikon muuntaminen</p>	 <p>30 sekuntia</p>	

Korin valinta

	 <p>41</p>	 <p>71</p>	
 <p>Yläkori</p>			
 <p>Alakori</p>			
 <p>Linkkitoiminto</p>			
 <p>Synkronoinnin päättötoiminto</p>			

Valmiit toiminnot

 AirFry					
AirFry	180°C	15min	60-200°C	1-99min	
	170°C	10min	60-200°C	1-99min	
	140°C	15min	60-200°C	1-99min	
	180°C	30min	60-200°C	1-99min	
	200°C	10min	60-200°C	1-99min	
Bake	170°C	15min	60-200°C	1-99min	
Grill	200°C	5min	60-200°C	1-99min	
Dry	80°C	5h	40-80°C	1-5h	

Ennen kypsennystä

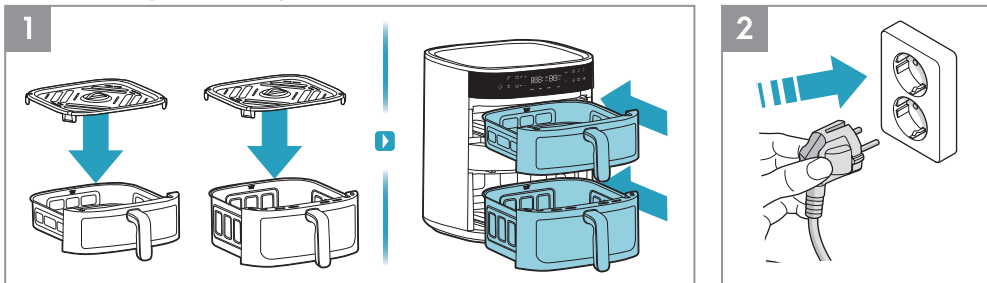

1. Ennen jokaista kypsennystä aseta ritilä koriin (ritilän lämmönkestävää silikonijalkapohjaa ei tarvitse poistaa) ja työnnä kori kokonaan laitteeseen.
2. Kytke virtajohto pistorasiaan.

Käyttöohjeet - Yksittäinen kori

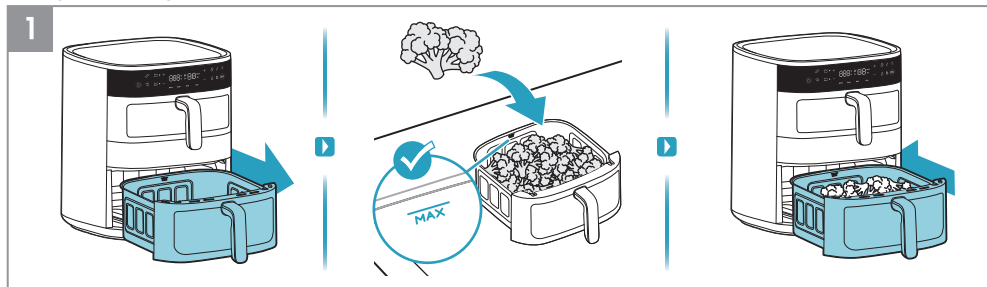

1. Vedä yksi kori ulos ja aseta se vakaalle alustalle, laita ruoka koriin noudattaen "MAX"-kapasiteettimerkintää. Työnä sitten kori, jossa on ruokaa kokonaan takaisin laitteeseen.



2. Paina Päälle/Pois-painiketta. Valitse ensin kori, jossa on ruokaa. Valitse sitten haluamasi kypsennysmenetelmä, esimerkiksi Air Fry -toiminto. Säädä aika ja lämpötila makusi mukaan tai valitse yksi valmiista resepteistä, esimerkiksi Vihannekset. Lopuksi paina Toisto/Keskeytyso-painiketta.

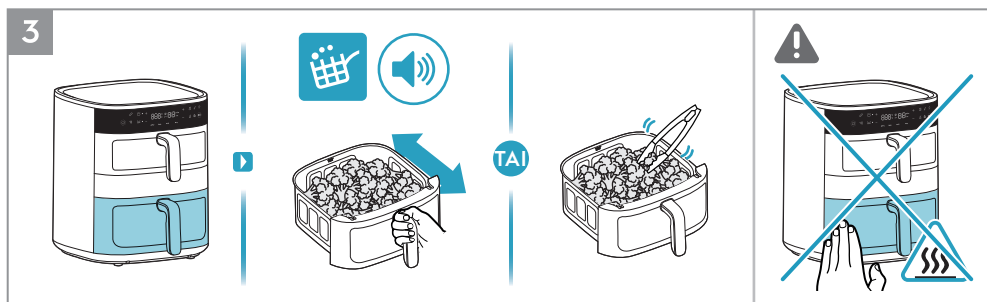

3. Kun "Ravistusmuistutus" -kuvake syttyy ja antaa äänimerkin ruoanlaittoprosessin aikana, käännä ruoka kerran lämmönkestävillä välineillä tai ravista ruoka varovasti hieman paistokorissa.

- ⚠ **VAROITUS:** Älä ravista paistokoria voimakkaasti, jotta ruoka ei roisku ja aiheuta palovammoja.
- ⚠ **VAROITUS:** Ole varovainen kuumien pintojen kanssa, kun laite on käytössä.

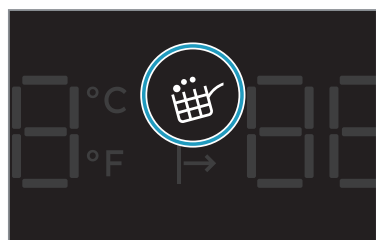

Ravistusmuistutus

"Ravistusmuistutus" aktivoituu Air Fry -toiminnon ja valmiiden reseptien, kuten vihannesten, kalan, kanankoipien ja pihvin, aikana.

Kun on aika ravistaa tai kääntää ruokaa, "Ravistusmuistutus"-kuvake syttyy ja vilkkuu minuutin ajan, samalla kun äänimerkki toistuu kolme kertaa.

"Ravistusmuistutus" ei ole pakollinen, joten ruoanlaitto jatkuu normaalisti, vaikka ruokaa ei käännettäisi tai ravistettaisi.

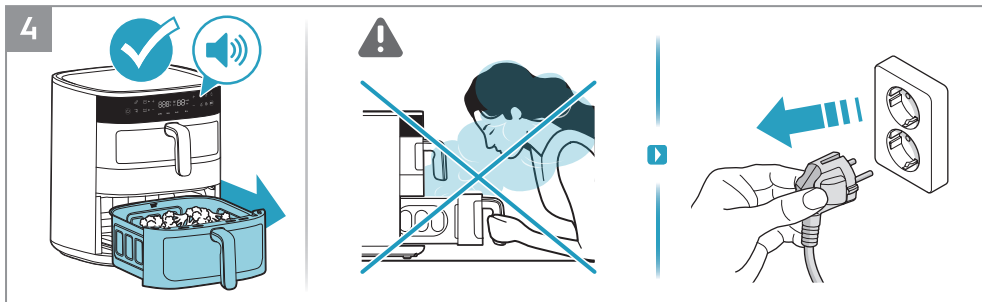

4. Kun kypsennysaika on päättynyt, laite antaa äänimerkin. Poista kori varovasti ja aseta se lämmönkestävälle alustalle. Irrota laite pistorasiasta käytön jälkeen.

⚠ **VAROITUS:** Koriin voi tulla kuumaa höyryä, kun se avataan kypsennyksen keskivaiheilla tai lopussa. Varmista, että kasvossi, käsivartesi ja kätesi ovat kaukana höyrystä, kun avaat sen.

Käyttöohjeet - Ylä- ja alakori

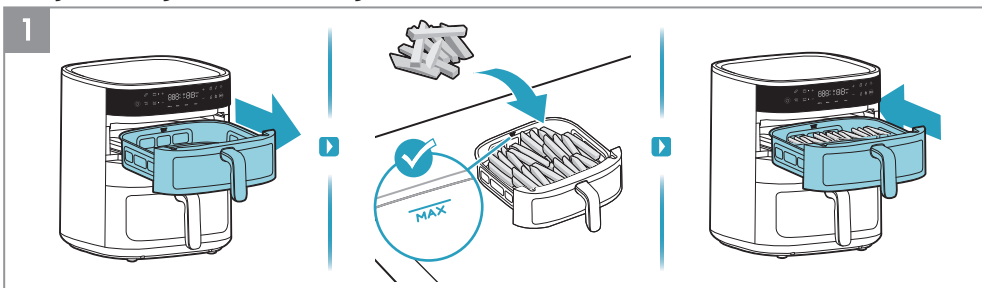

1. Ensinnäkin, vedä yläkori ulos ja laita ruoka koriin, esimerkiksi ranskalaiset perunat

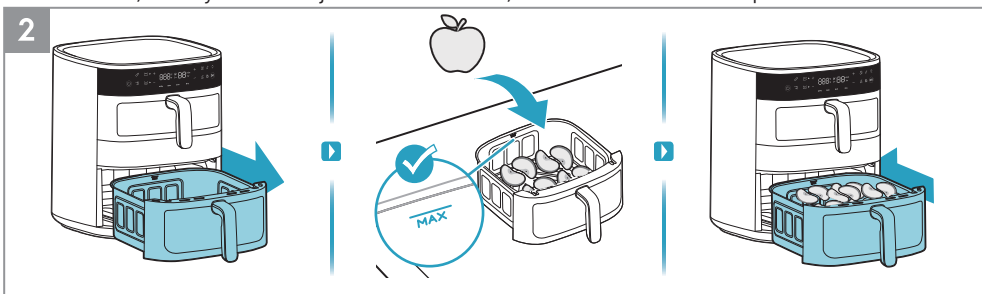

2. Toiseksi, vedä alakori ulos ja laita ruoka koriin, esimerkiksi omenaviipalet



3. Paina virtapainiketta. Valitse ensin yläkori. Valitse sitten haluamasi kypsennysmenetelmä, esimerkiksi Air Fry -toiminto. Säädä aika ja lämpötila makusi mukaan tai valitse yksi valmiista resepteistä, esimerkiksi Vihannekset. Lopuksi paina Toisto/Tauko-painiketta.



4. Toiseksi, valitse alakori. Valitse sitten haluamasi kypsennysmenetelmä, esimerkiksi kuivaustoiminto. Säädä aika ja lämpötila makusi mukaan. Lopuksi paina Toisto/Tauko-painiketta.

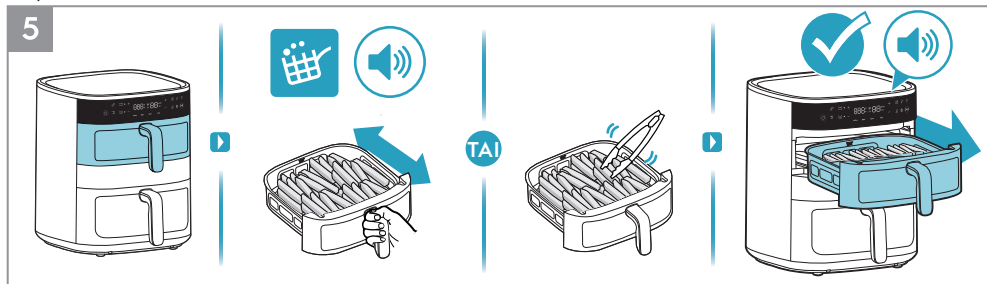

5. Kun "Ravistusmuistutus" -kuvake syttyy ja antaa äänimerkin ruoanlaittoprosessin aikana, käännä ruoka kerran lämmönkestävillä välineillä tai ravista ruoka varovasti hieman paistokorissa. Kun yläkorin kypsennysaika on päättynyt, laite antaa äänimerkin.

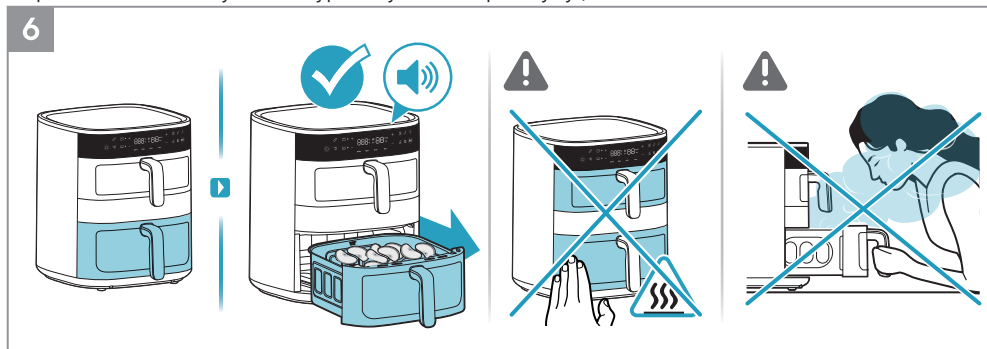

6. Kun alakorin kypsennysaika on päättynyt, laite antaa äänimerkin.

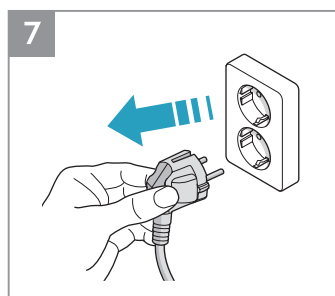

7. Irrota laite pistorasiasta käytön jälkeen.

Käyttöohjeet - Linkkitoiminto

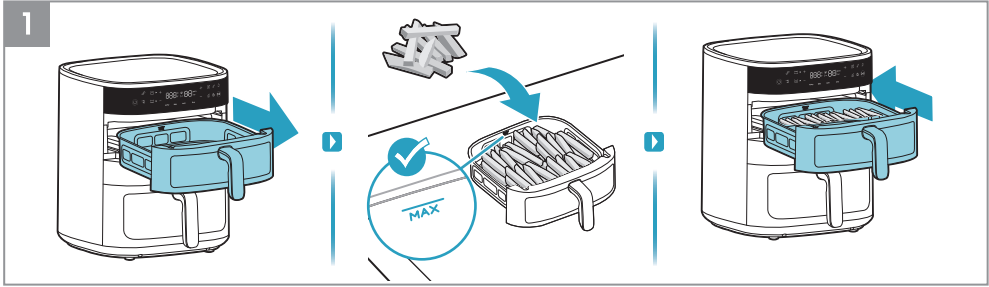

1. Ensinnäkin, vedä yläsäiliö ulos ja laita ruoka säiliöön, esimerkiksi ranskalaiset perunat

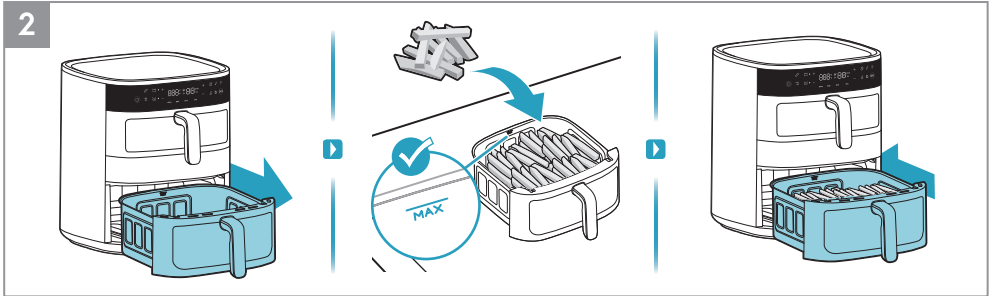

2. Toiseksi, vedä alakori ulos ja laita ruoka koriin, esimerkiksi ranskalaiset perunat



3. Paina virtapainiketta. Valitse ensin linkkitoiminto. Valitse sitten haluamasi kypsennysmenetelmä, esimerkiksi Air Fry -toiminto. Säädä aika ja lämpötila makusi mukaan tai valitse yksi valmiista resepteistä. Lopuksi paina Toisto/Tauko-painiketta.

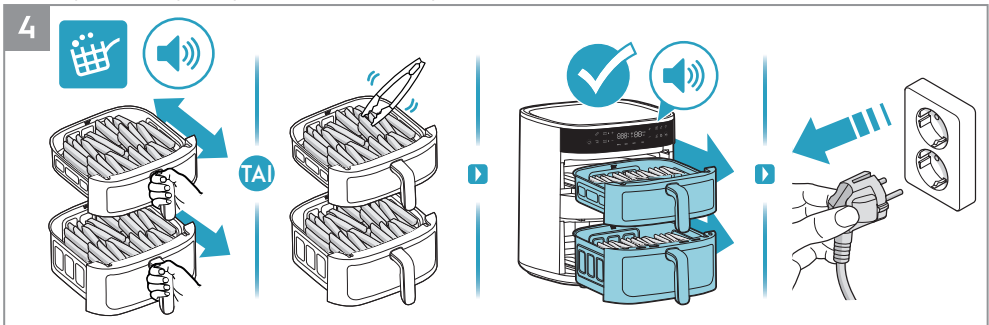

4. Kun "Ravistusmuistutus" -kuvake syttyy ja antaa äänimerkin ruoanlaittoprosessin aikana, käännä ruoka kerran lämmönkestävillä välineillä tai ravista ruoka varovasti hieman paistokorissa. Kun kypsennysaika on päättynyt, laite antaa äänimerkin. Irrota laite pistorasiasta käytön jälkeen.

Käyttöohjeet - Synkronoinnin päättötoiminto

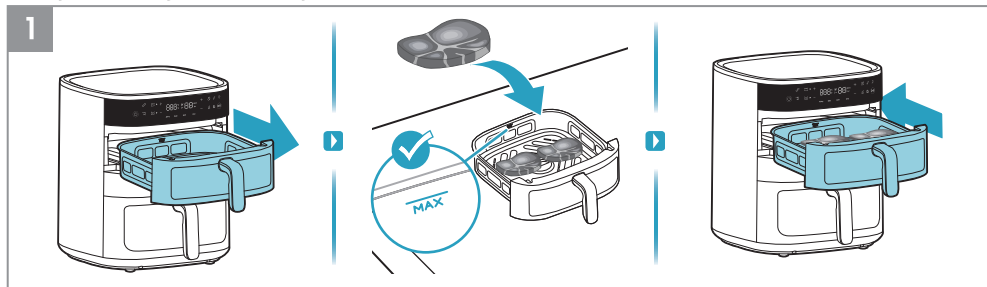

1. Ensinnäkin, vedä yläkori ulos ja laita ruoka koriin, esimerkiksi pihvi.

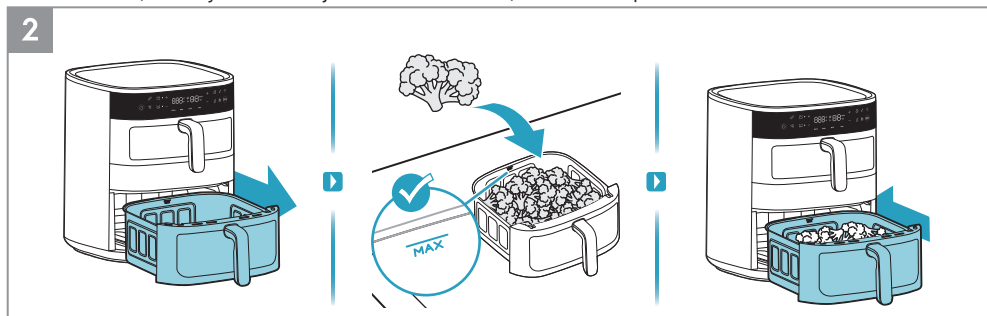

2. Toiseksi, vedä alakori ulos ja laita ruoka koriin, esimerkiksi parsakaali.

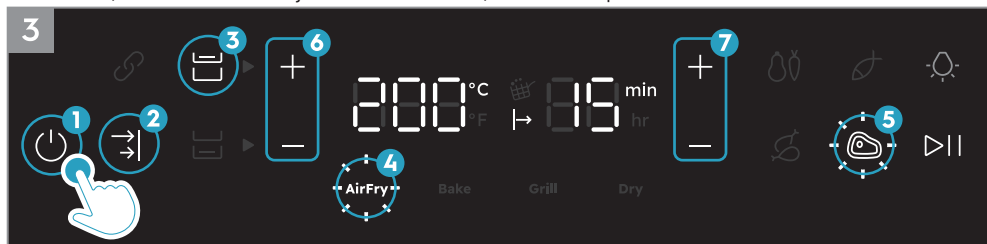

3. Paina Päälle/Pois-painiketta. Valitse Synkronoinnin päättötoiminto. Valitse ensin yläkori ja sitten haluamasi kypsennysmenetelmä, esimerkiksi Air Fry -toiminto. Säädä aika ja lämpötila makusi mukaan tai valitse yksi valmiista resepteistä, esimerkiksi pihvi.



4. Valitse sitten alakori ja haluamasi kypsennysmenetelmä, esimerkiksi Air Fry -toiminto. Säädä aika ja lämpötila makusi mukaan tai valitse yksi valmiista resepteistä. Lopuksi paina Toisto/ Tauko-painiketta.

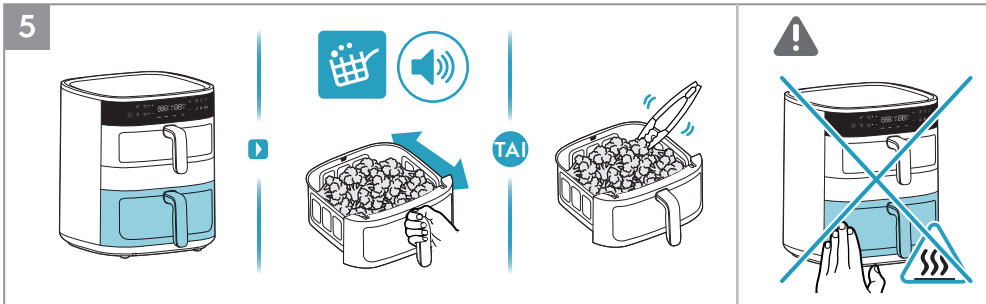

5. Ensinnäkin, alakori, jonka asetusajaka on pidempi, asetetaan etusijalle ruoanlaittoa varten. Kun "Ravistusmuistutus" -kuvake syttyy ja antaa äänimerkin ruoanlaittoprosessin aikana, käännä ruoka kerran lämmönkestävillä välineillä tai ravista ruoka varovasti hieman paistokorissa.

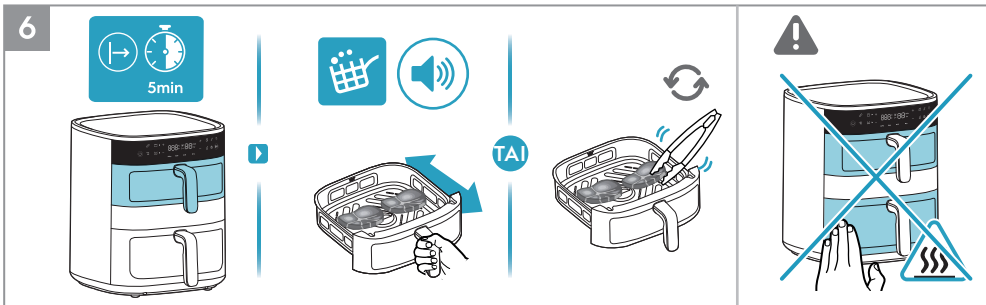

6. Toiseksi, lyhyemmällä asetusajalla varustettu yläkori alkaa kypsentää. Kun "Ravistusmuistutus" -kuvake syttyy ja antaa äänimerkin ruoanlaittoprosessin aikana, käännä ruoka kerran lämmönkestävillä välineillä tai ravista ruoka varovasti hieman paistokorissa.

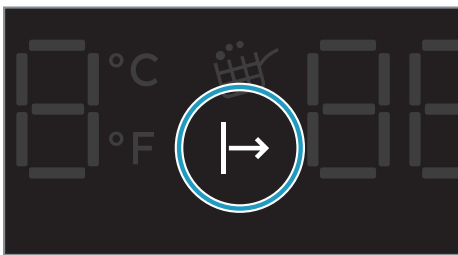

Odottaminen ruoanlaittoon -ilmaisim

Kun "Synkronoinnin päättötoiminto" on aktivoitu, korin, jonka kypsennysaika on lyhyempi, kypsennys odottaa, kunnes korin, jonka kypsennysaika on pidempi, kypsennys on kestänyt jonkin aikaa, jotta molempien korien kypsennys päättyy samaan aikaan. Tänä aikana "Odottaminen ruoanlaittoon -ilmaisim" palaa, kunnes kypsennys alkaa.

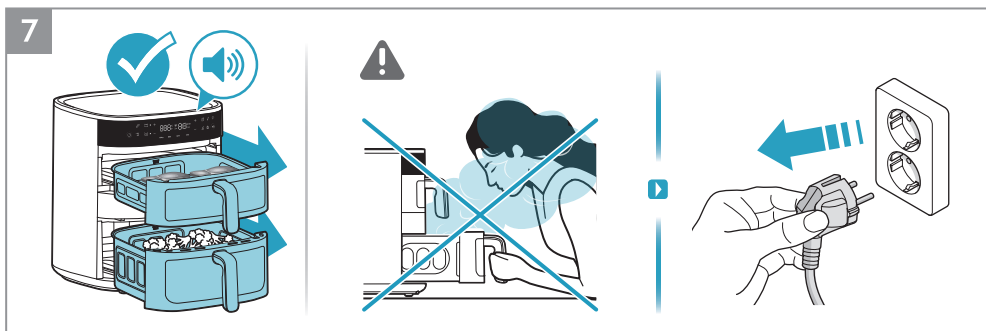

7. Kun kypsennysaika on päättynyt, laite antaa äänimerkin. Irrota laite pistorasiasta käytön jälkeen.

Puhdistus

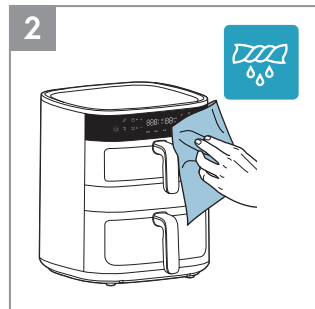
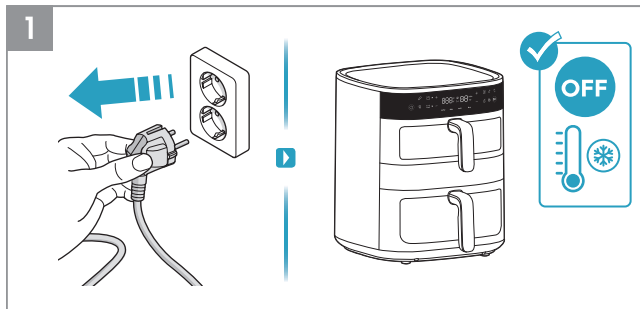

1. Irrota laite aina pistorasiasta ja odota, että se jäähtyy, ennen kuin puhdistat sen.
2. Pyyhi laitteen ulkopinta pehmeällä liinalla.

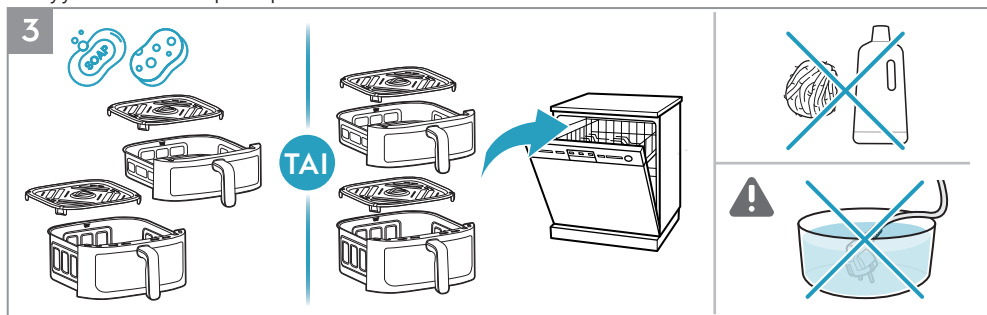

3. Puhdista panna ja ritilä lämpimällä vedellä ja astianpesuaineella tai laita ne astianpesukoneeseen.

▲HUOMAUTUS: Vältä hankaavien puhdistusaineiden tai metallisten työkalujen käyttöä, jotta tarttumaton pinnoite säilyy ehjänä.



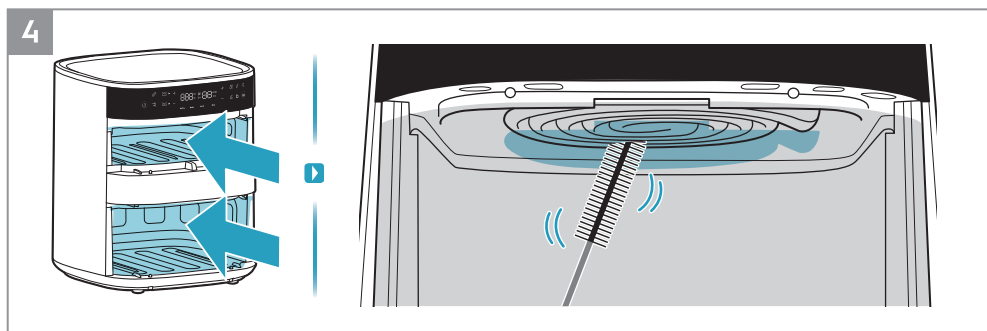









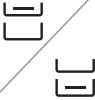

























VAROITUS: Älä koskaan upota tuotetta, sen johtoa tai pistoketta veteen tai muuhun nesteeseen.



4. Puhdista lämmityselementti puhdistusharjalla.











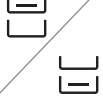











HUOMAUTUS: Varmista, että laite on täysin jäähtynyt ennen lämmityselementin puhdistamista.

Ruoanlaitto-opas

							
AirFry	7mm/10mm 	 4l	400g	180°C	18min		
		 7l	400g	180°C	18min		
AirFry		 4l	400g	170°C	8min		
		 7l	400g	170°C	10min		
AirFry		 4l	400g/2kpl	140°C	15min		
		 7l	400g/2kpl	140°C	15min		
AirFry		 4l	1000g/8kpl	180°C	28min		
		 7l	1000g/8kpl	180°C	28min		
AirFry		 4l	400g/2kpl	200°C	10min		
		 7l	400g/2kpl	200°C	10min		
AirFry		 4l	220g/6tuumaa	160°C	12min		
		 7l	220g/6tuumaa	160°C	14min		

- EN
- BG
- CZ
- DE
- DK
- EE
- FI**
- FR
- GR
- HR
- HU
- IT
- LT
- LV
- NO
- NL
- PL
- PT
- RO
- RU
- SE
- SI
- SK
- SR
- TR
- UA
- ES
- GE
- AL

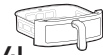
EN
BG
CZ
DE
DK
EE
FI
FR
GR
HR
HU
IT
LT
LV
NO
NL
PL
PT
RO
RU
SE
SI
SK
SR
TR
UA
ES
GE
AL

Recipe							
AirFry		 7l	1200g	180°C	55min		
AirFry		 7l	400g/9kpl	160°C	20min		
Grill		 4l	180g/4kpl	180°C	8min		
		 7l	180g/4kpl	180°C	9min		
Dry		 4l	180g	80°C	3h		
		 7l	180g	80°C	3h		
Dry		 4l	200g	80°C	3h		
		 7l	200g	80°C	3h		

Mitä tehdä, jos...

Ongelma	Tarkista, onko...
Laitetta ei voi aktivoida tai käyttää.	<ul style="list-style-type: none">• Laite on kytketty oikein sähköverkkoon.• Korit ovat oikeassa asennossa. Varmista, että ne on työnnetty kokonaan laitteeseen, jotta virta kytkeytyy päälle.• Kypsennysaika on asetettu.
Koria ei voi työntää laitteeseen.	<ul style="list-style-type: none">• Kori on täytetty yli sen maksimikapasiteetin.• Kori on asetettu oikein. Sen on napsahdettava paikalleen, kun asetat sen laitteeseen.• Korin alla on esine, joka estää sen sulkeutumisen kunnolla.
Laitteesta tulee valkoista savua.	<ul style="list-style-type: none">• Valmistamasi ruoka on liian rasvainen.• Kori, ritilä ja lämmityselementti ovat puhtaat.
Näyttöön tulee E1	<ul style="list-style-type: none">• Yläkorin avoin piiri.
Näyttöön tulee E2	<ul style="list-style-type: none">• Yläkorin oikosulku.
Näyttöön tulee E3	<ul style="list-style-type: none">• Alakorin avoin piiri.
Näyttöön tulee E4	<ul style="list-style-type: none">• Alakorin oikosulku.
Näyttöön tulee E5	<ul style="list-style-type: none">• Ohjaus PCBA-viestinnän vika.
Näyttöön tulee E6	<ul style="list-style-type: none">• Virran PCBA -viestintävirhe.

* Jos näytössä näkyy virhekoodeja, laite on korjattava huoltokeskuksessa.

Tekniset tiedot

Tuote	Air Fryer
Malli	EAFD11B
Jännite (V~)	220 V - 240 V
Teho (W)	2700 W
Taajuus (Hz)	50 ~ 60 Hz
Kapasiteetti	4 L + 7 L



Notice d'utilisation

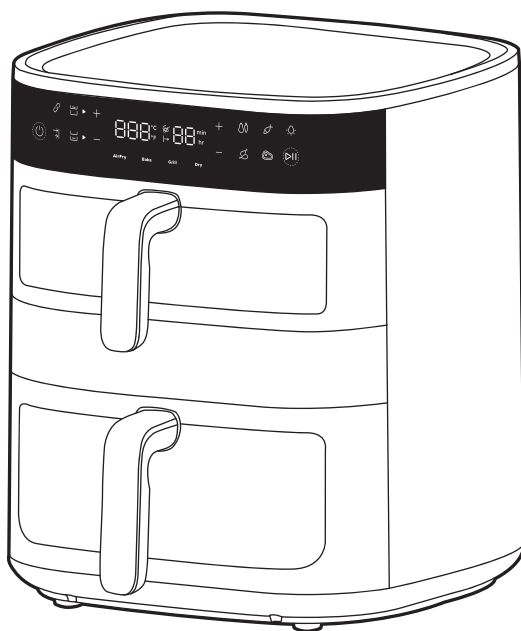

800 Friteuse à l'air chaud double

Présentation générale

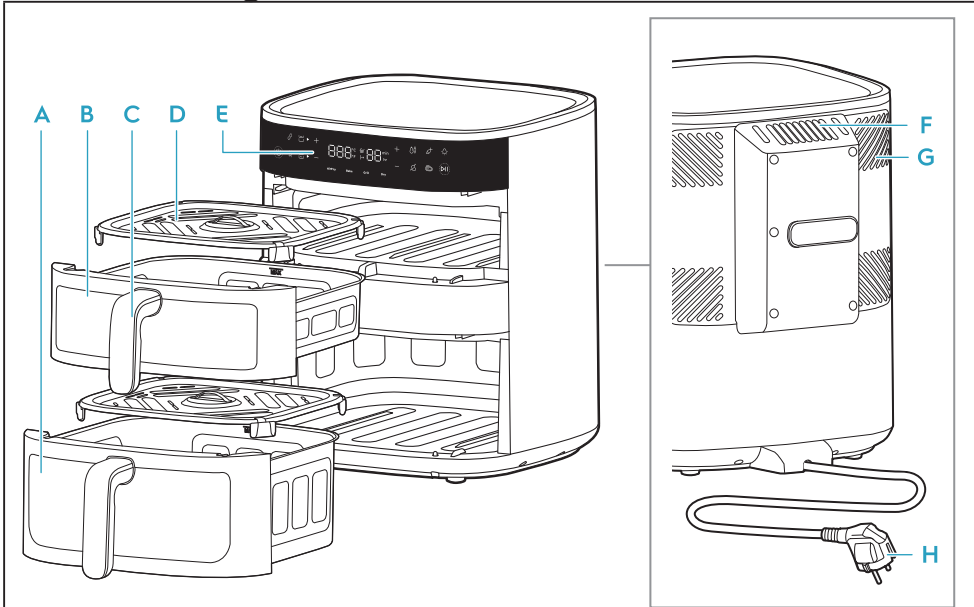

- A** Panier inférieur (7L) **C** Poignée du panier **E** Panneau de commande **G** Système de refroidissement
B Panier supérieur (4L) **D** Grille **F** Sortie d'air **H** Cordon principal

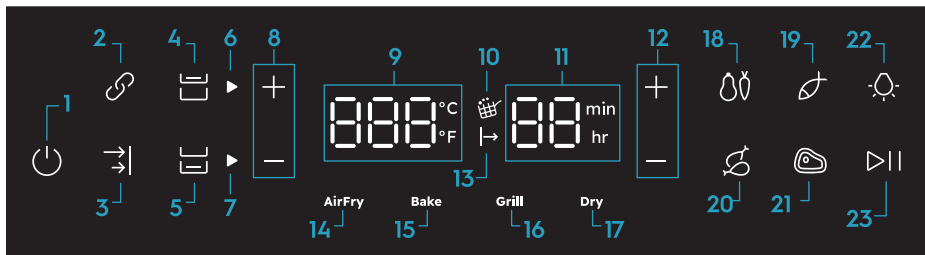

- | | | | |
|---------------------------------------|---|--|--------------------------|
| 1. Activé/Désactivé | 7. Indicateur de panier inférieur | 11. Indicateur du temps (Friture à l'air chaud : 1-99 min, Sécher : 1-5 h) | 16. Fonction grill |
| 2. Fonction de liaison | 8. Contrôle de température | 12. Contrôle du temps | 17. Fonction de séchage |
| 3. Fonction de fin de synchronisation | 9. TIndicateur de température (40-200 °C) | 13. En attente de cuisson | 18. Légumes |
| 4. Contrôle du panier supérieur | 10. Rappel de secouer | 14. Fonction de friture à l'air chaud | 19. Poisson |
| 5. Contrôle du panier inférieur | | 15. Fonction de cuisson au four | 20. Poulets |
| 6. Indicateur de panier supérieur | | | 21. Bifteque |
| | | | 22. Contrôle d'éclairage |
| | | | 23. Lecture/Pause |

Avant la première utilisation

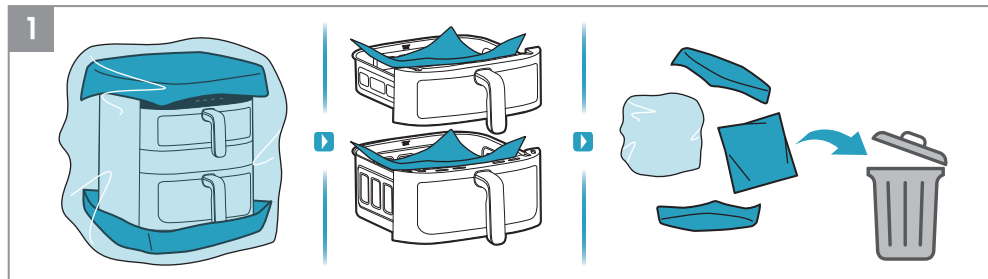

1. Retirez tout l'emballage et le matériel de protection.

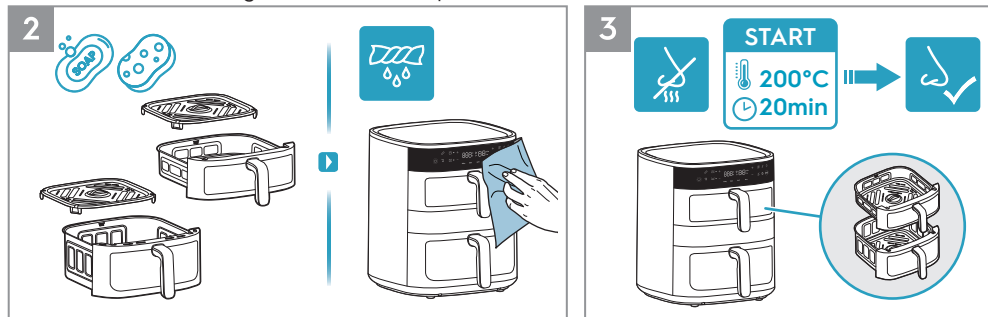

2. Nettoyez la poêle et la grille à l'eau chaude et au liquide vaisselle. Essuyez l'intérieur et l'extérieur de l'appareil avec un chiffon doux.

3. Il est normal qu'un nouvel appareil dégage des odeurs lors des premières utilisations. Pour éviter cela, faites fonctionner la friteuse à l'air chaud vide à 200 °C pendant 20 minutes avant la première utilisation.



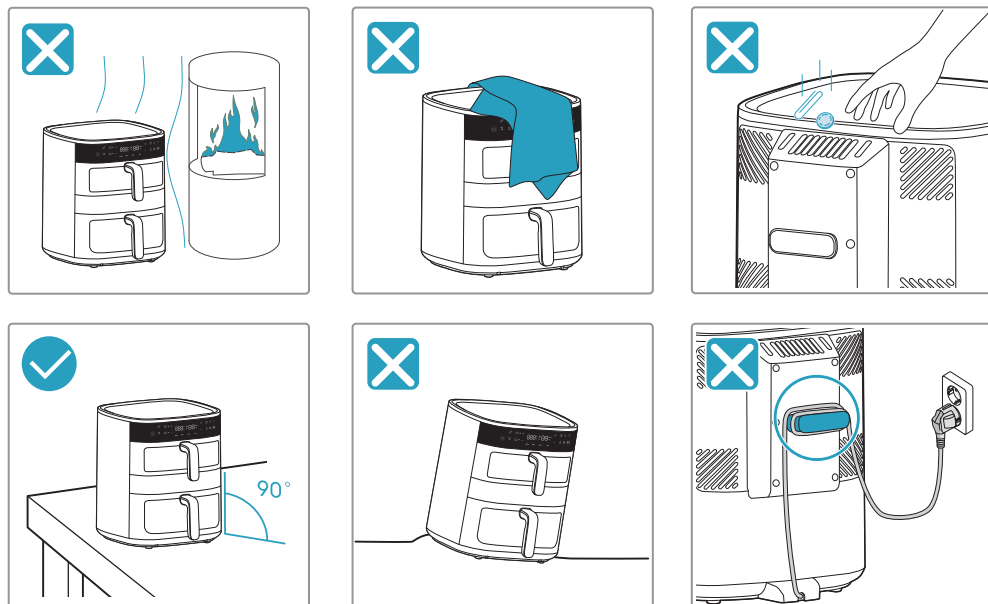



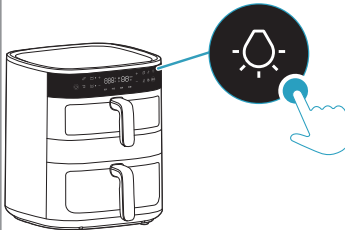
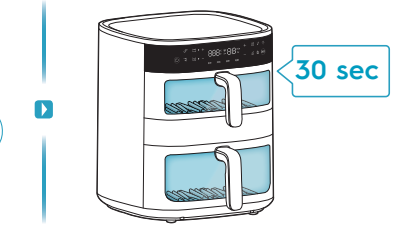
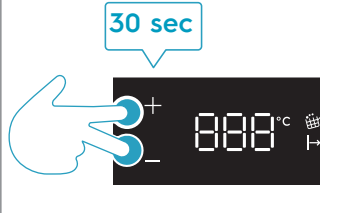
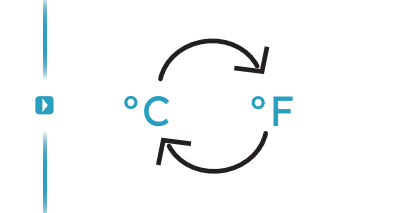





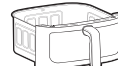

⚠️ Précautions de sécurité









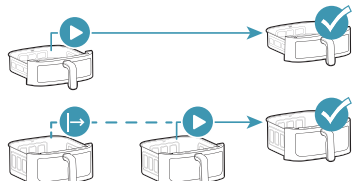



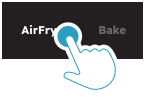



Contrôle de l'éclairage et conversion de l'échelle de température

 <p>Contrôle de l'éclairage</p>		
<p>°C/°F</p> <p>Conversion de l'échelle de température</p>		

Sélection du panier

	 <p>4L</p>	 <p>7L</p>	
 <p>Panier supérieur</p>			
 <p>Panier inférieur</p>			
 <p>Fonction de liaison</p>			
 <p>Fonction de fin de synchronisation</p>			

Fonctions prédéfinies

					
Air Fry	180°C	15min	60-200°C	1-99min	
	170°C	10min	60-200°C	1-99min	
	140°C	15min	60-200°C	1-99min	
	180°C	30min	60-200°C	1-99min	
	200°C	10min	60-200°C	1-99min	
Bake	170°C	15min	60-200°C	1-99min	
Grill	200°C	5min	60-200°C	1-99min	
Dry	80°C	5h	40-80°C	1-5h	

Avant la cuisson

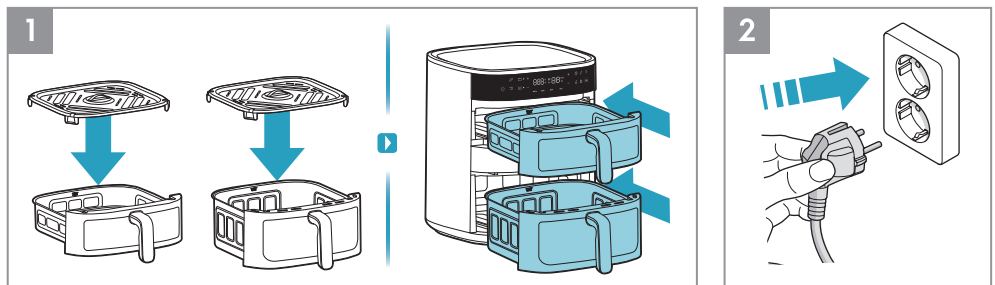

1. Avant chaque cuisson, veuillez placer la grille dans le panier (vous n'avez pas besoin de retirer le coussinet plantaire en silicone résistant à la chaleur de la grille) et enfoncer complètement le panier dans l'appareil.
2. Insérer la fiche dans la prise.

Mode d'emploi - Panier unique

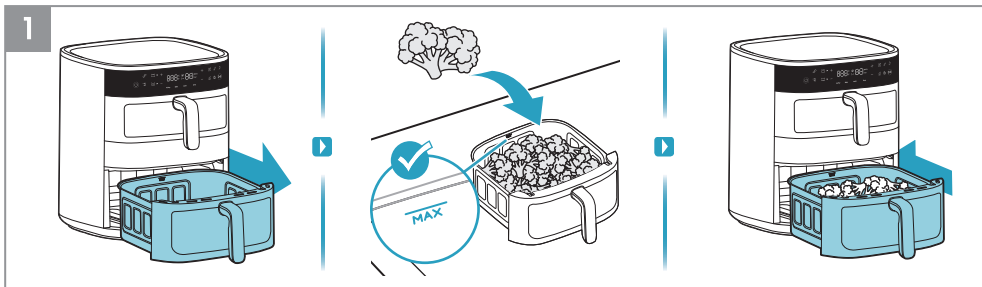

1. Retirez un panier et placez-le sur une surface stable, mettez les aliments dans le panier en respectant l'indication de capacité "MAX.". Ensuite, repoussez complètement le panier contenant les aliments dans l'appareil.

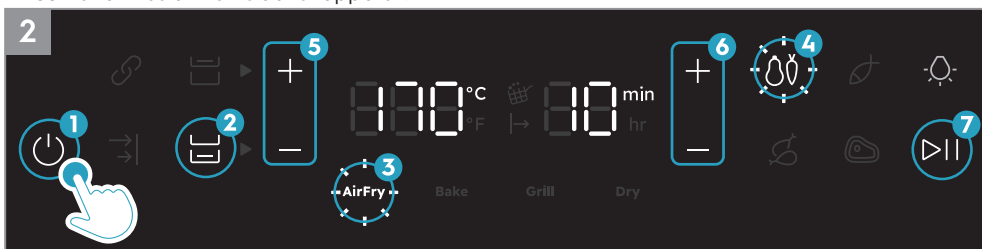

2. Appuyez sur le bouton Activé/Désactivé. Sélectionnez d'abord le panier contenant les aliments. Sélectionnez ensuite le mode de cuisson souhaité, par exemple la fonction de Friture à l'air chaud. Réglez le temps et la température selon vos préférences ou sélectionnez l'une des recettes prédéfinies, par exemple Légumes. Enfin, appuyez sur le bouton Lecture/Pause.

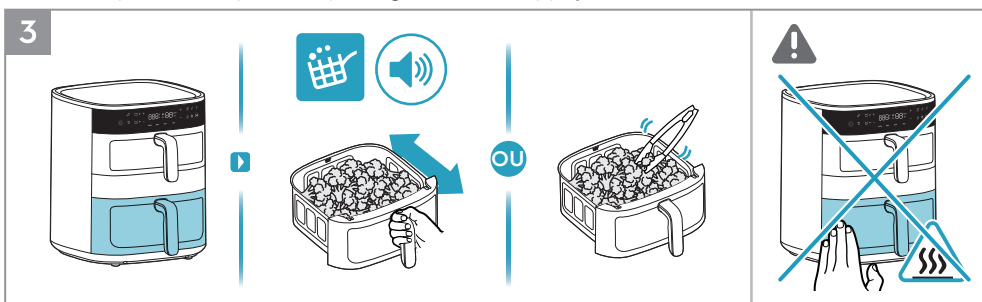

3. Lorsque l'icône " Shake Reminder " (Rappel de secouer) s'allume et émet un bip pendant la cuisson, utilisez des ustensiles résistants à la chaleur pour retourner les aliments une fois ou secouez délicatement les aliments dans le panier de friture.

⚠ **ATTENTION:** Ne secouez pas vigoureusement le panier de friture afin d'éviter les projections d'aliments et les brûlures.

⚠ **ATTENTION:** Faites attention aux surfaces chaudes lorsque l'appareil est en marche.

Rappel de secouer

La fonction " Shake Reminder " (Rappel de secouer) est activée pendant la fonction de Friture à l'air chaud et les recettes prédéfinies, telles que les légumes, le poisson, les cuisses de poulet et le bifteque.

Lorsque le moment est venu de secouer ou de retourner vos aliments, l'icône " Shake Reminder " (Rappel de secouer) s'allume et clignote pendant une minute, tandis qu'un bip retentit trois fois.

Le " Shake Reminder " (Rappel de secouer) n'est pas obligatoire; la cuisson se poursuivra donc normalement même si les aliments ne sont pas retournés ou secoués.

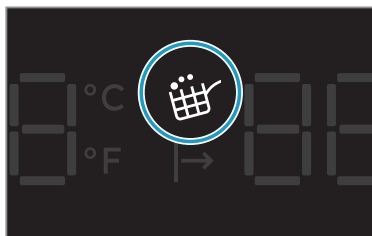



4. À la fin du temps de cuisson, l'appareil émettra un signal sonore. Retirez délicatement le panier et placez-le sur une surface résistante à la chaleur. Débranchez l'appareil après utilisation.

⚠ ATTENTION: De la vapeur chaude peut s'échapper du panier lorsqu'il est ouvert au milieu ou à la fin de la cuisson. Veillez à ce que votre visage, vos bras et vos mains soient éloignés de la vapeur lorsque vous ouvrez le panier.

Mode d'emploi - Panier supérieur + inférieur

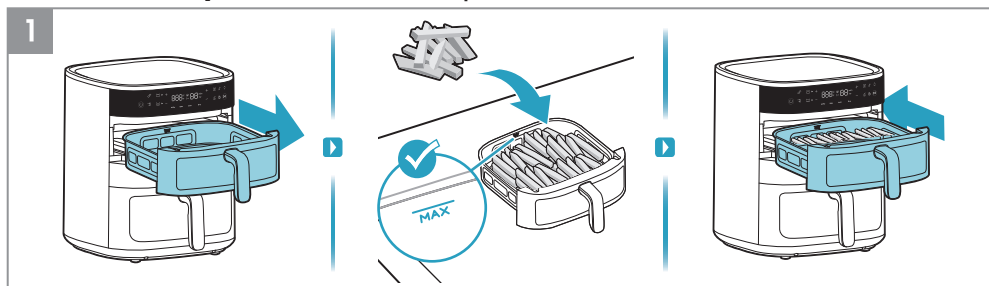

1. Tout d'abord, retirez le panier supérieur et placez les aliments dans le panier, par exemple des frites.

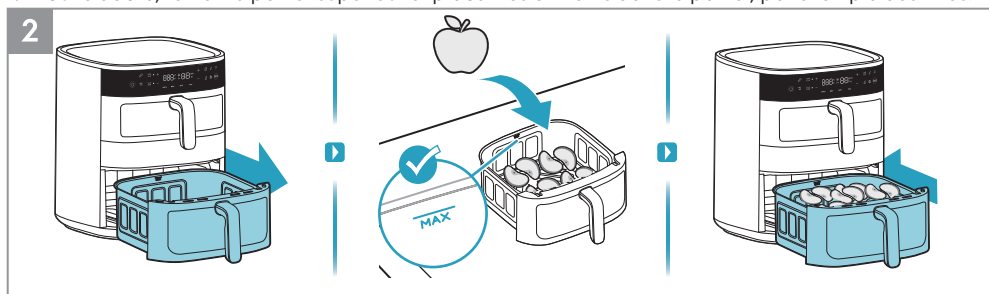

2. Ensuite, retirez le panier inférieur et placez les aliments dans le panier, par exemple des tranches de pomme.



3. Appuyez sur le bouton Activé/Désactivé. Sélectionnez d'abord le panier supérieur. Sélectionnez ensuite le mode de cuisson souhaité, par exemple la fonction de Friture à l'air chaud. Réglez le temps et la température selon vos préférences ou sélectionnez l'une des recettes prédéfinies, par exemple Légumes. Enfin, appuyez sur le bouton Lecture/Pause.



4. Ensuite, sélectionnez le panier inférieur. Sélectionnez ensuite le mode de cuisson souhaité, par exemple la fonction de Séchage. Réglez le temps et la température selon vos préférences. Enfin, appuyez sur le bouton Lecture/Pause.

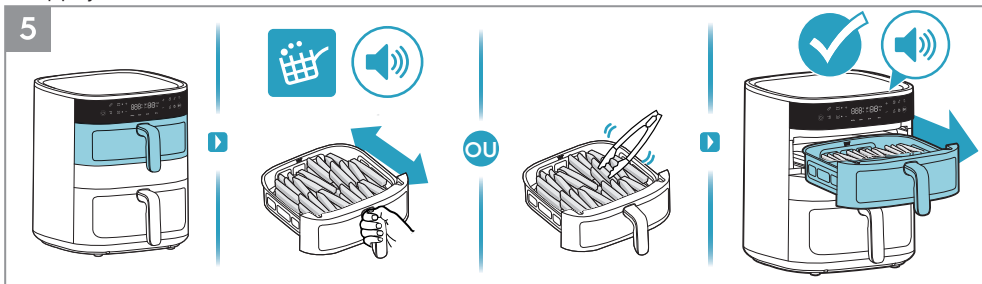

5. Lorsque l'icône "Shake Reminder" (Rappel de secouer) s'allume et émet un bip pendant la cuisson, utilisez des ustensiles résistants à la chaleur pour retourner les aliments une fois ou secouez délicatement les aliments dans à panier de friture. À la fin du temps de cuisson du panier supérieur, l'appareil émettra un signal sonore.

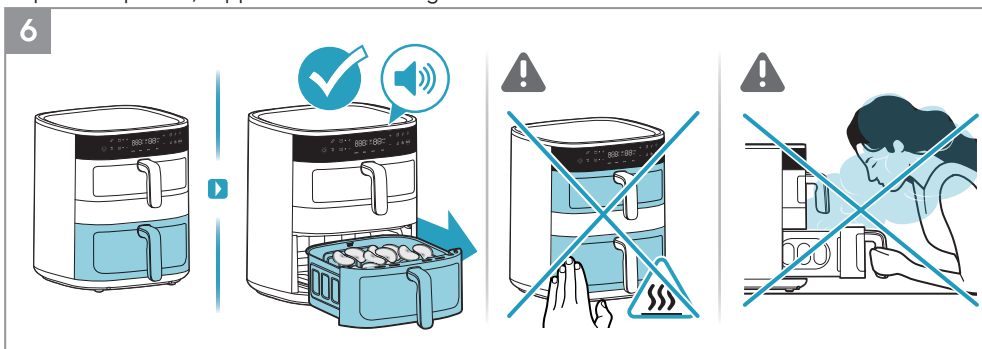

6. À la fin du temps de cuisson du panier inférieur, l'appareil émettra un signal sonore.

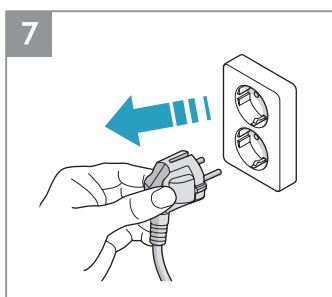

7. Débranchez l'appareil après utilisation.

EN
BG
CZ
DE
DK
EE
FI
FR
GR
HR
HU
IT
LT
LV
NO
NL
PL
PT
RO
RU
SE
SI
SK
SR
TR
UA
ES
GE
AL

Mode d'emploi - Fonction de liaison

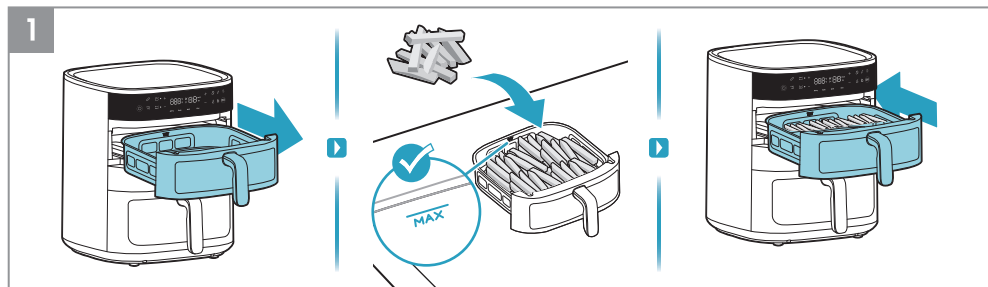

1. Tout d'abord, retirez le panier supérieur et placez les aliments dans le panier, par exemple des frites.

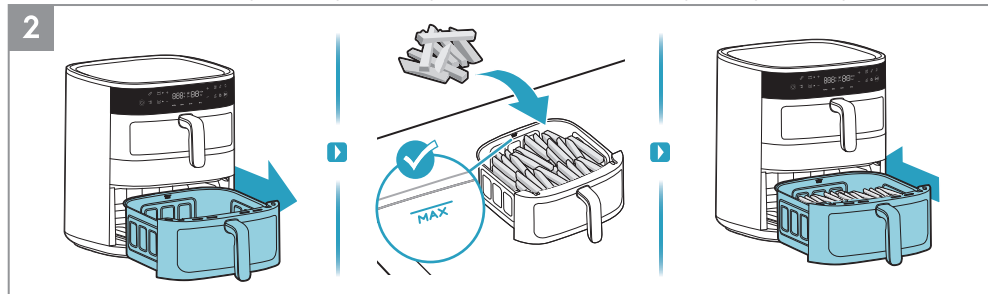

2. Ensuite, retirez le panier inférieur et placez les aliments dans le panier, par exemple des frites.

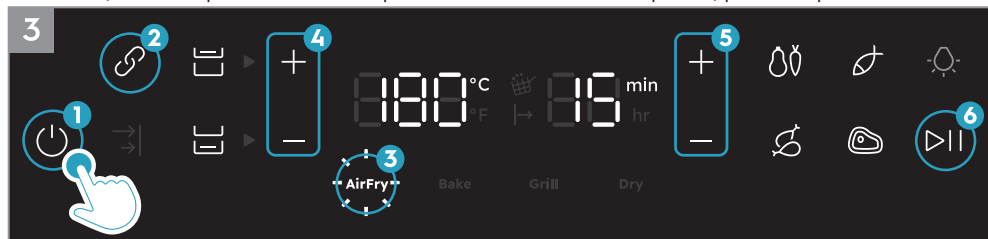

3. Appuyez sur le bouton Activé/Désactivé. Sélectionnez d'abord la fonction de liaison. Sélectionnez ensuite le mode de cuisson souhaité, par exemple la fonction de Friture à l'air chaud. Réglez le temps et la température selon vos préférences ou sélectionnez l'une des recettes prédéfinies. Enfin, appuyez sur le bouton Lecture/Pause.

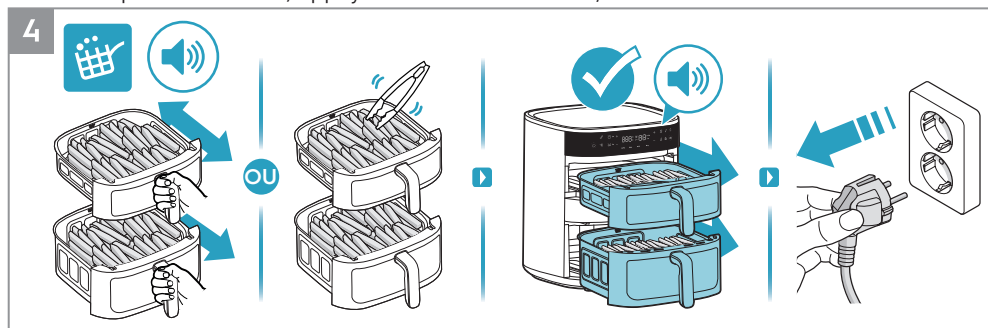

4. Lorsque l'icône "Shake Reminder" (Rappel de secouer) s'allume et émet un bip pendant la cuisson, utilisez des ustensiles résistants à la chaleur pour retourner les aliments une fois ou secouez délicatement les aliments dans le panier de friture. À la fin du temps de cuisson, l'appareil émettra un signal sonore. Débranchez l'appareil après utilisation.

Mode d'emploi - Fonction de fin de synchronisation

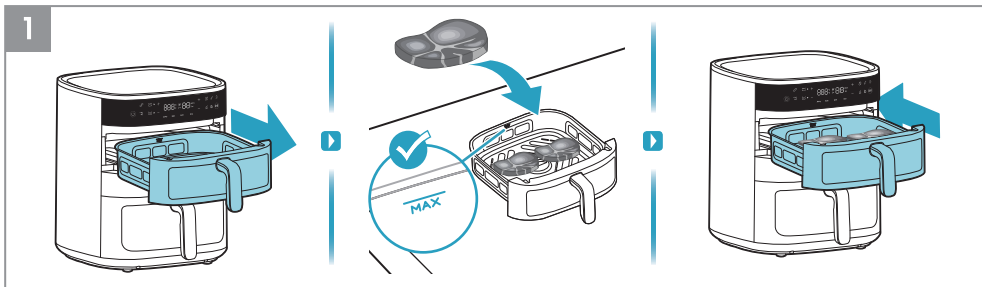

1. Tout d'abord, retirez le panier supérieur et placez les aliments dans le panier, par exemple du bifteque.

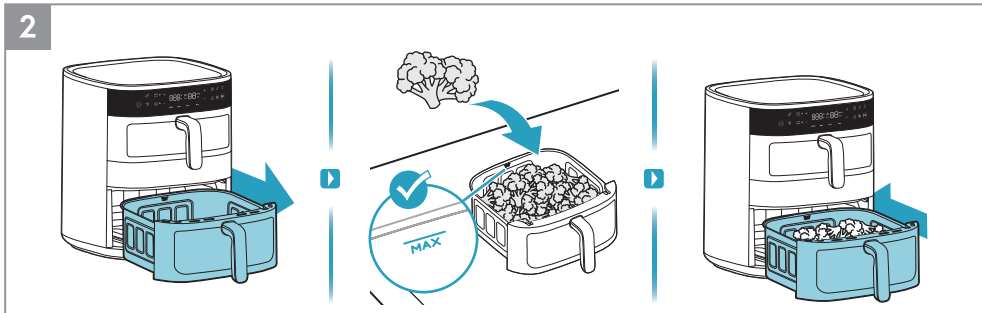

2. Ensuite, retirez le panier inférieur et placez les aliments dans le panier, par exemple du brocoli.



3. Appuyez sur le bouton Activé/Désactivé. Sélectionnez la fonction de fin de synchronisation. Sélectionnez d'abord le panier supérieur, puis choisissez le mode de cuisson souhaité, par exemple la fonction de Friture à l'air chaud. Réglez le temps et la température selon vos préférences ou sélectionnez l'une des recettes prédéfinies, par exemple Bifteque.



4. Sélectionnez ensuite le panier inférieur, puis choisissez le mode de cuisson souhaité, par exemple la fonction de Friture à l'air chaud. Réglez le temps et la température selon vos préférences ou sélectionnez l'une des recettes prédéfinies. Enfin, appuyez sur le bouton Lecture/Pause.

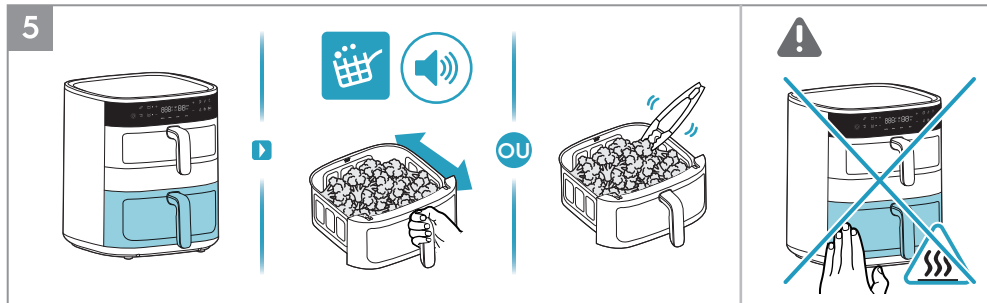

5. Tout d'abord, le panier avec un temps de cuisson plus long sera prioritaire pour la cuisson. Lorsque l'icône "Shake Reminder" (Rappel de secouer) s'allume et émet un bip pendant la cuisson, utilisez des ustensiles résistants à la chaleur pour retourner les aliments une fois ou secouez délicatement les aliments dans à panier de friture.

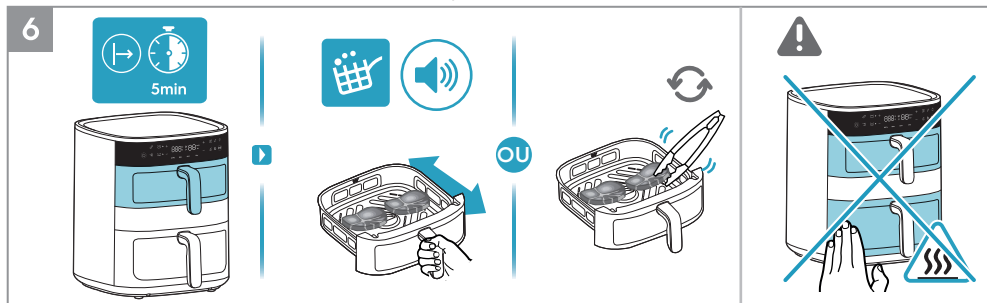

6. Ensuite, le panier supérieur avec un temps de cuisson plus court commencera la cuisson. Lorsque l'icône "Shake Reminder" (Rappel de secouer) s'allume et émet un bip pendant la cuisson, utilisez des ustensiles résistants à la chaleur pour retourner les aliments une fois ou secouez délicatement les aliments dans à panier de friture.

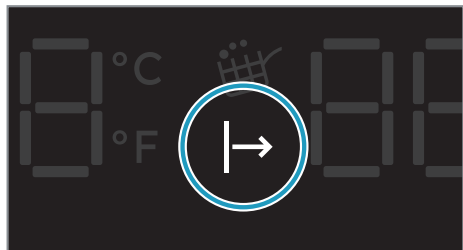

Voyant "En attente de cuisson"

Lorsque la fonction de fin de synchronisation est activée, le panier dont le temps de cuisson est plus court attendra d'abord que le panier dont le temps de cuisson est plus long ait cuit pendant un certain temps, afin que les deux paniers puissent terminer leur cuisson en même temps. Pendant cette période, le voyant "en attente de cuisson" restera allumé jusqu'au début de la cuisson.

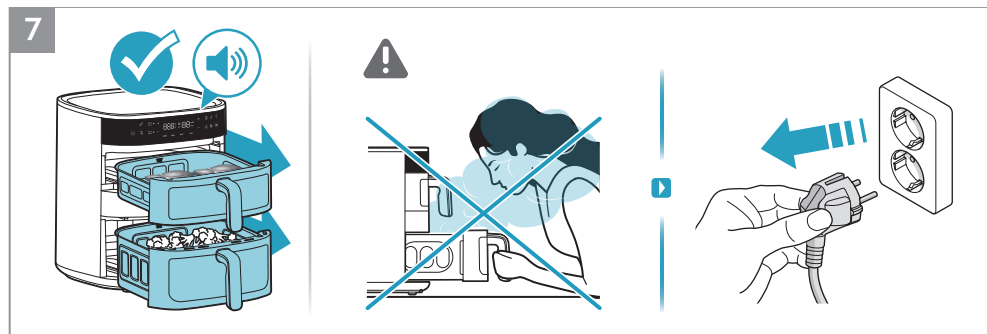

7. À la fin du temps de cuisson, l'appareil émettra un signal sonore. Débranchez l'appareil après utilisation.

Nettoyage

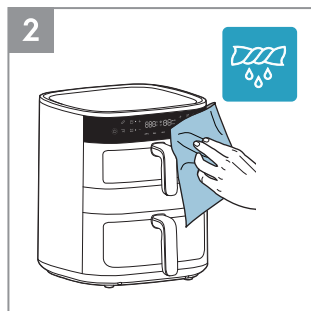
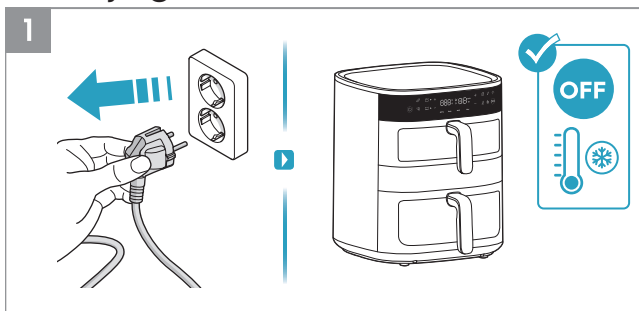

1. Débranchez toujours l'appareil et attendez qu'il refroidisse avant de le nettoyer.
2. Essuyez l'extérieur de l'appareil avec un chiffon doux.

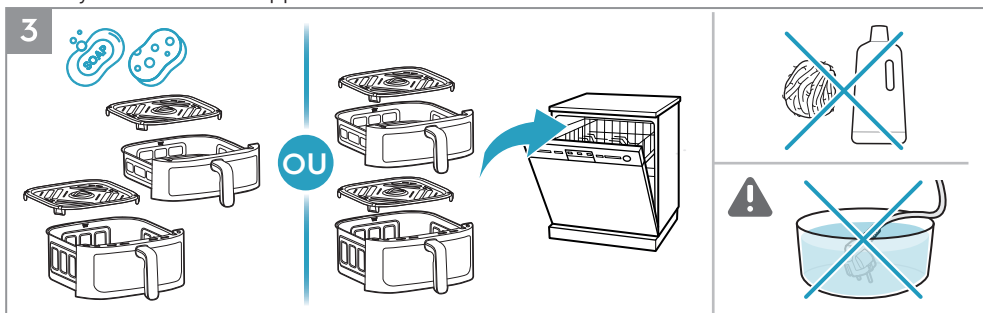

3. Nettoyez la poêle et la grille à l'eau chaude et au liquide vaisselle, ou mettez-les dans le lave-vaisselle.

REMARQUE: Évitez d'utiliser des produits nettoyants abrasifs ou des outils métalliques afin de protéger le revêtement antiadhésif.

ATTENTION: Ne plongez jamais le produit, son cordon ou sa prise dans l'eau ou dans un autre liquide.

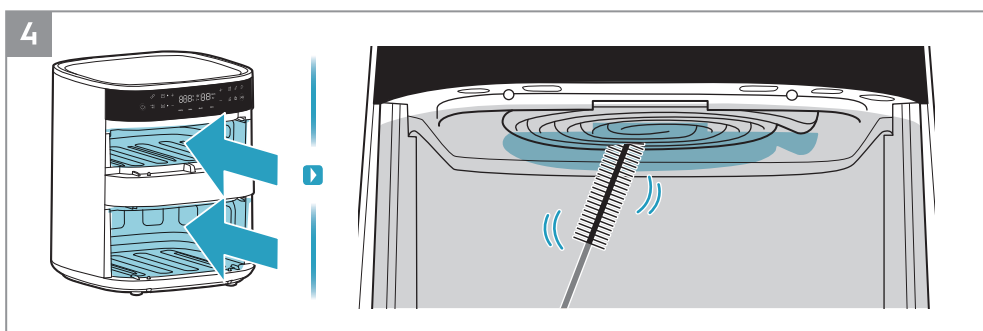











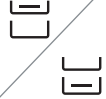

















































4. Nettoyez l'élément chauffant à l'aide d'une brosse de nettoyage.

REMARQUE: Assurez-vous que l'appareil est complètement refroidi avant de nettoyer l'élément chauffant.

EN
BG
CZ
DE
DK
EE
FI
FR
GR
HR
HU
IT
LT
LV
NO
NL
PL
PT
RO
RU
SE
SI
SK
SR
TR
UA
ES
GE
AL

Guide de cuisson

							
AirFry	7mm/10mm 	4L 	400g	180°C	18min		
		7L 	400g	180°C	18min		
AirFry		4L 	400g	170°C	8min		
		7L 	400g	170°C	10min		
AirFry		4L 	400g/2pièces	140°C	15min		
		7L 	400g/2pièces	140°C	15min		
AirFry		4L 	1000g/8pièces	180°C	28min		
		7L 	1000g/8pièces	180°C	28min		
AirFry		4L 	400g/2pièces	200°C	10min		
		7L 	400g/2pièces	200°C	10min		
AirFry		4L 	220g/6pouces	160°C	12min		
		7L 	220g/6pouces	160°C	14min		

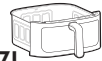
							
AirFry		 7L	1200g	180°C	55min		
AirFry		 7L	400g/9pièces	160°C	20min		
Grill		 4L	180g/4pièces	180°C	8min		
		 7L	180g/4pièces	180°C	9min		
Dry		 4L	180g	80°C	3h		
		 7L	180g	80°C	3h		
Dry		 4L	200g	80°C	3h		
		 7L	200g	80°C	3h		

- EN
- BG
- CZ
- DE
- DK
- EE
- FI
- FR**
- GR
- HR
- HU
- IT
- LT
- LV
- NO
- NL
- PL
- PT
- RO
- RU
- SE
- SI
- SK
- SR
- TR
- UA
- ES
- GE
- AL

Que faire si...

Problème	Vérifier si...
Vous ne pouvez pas activer ou faire fonctionner l'appareil.	<ul style="list-style-type: none"> • L'appareil est correctement connecté à une source d'alimentation électrique. • Les paniers sont dans la bonne position. Assurez-vous qu'ils sont complètement introduits dans l'appareil afin de permettre l'alimentation électrique. • Le temps de cuisson est défini.
Vous ne pouvez pas introduire le panier dans l'appareil.	<ul style="list-style-type: none"> • Le panier est rempli à sa capacité maximale. • Le panier est correctement inséré. Il doit faire un bruit sec lorsque vous l'insérez dans l'appareil. • Un objet se trouve sous le panier, et il l'empêche de se fermer normalement
De la fumée blanche s'échappe de l'appareil.	<ul style="list-style-type: none"> • La nourriture que vous avez préparée est trop grasse. • Le panier, la grille et l'élément chauffant sont propres.
L'écran affiche E1.	• Circuit ouvert du panier supérieur.
L'écran affiche E2.	• Court-circuit du panier supérieur.
L'écran affiche E3.	• Circuit ouvert du panier inférieur.
L'écran affiche E4.	• Court-circuit du panier inférieur.
L'écran affiche E5.	• Échec de communication de l'assemblage de circuits imprimés de contrôle.
L'écran affiche E6.	• Échec de communication de l'assemblage de circuits imprimés d'alimentation.

* Si l'écran affiche des codes d'erreur, l'appareil doit être réparé par un centre de service.

Données techniques

Produit	Friteuse à l'air
Modèle	EAFD11B
Tension (V~)	220 V - 240 V
Puissance (W)	2700 W
Fréquence (Hz)	50 - 60 Hz
Capacité	4 L + 7 L



Εγχειρίδιο οδηγιών

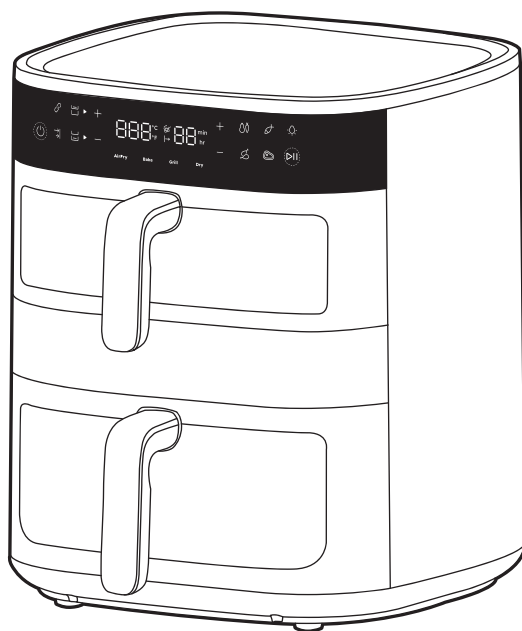

800 Διπλή φριτέζα αέρος

Γενική επισκόπηση

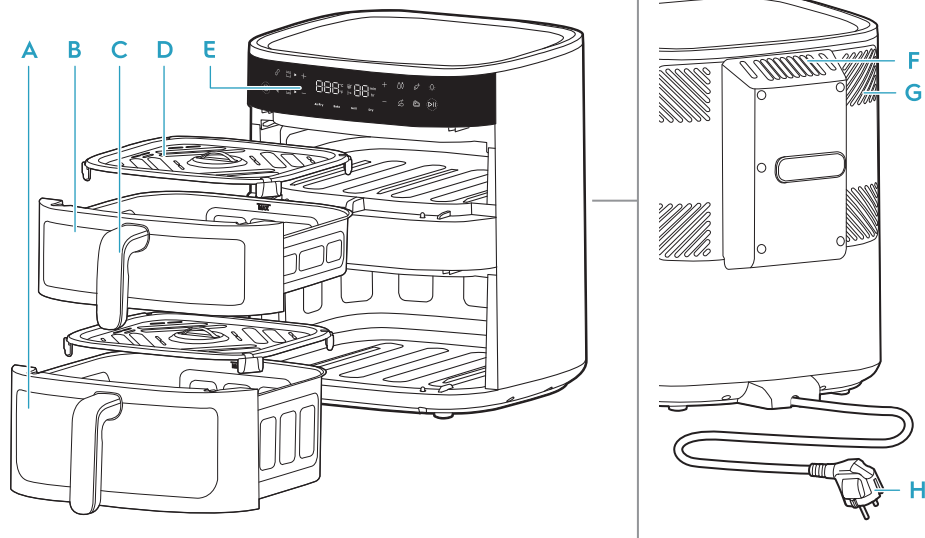

- A** Κάτω καλάθι (7 λίτρων) **C** Λαβή καλαθιού **E** Πίνακας ελέγχου **G** Σύστημα μείωσης θερμότητας
B Πάνω καλάθι (4 λίτρων) **D** Σχάρα **F** Έξοδος αέρα **H** Κύριο καλώδιο

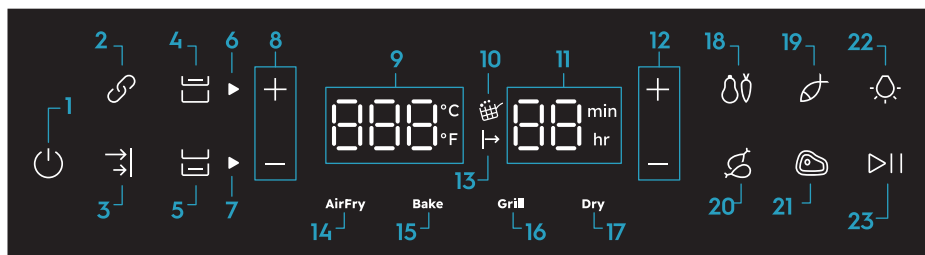

- | | | | |
|--|---|------------------------------------|----------------------------|
| 1. Ενεργοποίηση/Απενεργοποίηση | 8. Έλεγχος θερμοκρασίας | ώρες) | 17. Λειτουργία αποξήρανσης |
| 2. Λειτουργία σύνδεσης | 9. Ένδειξη θερμοκρασίας (40-200°C) | 12. Έλεγχος χρόνου | 18. Λαχανικά |
| 3. Λειτουργία συγχρονισμού ολοκλήρωσης | 10. Υπενθύμιση ανακίνησης | 13. Αναμονή για μαγείρεμα | 19. Ψάρι |
| 4. Έλεγχος πάνω καλαθιού | 11. Ένδειξη χρόνου (Ψήσιμο στον αέρα: 1-99 λεπτά, Αποξήρανση: 1-5 | 14. Λειτουργία ψησίματος στον αέρα | 20. Κοτόπουλο |
| 5. Έλεγχος κάτω καλαθιού | ώρες) | 15. Λειτουργία ψησίματος | 21. Μπριζόλα |
| 6. Ένδειξη πάνω καλαθιού | | 16. Λειτουργία γκριλ | 22. Έλεγχος φωτισμού |
| 7. Ένδειξη κάτω καλαθιού | | | 23. Αναπαραγωγή/Παύση |

Πριν από την πρώτη χρήση

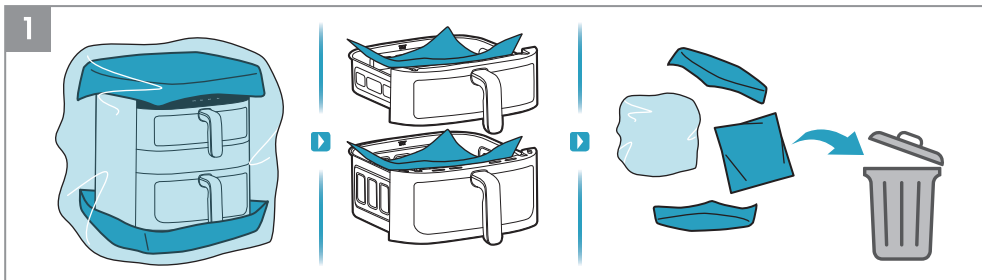

1. Αφαιρέστε όλα τα υλικά συσκευασίας και τα προστατευτικά υλικά.

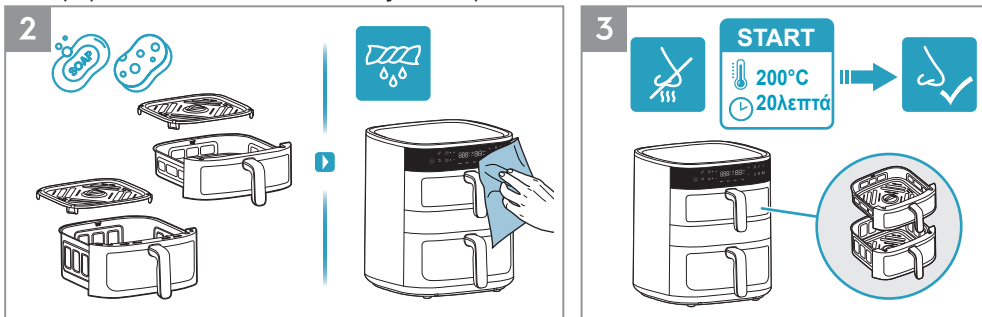

2. Καθαρίστε το ταψί και τη σχάρα με ζεστό νερό και σαπούνι για πιάτα. Σκουπίστε το εσωτερικό και το εξωτερικό της συσκευής με ένα μαλακό πανί.

3. Είναι φυσιολογικό να υπάρχει οσμή από μια νέα συσκευή τις πρώτες φορές χρήσης. Λειτουργήστε την άδεια φριτέζα αέρος στους 200°C για 20 λεπτά πριν από την πρώτη χρήση, για να το αποφύγετε αυτό.

! Προφυλάξεις ασφαλείας

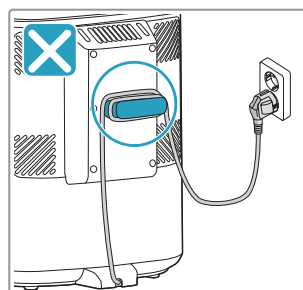
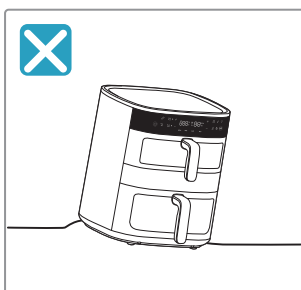
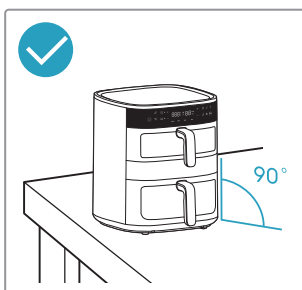
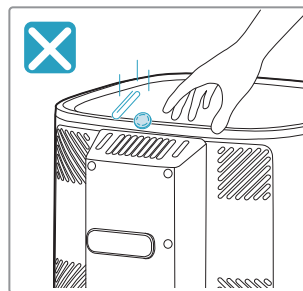
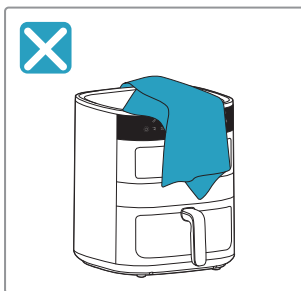
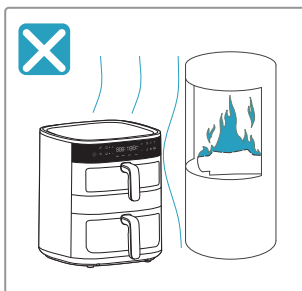





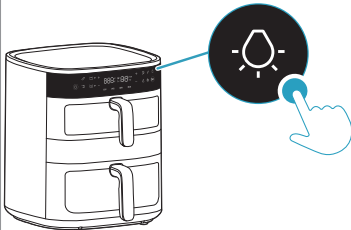
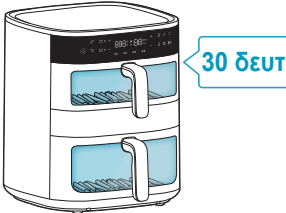
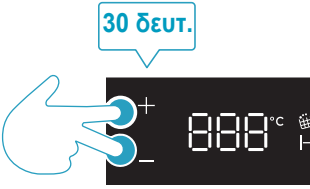
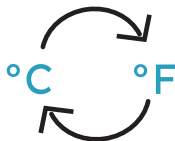









EN
BG
CZ
DE
DK
EE
FI
FR
GR
HR
HU
IT
LT
LV
NO
NL
PL
PT
RO
RU
SE
SI
SK
SR
TR
UA
ES
GE
AL







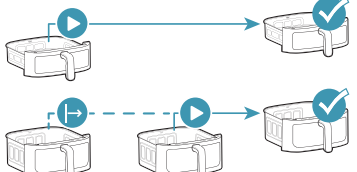







Έλεγχος φωτισμού και μετατροπή κλίμακας θερμοκρασίας

 <p>Έλεγχος φωτισμού</p>		
<p>°C/°F</p> <p>Μετατροπή κλίμακας θερμοκρασίας</p>		

Επιλογή καλαθιού

	 <p>4L</p>	 <p>7L</p>	
 <p>Πάνω καλάθι</p>			
 <p>Κάτω καλάθι</p>			
 <p>Λειτουργία σύνδεσης</p>			
 <p>Λειτουργία συγχρονισμού ολοκλήρωσης</p>			

Προκαθορισμένες λειτουργίες

					
Air Fry	180°C	15λεπτά	60~200°C	1~99λεπτά	
	170°C	10λεπτά	60~200°C	1~99λεπτά	
	140°C	15λεπτά	60~200°C	1~99λεπτά	
	180°C	30λεπτά	60~200°C	1~99λεπτά	
	200°C	10λεπτά	60~200°C	1~99λεπτά	
Bake	170°C	15λεπτά	60~200°C	1~99λεπτά	
Grill	200°C	5λεπτά	60~200°C	1~99λεπτά	
Dry	80°C	5ώρες	40~80°C	1~5ώρες	

Πριν από το μαγείρεμα

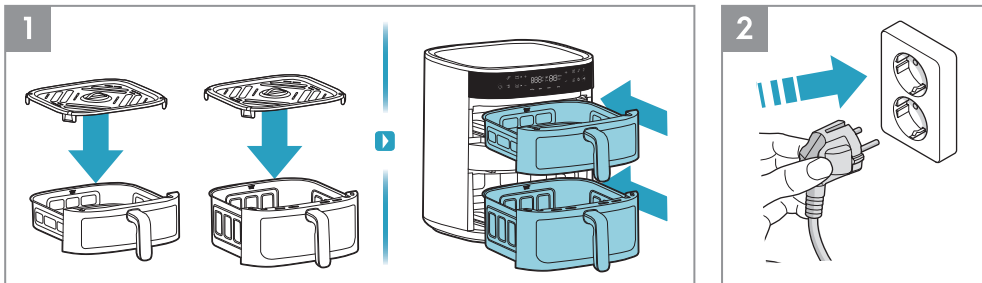

1. Πριν από κάθε μαγείρεμα, τοποθετήστε τη σχάρα μέσα στο καλάθι (το ανθεκτικό στη θερμότητα σιλικονούχο πέλημα στη σχάρα δεν χρειάζεται να αφαιρεθεί) και σπρώξτε τελείως το καλάθι μέσα στη συσκευή.
2. Εισαγάγετε το φις τροφοδοσίας στην ηλεκτρική πρίζα.

Τρόπος χρήσης - Μονό καλάθι

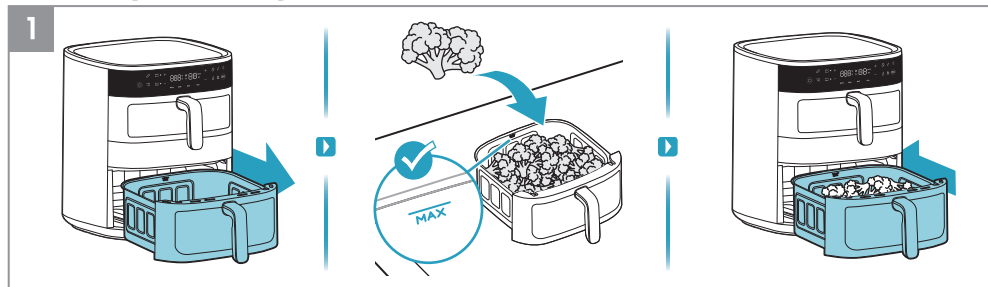

1. Τραβήξτε έξω ένα καλάθι, τοποθετήστε το σε μια σταθερή επιφάνεια και τοποθετήστε τα τρόφιμα στο καλάθι μέχρι το επίπεδο της ένδειξης πλήρωσης "MAX". Έπειτα σπρώξτε το καλάθι με τα τρόφιμα τελείως μέσα στη συσκευή.

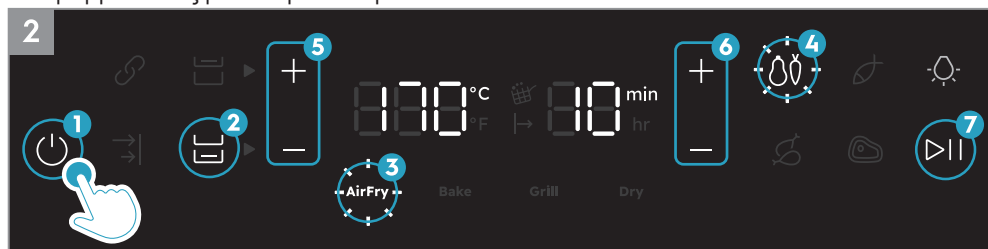

2. Πατήστε το κουμπί Ενεργοποίηση/Απενεργοποίηση. Πρώτα επιλέξτε το καλάθι με τα τρόφιμα. Έπειτα επιλέξτε την επιθυμητή μέθοδο μαγειρέματος, για παράδειγμα τη λειτουργία ψησίματος στον αέρα. Ρυθμίστε τον χρόνο και τη θερμοκρασία σύμφωνα με τις προτιμήσεις σας ή επιλέξτε μία από τις προκαθορισμένες συνταγές, για παράδειγμα Λαχανικά. Τέλος, πατήστε το κουμπί Αναπαραγωγή/Παύση.

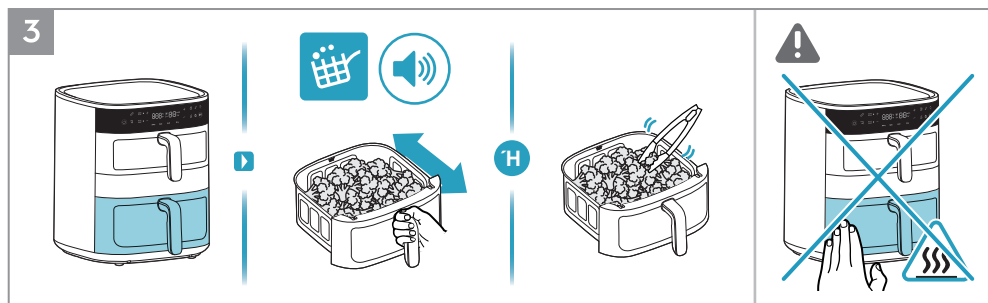

3. Όταν το εικονίδιο "Υπενθύμιση ανακίνησης" ανάβει και ακούγεται ένας ήχος κατά τη διαδικασία του μαγειρέματος, χρησιμοποιήστε εργαλεία ανθεκτικά στη θερμότητα για να γυρίσετε τα τρόφιμα μία φορά ή ανακινήστε προσεκτικά τα τρόφιμα ελαφρώς στο καλάθι ψησίματος.

⚠ **ΠΡΟΣΟΧΗ:** Μην ανακινείτε το καλάθι ψησίματος δυνατά, για να μη πιτσιλιστούν τρόφιμα και προκληθούν εγκαύματα.

⚠ **ΠΡΟΣΟΧΗ:** Να είστε προσεκτικοί με τις καυτές επιφάνειες όταν χρησιμοποιείται η συσκευή.

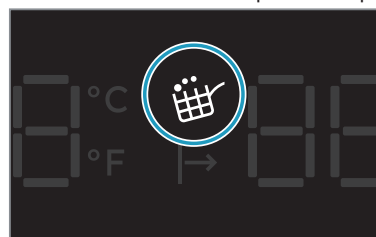

Υπενθύμιση ανακίνησης

Η "Υπενθύμιση ανακίνησης" ενεργοποιείται κατά τη λειτουργία ψησίματος στον αέρα και τις προκαθορισμένες συνταγές, όπως λαχανικά, ψάρι, μπουτία κοτόπουλου και μπριζόλα.

Όταν έρθει η στιγμή να ανακινήσετε ή να γυρίσετε τα τρόφιμά σας, το εικονίδιο "Υπενθύμιση ανακίνησης" θα ανάψει και θα αναβοσβήνει για ένα λεπτό, ενώ ένας χαρακτηριστικός ήχος θα επαναληφθεί τρεις φορές. Η "Υπενθύμιση ανακίνησης" δεν είναι υποχρεωτική, επομένως το μαγείρεμα θα συνεχιστεί κανονικά, ακόμη και αν δεν ανακινήσετε ή γυρίσετε το φαγητό.



4. Στο τέλος του χρόνου μαγειρέματος, θα ακουστεί ένας χαρακτηριστικός ήχος από τη συσκευή. Αφαιρέστε προσεκτικά το καλάθι και τοποθετήστε το σε μια επιφάνεια ανθεκτική στη θερμότητα. Βγάλτε το φινις της συσκευής από την πρίζα μετά τη χρήση.

⚠ **ΠΡΟΣΟΧΗ:** Μπορεί να βγει καυτός ατμός από το καλάθι όταν ανοίγετε τη συσκευή στη μέση ή στο τέλος του μαγειρέματος. Βεβαιωθείτε ότι το πρόσωπο, τα μπράτσα και τα χέρια σας είναι μακριά από τον ατμό όταν την ανοίγετε.

Τρόπος χρήσης - Πάνω + κάτω καλάθι

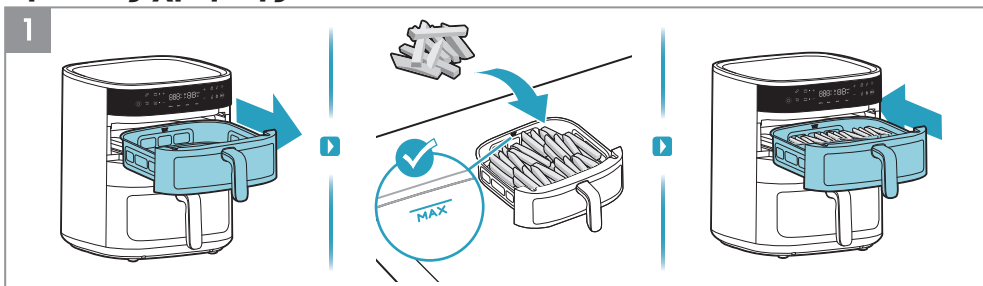

1. Πρώτα, τραβήξτε έξω το πάνω καλάθι και τοποθετήστε τα τρόφιμα στο καλάθι, για παράδειγμα τηγανιτές πατάτες.

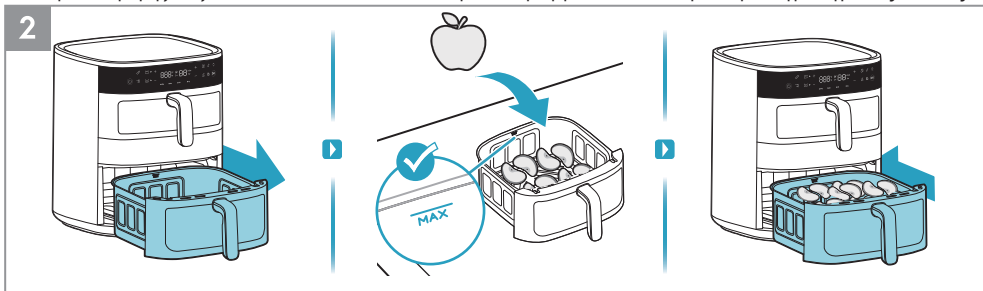

2. Έπειτα, τραβήξτε έξω το κάτω καλάθι και τοποθετήστε τα τρόφιμα στο καλάθι, για παράδειγμα φέτες μήλου.



3. Πατήστε το κουμπί Ενεργοποίηση/Απενεργοποίηση. Πρώτα επιλέξτε το πάνω καλάθι. Έπειτα επιλέξτε την επιθυμητή μέθοδο μαγειρέματος, για παράδειγμα τη λειτουργία ψησίματος στον αέρα. Ρυθμίστε τον χρόνο και τη θερμοκρασία σύμφωνα με τις προτιμήσεις σας ή επιλέξτε μία από τις προκαθορισμένες συνταγές, για παράδειγμα Λαχανικά. Τέλος, πατήστε το κουμπί Αναπαραγωγή/Παύση.



4. Στη συνέχεια, επιλέξτε το κάτω καλάθι. Έπειτα επιλέξτε την επιθυμητή μέθοδο μαγειρέματος, για παράδειγμα λειτουργία αποξήρανσης. Ρυθμίστε τον χρόνο και τη θερμοκρασία σύμφωνα με τις προτιμήσεις σας. Τέλος, πατήστε το κουμπί Αναπαραγωγή/Παύση.

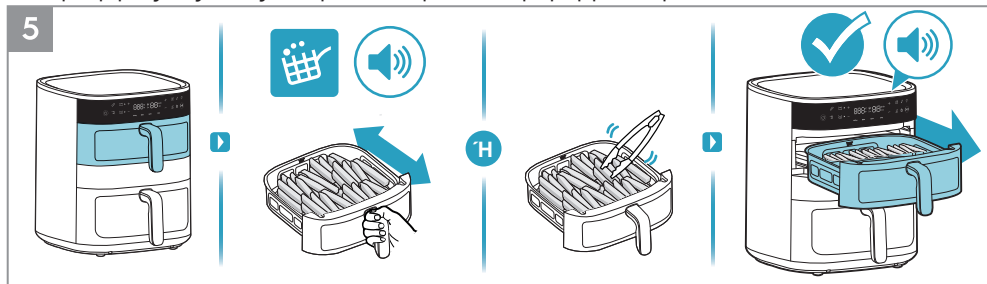

5. Όταν το εικονίδιο “Υπενθύμιση ανακίνησης” ανάβει και ακούγεται ένας ήχος κατά τη διαδικασία του μαγειρέματος, χρησιμοποιήστε εργαλεία ανθεκτικά στη θερμότητα για να γυρίσετε τα τρόφιμα μία φορά ή ανακινήστε προσεκτικά τα τρόφιμα ελαφρώς στο καλάθι ψησίματος. Στο τέλος του χρόνου μαγειρέματος του πάνω καλάθιού, θα ακουστεί ένας χαρακτηριστικός ήχος από τη συσκευή.

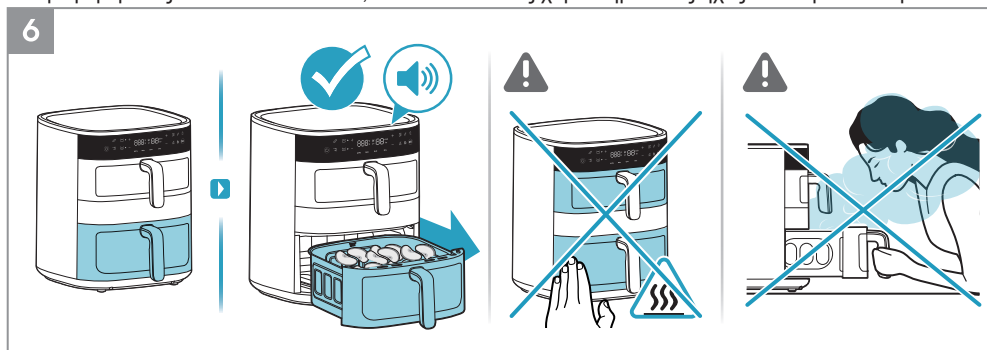

6. Στο τέλος του χρόνου μαγειρέματος του κάτω καλάθιού, θα ακουστεί ένας χαρακτηριστικός ήχος από τη συσκευή.

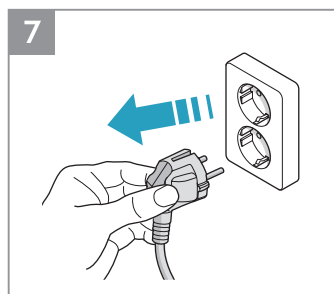

7. Βγάλτε το φις της συσκευής από την πρίζα μετά τη χρήση.

Τρόπος χρήσης - Λειτουργία σύνδεσης

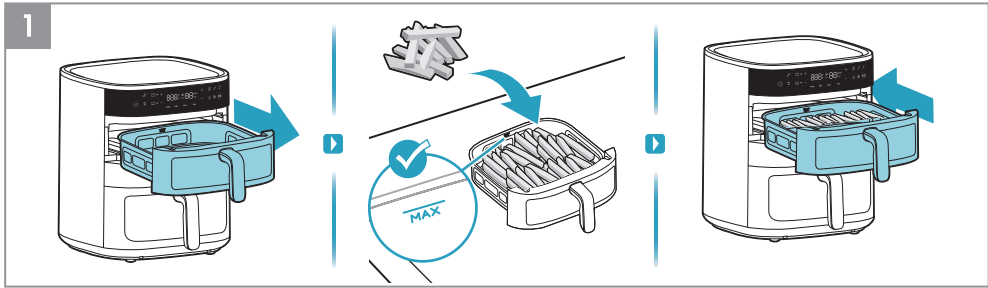

1. Πρώτα, τραβήξτε έξω το πάνω καλάθι και τοποθετήστε τα τρόφιμα στο καλάθι, για παράδειγμα τηγανιτές πατάτες.

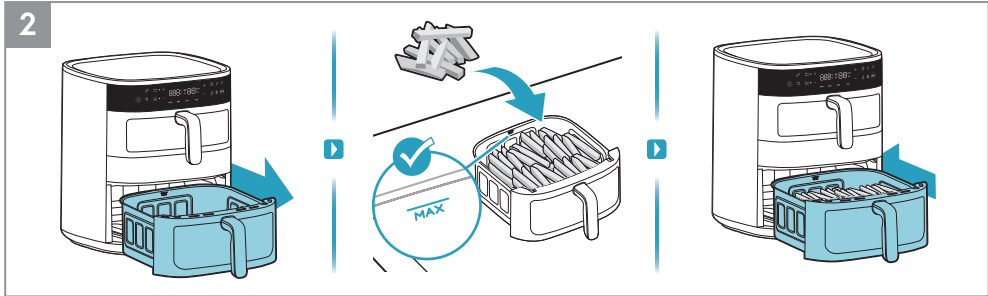

2. Έπειτα, τραβήξτε έξω το κάτω καλάθι και τοποθετήστε τα τρόφιμα στο καλάθι, για παράδειγμα τηγανιτές πατάτες.



3. Πατήστε το κουμπί Ενεργοποίησης/Απενεργοποίησης. Πρώτα επιλέξτε τη λειτουργία σύνδεσης. Έπειτα επιλέξτε την επιθυμητή μέθοδο μαγειρέματος, για παράδειγμα τη λειτουργία ψησίματος στον αέρα. Ρυθμίστε τον χρόνο και τη θερμοκρασία σύμφωνα με τις προτιμήσεις σας ή επιλέξτε μία από τις προκαθορισμένες συνταγές. Τέλος, πατήστε το κουμπί Αναπαραγωγή/Παύση.

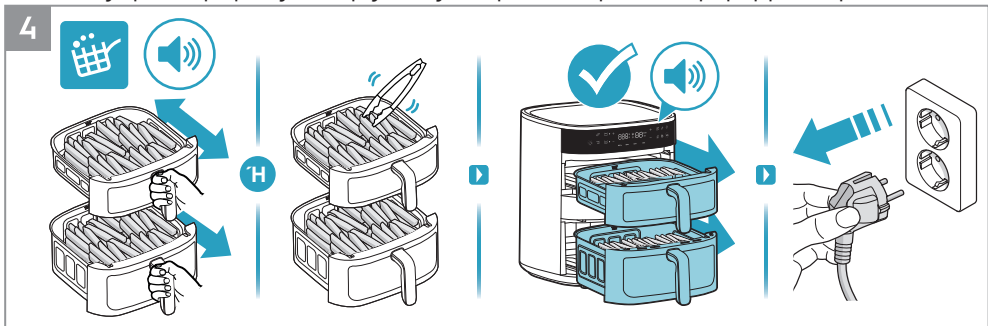

4. Όταν το εικονίδιο "Υπενθύμιση ανακίνησης" ανάβει και ακούγεται ένας ήχος κατά τη διαδικασία του μαγειρέματος, χρησιμοποιήστε εργαλεία ανθεκτικά στη θερμότητα για να γυρίσετε τα τρόφιμα μία φορά ή ανακινήστε προσεκτικά τα τρόφιμα ελαφρώς στο καλάθι ψησίματος. Στο τέλος του χρόνου μαγειρέματος, θα ακουστεί ένας χαρακτηριστικός ήχος από τη συσκευή. Βγάλτε το φις της συσκευής από την πρίζα μετά τη χρήση.

EN
BG
CZ
DE
DK
EE
FI
FR
GR
HR
HU
IT
LT
LV
NO
NL
PL
PT
RO
RU
SE
SI
SK
SR
TR
UA
ES
GE
AL

Τρόπος χρήσης - Λειτουργία συγχρονισμού ολοκλήρωσης

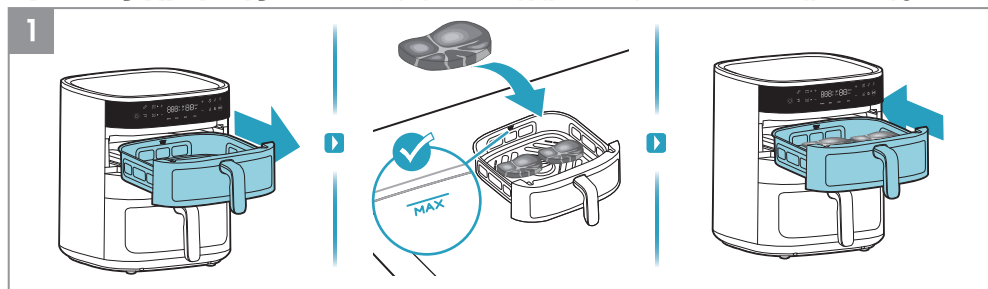

1. Πρώτα, τραβήξτε έξω το πάνω καλάθι και τοποθετήστε τα τρόφιμα στο καλάθι, για παράδειγμα μπριζόλα.

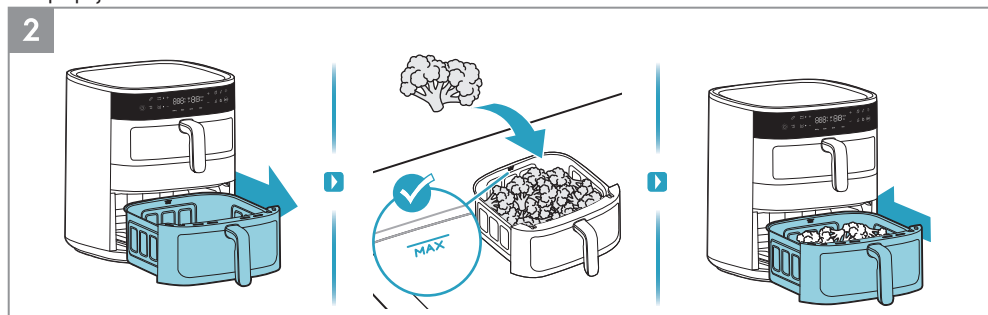

2. Έπειτα, τραβήξτε έξω το κάτω καλάθι και τοποθετήστε τα τρόφιμα στο καλάθι, για παράδειγμα μπρόκολο.



3. Πατήστε το κουμπί Ενεργοποίηση/Απενεργοποίηση. Επιλέξτε τη λειτουργία συγχρονισμού ολοκλήρωσης. Πρώτα επιλέξτε το πάνω καλάθι, έπειτα επιλέξτε την επιθυμητή μέθοδο μαγειρέματος, για παράδειγμα τη λειτουργία ψησίματος στον αέρα. Ρυθμίστε τον χρόνο και τη θερμοκρασία σύμφωνα με τις προτιμήσεις σας ή επιλέξτε μία από τις προκαθορισμένες συνταγές, για παράδειγμα Μπριζόλα.

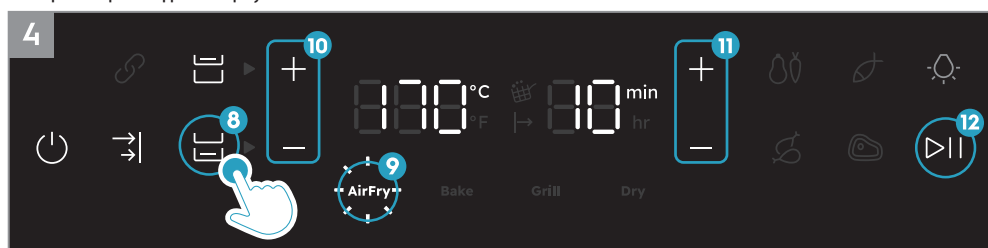

4. Και έπειτα επιλέξτε το κάτω καλάθι, επιλέξτε την επιθυμητή μέθοδο μαγειρέματος, για παράδειγμα τη λειτουργία ψησίματος στον αέρα. Ρυθμίστε τον χρόνο και τη θερμοκρασία σύμφωνα με τις προτιμήσεις σας ή επιλέξτε μία από τις προκαθορισμένες συνταγές. Τέλος, πατήστε το κουμπί Αναπαραγωγή/Παύση.

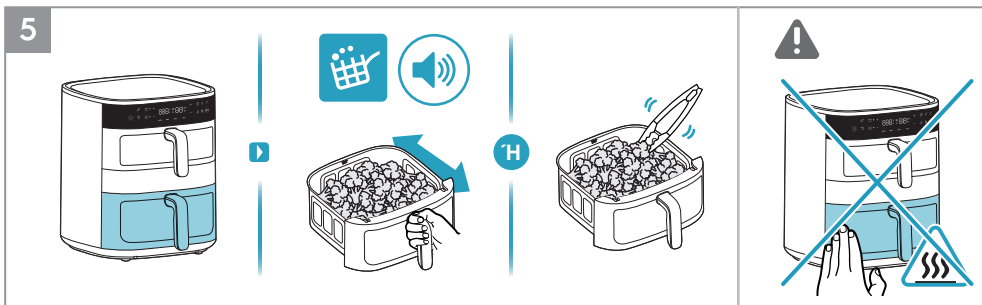

5. Πρώτα, το κάτω καλάθι με τον μεγαλύτερο ρυθμισμένο χρόνο θα έχει προτεραιότητα στο μαγείρεμα. Όταν το εικονίδιο “Υπενθύμιση ανακίνησης” ανάβει και ακούγεται ένας ήχος κατά τη διαδικασία του μαγειρέματος, χρησιμοποιήστε εργαλεία ανθεκτικά στη θερμότητα για να γυρίσετε τα τρόφιμα μία φορά ή ανακινήστε προσεκτικά τα τρόφιμα ελαφρώς στο καλάθι ψησίματος.

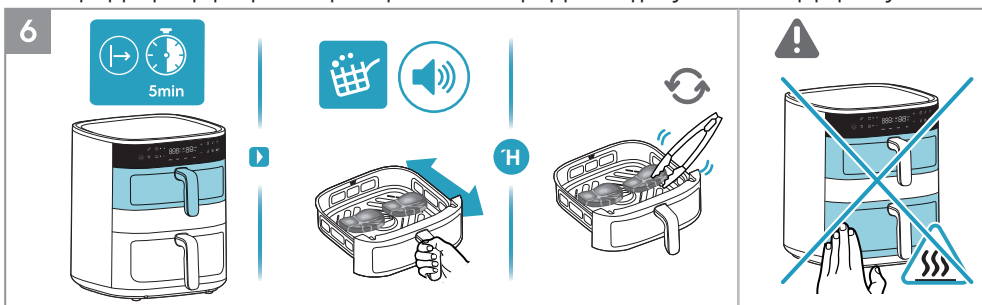

6. Έπειτα, θα αρχίσει το μαγείρεμα στο πάνω καλάθι με τον μικρότερο ρυθμισμένο χρόνο. Όταν το εικονίδιο “Υπενθύμιση ανακίνησης” ανάβει και ακούγεται ένας ήχος κατά τη διαδικασία του μαγειρέματος, χρησιμοποιήστε εργαλεία ανθεκτικά στη θερμότητα για να γυρίσετε τα τρόφιμα μία φορά ή ανακινήστε προσεκτικά τα τρόφιμα ελαφρώς στο καλάθι ψησίματος.

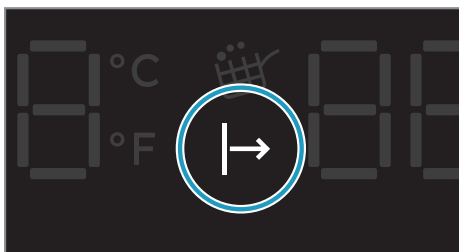

Αναμονή για ένδειξη μαγειρέματος

Όταν η “Λειτουργία συγχρονισμού ολοκλήρωσης” είναι ενεργοποιημένη, το μαγείρεμα στο καλάθι με τον μικρότερο χρόνο μαγειρέματος θα είναι σε αναμονή μέχρι το καλάθι με τον μεγαλύτερο χρόνο μαγειρέματος να λειτουργεί για λίγη ώρα, ώστε και τα δύο καλάθια να ολοκληρώσουν το μαγείρεμα ταυτόχρονα. Κατά τη διάρκεια αυτής της περιόδου, η ένδειξη “αναμονή για μαγείρεμα” θα ανάβει μέχρι να ξεκινήσει το μαγείρεμα.

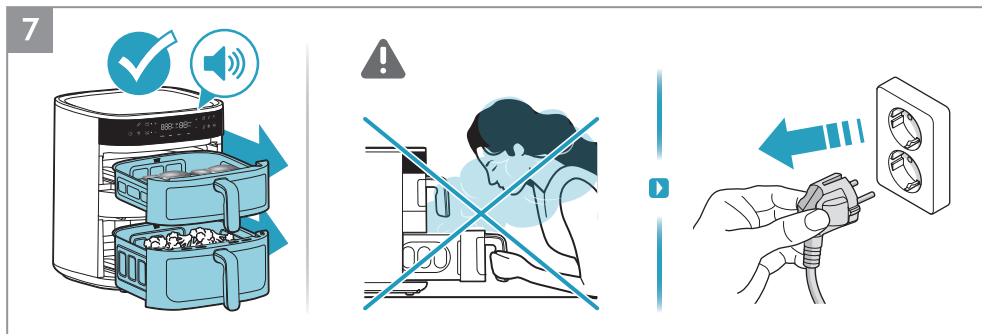

7. Στο τέλος του χρόνου μαγειρέματος, θα ακουστεί ένας χαρακτηριστικός ήχος από τη συσκευή. Βγάλτε το φις της συσκευής από την πρίζα μετά τη χρήση.

Καθαρισμός

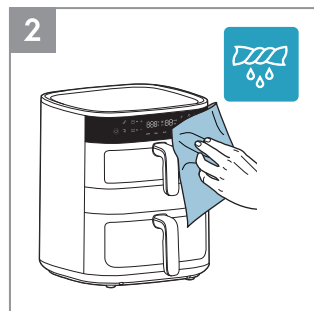
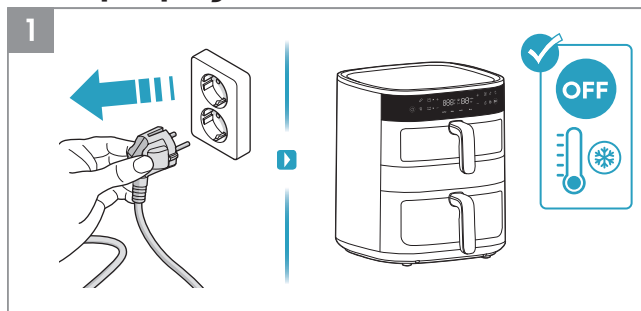

1. Αποσυνδέετε πάντα τη συσκευή από την πρίζα και περιμένετε μέχρι να κρυώσει πριν την καθαρίσετε.
2. Σκουπίστε το εξωτερικό της συσκευής με ένα μαλακό πανί.

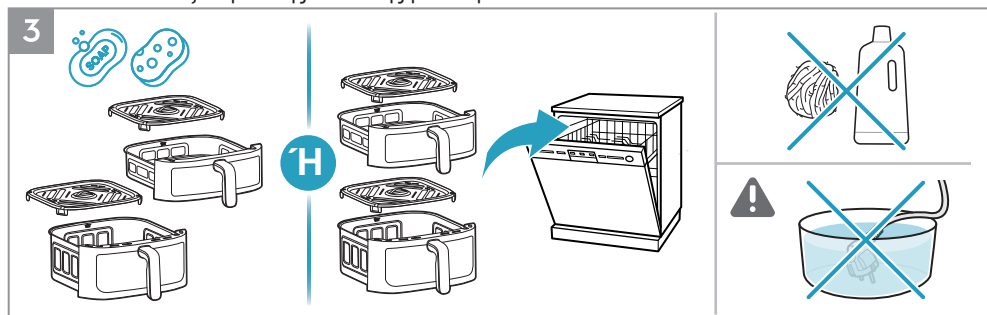

3. Καθαρίστε τον δίσκο και τη σχάρα με ζεστό νερό και σαπούνι για πιάτα ή τοποθετήστε τα στο πλυντήριο πιάτων.

ΔΗΜΕΙΩΣΗ: Αποφύγετε τη χρήση διαβρωτικών προϊόντων καθαρισμού ή μεταλλικών εργαλείων, για την προστασία της αντικολλητικής επίστρωσης.



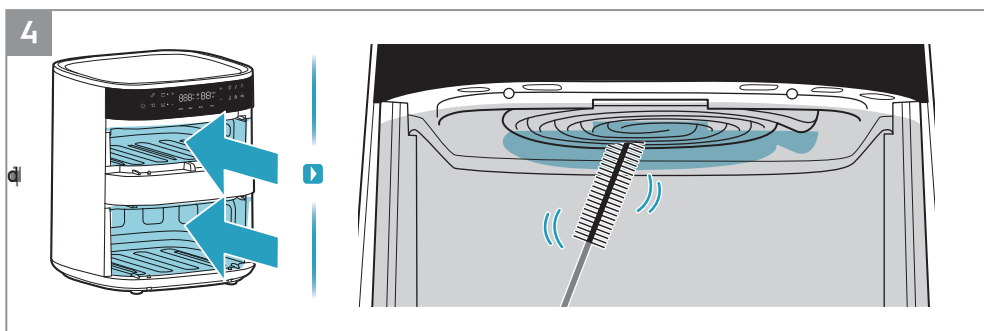









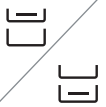





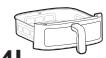

















ΠΡΟΣΟΧΗ: Μη βυθίζετε το προϊόν, το καλώδιο ή το φινι σε νερό ή σε άλλα υγρά.



4. Καθαρίζετε το θερμαντικό στοιχείο με βούρτσα καθαρισμού.



























ΣΗΜΕΙΩΣΗ: Βεβαιωθείτε ότι η συσκευή έχει κρυώσει τελείως πριν καθαρίσετε το θερμαντικό στοιχείο.

Οδηγός μαγειρέματος

							
AirFry	7mm/10mm 	 4L	400g	180°C	18λεπτά		
		 7L	400g	180°C	18λεπτά		
AirFry		 4L	400g	170°C	8λεπτά		
		 7L	400g	170°C	10λεπτά		
AirFry		 4L	400g/2τεμ.	140°C	15λεπτά		
		 7L	400g/2τεμ.	140°C	15λεπτά		
AirFry		 4L	1000g/8τεμ.	180°C	28λεπτά		
		 7L	1000g/8τεμ.	180°C	28λεπτά		
AirFry		 4L	400g/2τεμ.	200°C	10λεπτά		
		 7L	400g/2τεμ.	200°C	10λεπτά		
AirFry		 4L	220g/6ίντσες	160°C	12λεπτά		
		 7L	220g/6ίντσες	160°C	14λεπτά		

EN
BG
CZ
DE
DK
EE
FI
FR
GR
HR
HU
IT
LT
LV
NO
NL
PL
PT
RO
RU
SE
SI
SK
SR
TR
UA
ES
GE
AL

EN
BG
CZ
DE
DK
EE
FI
FR
GR
HR
HU
IT
LT
LV
NO
NL
PL
PT
RO
RU
SE
SI
SK
SR
TR
UA
ES
GE
AL

							
AirFry		 7L	1200g	180°C	55λεπτά		
AirFry		 7L	400g/9τεμ.	160°C	20λεπτά		
Grill		 4L	180g/4τεμ.	180°C	8λεπτά		
Grill		 7L	180g/4τεμ.	180°C	9λεπτά		
Dry		 4L	180g	80°C	3ώρες		
Dry		 7L	180g	80°C	3ώρες		
Dry		 4L	200g	80°C	3ώρες		
Dry		 7L	200g	80°C	3ώρες		

Τι να κάνετε αν...

Πρόβλημα	Ελέγξτε αν...
Δεν μπορείτε να ενεργοποιήσετε ή να λειτουργήσετε τη συσκευή.	<ul style="list-style-type: none"> • Η συσκευή έχει συνδεθεί σωστά στην παροχή ρεύματος. • Τα καλάθια είναι στη σωστή θέση. Βεβαιωθείτε ότι τα έχετε σπρώξει τελείως μέσα στη συσκευή για να ενεργοποιηθεί η τροφοδοσία. • Ο χρόνος μαγειρέματος έχει ρυθμιστεί.
Δεν μπορείτε να εισαγάγετε το καλάθι μέσα στη συσκευή.	<ul style="list-style-type: none"> • Το καλάθι έχει γεμίσει πάνω από τη μέγιστη χωρητικότητα. • Το καλάθι έχει τοποθετηθεί σωστά. Πρέπει να κουμπώσει με τον χαρακτηριστικό ήχο όταν το τοποθετείτε μέσα στη μονάδα. • Υπάρχει ένα αντικείμενο κάτω από το καλάθι που σας εμποδίζει να κλείσετε τη συσκευή σωστά.
Βγαίνει λευκός καπνός από τη συσκευή.	<ul style="list-style-type: none"> • Το φαγητό που ετοιμάζετε είναι πολύ λιπαρό. • Το καλάθι, η σχάρα και το θερμαντικό στοιχείο είναι καθαρά.
Στην οθόνη εμφανίζεται η ένδειξη E1	•Ανοιχτό κύκλωμα πάνω καλαθιού.
Στην οθόνη εμφανίζεται η ένδειξη E2	•Βραχυκύκλωμα πάνω καλαθιού.
Στην οθόνη εμφανίζεται η ένδειξη E3	•Ανοιχτό κύκλωμα κάτω καλαθιού.
Στην οθόνη εμφανίζεται η ένδειξη E4	•Βραχυκύκλωμα κάτω καλαθιού.
Στην οθόνη εμφανίζεται η ένδειξη E5	•Σφάλμα επικοινωνίας ελέγχου PCBA.
Στην οθόνη εμφανίζεται η ένδειξη E6	•Σφάλμα επικοινωνίας ισχύος PCBA.

* Σε περίπτωση που στην οθόνη εμφανίζονται κωδικοί σφάλματος, η συσκευή πρέπει να επισκευαστεί από ένα κέντρο σέρβις.

Τεχνικά στοιχεία

Προϊόν	Φριτέζα αέρος
Μοντέλο	EAFD11B
Τάση (V~)	220 V ~ 240 V
Ισχύς (W)	2700 W
Συχνότητα (Hz)	50 ~ 60 Hz
Χωρητικότητα	4 λίτρα + 7 λίτρα



Priručnik s uputama

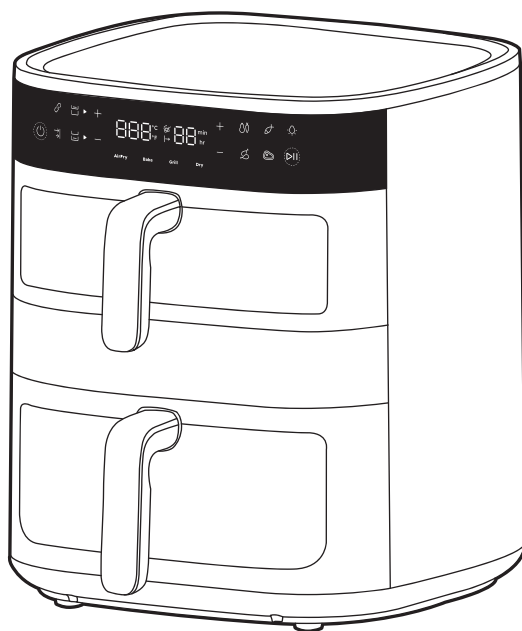

800 dvostruka friteza na vrući zrak

Opći pregled

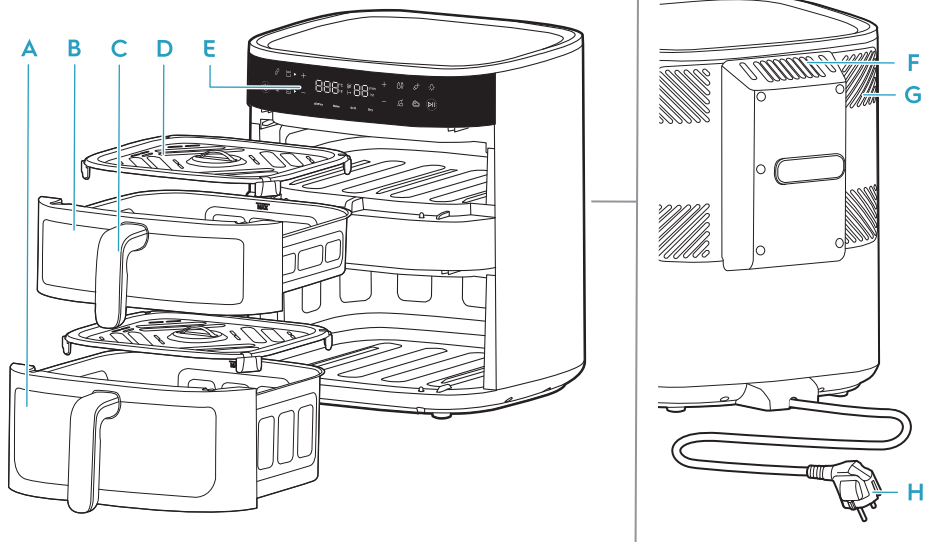

- | | | | |
|-----------------------------|-----------------------|--------------------------|--------------------------|
| A Donja košara (7L) | C Drška košare | E Kontrolna ploča | G Sustav hlađenja |
| B Gornja košara (4L) | D Rešetka | F Izlaz zraka | H Glavni kabel |

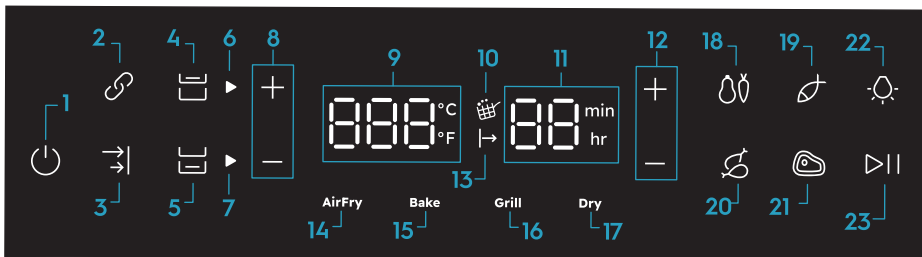

- | | | | |
|--|---|--|------------------------------|
| 1. Uključivanje/
isključivanje | 6. Indikator gornje
košare | 11. Indikator vremena
(AirFry: 1 do 99 min,
dehidracija: 1 do 5 h) | 17. Funkcija sušenja |
| 2. Funkcija
povezivanja | 7. Indikator donje
košare | 12. Upravljanje
vremenom | 18. Povrće |
| 3. Funkcija
sinkronizacije
završetka | 8. Reguliranje
temperature | 13. Čekanje pripreme
hrane | 19. Riba |
| 4. Upravljanje
gornjom košarom | 9. Indikator
temperature
(40 do 200 °C) | 14. Funkcija AirFry | 20. Piletina |
| 5. Upravljanje
donjom košarom | 10. Podsjetnik za
protresanje | 15. Funkcija pečenja | 21. Odrezak |
| | | 16. Funkcija roštilja | 22. Reguliranje svjetla |
| | | | 23. Reprodukcijska/
pauza |

Prije prve upotrebe

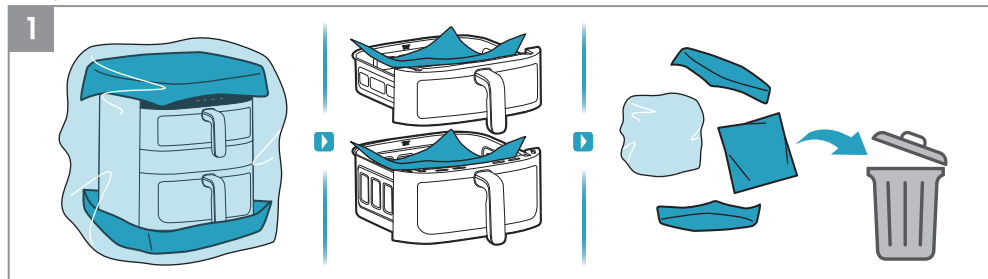

1. Uklonite svu ambalažu i zaštitni materijal.

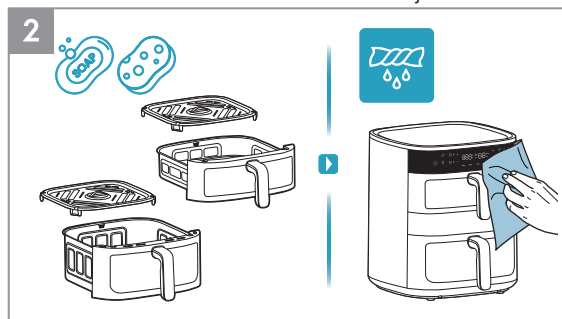

2. Očistite posudu i rešetku toplom vodom i sapunom za posuđe. Obrišite uređaj iznutra i izvana mekom krpom.

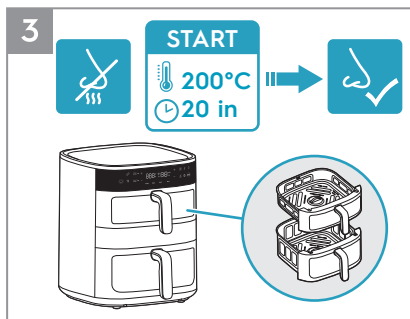



3. Normalno je da novi uređaj ispušta neugodne mirise pri prvih nekoliko upotreba. Kako biste to izbjegli, prije prve upotrebe pustite praznu fritezu na vrući zrak da radi 20 minuta na 200 °C.

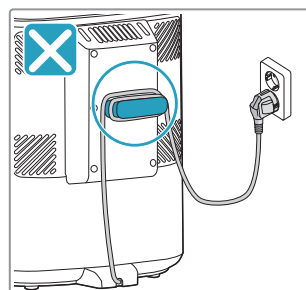
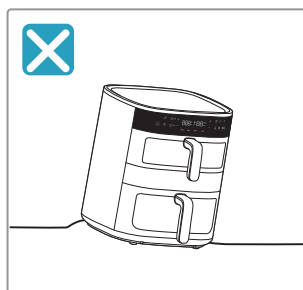
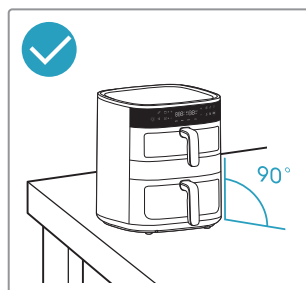
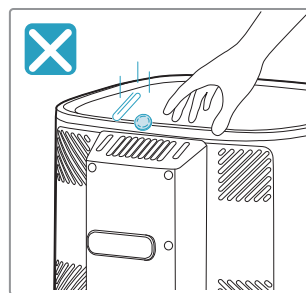
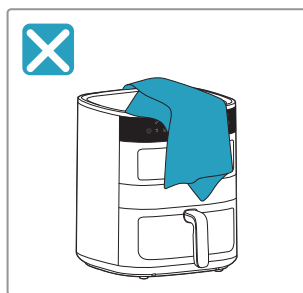
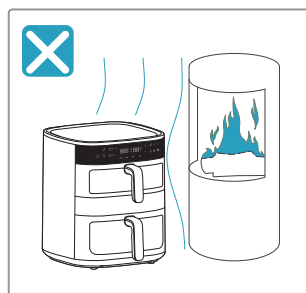



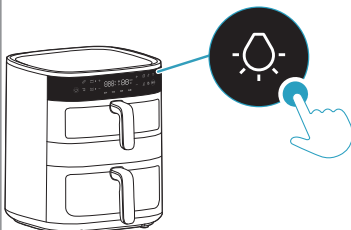
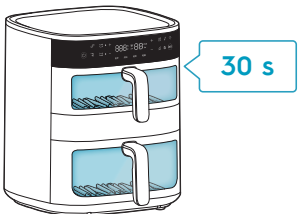

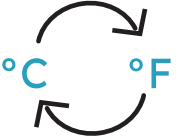



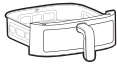

! Mjere sigurnosti



Reguliranje svjetla i pretvorba ljestvice temperature





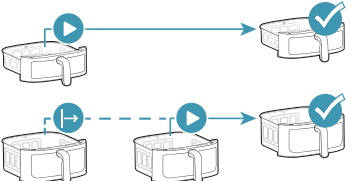





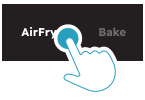



 <p>Reguliranje svjetla</p>		
<p>°C/°F</p> <p>Pretvorba skale za temperaturu</p>		

Odabir košare

	 <p>4L</p>	 <p>7L</p>	
 <p>Gornja košara</p>			
 <p>Donja košara</p>			
 <p>Funkcija povezivanja</p>			
 <p>Funkcija sinkronizacije završetka</p>			

- EN
- BG
- CZ
- DE
- DK
- EE
- FI
- FR
- GR
- HR
- HU
- IT
- LT
- LV
- NO
- NL
- PL
- PT
- RO
- RU
- SE
- SI
- SK
- SR
- TR
- UA
- ES
- GE
- AL

Unaprijed postavljene funkcije

					
AirFry	180°C	15in	60-200°C	1-99in	
	170°C	10in	60-200°C	1-99in	
	140°C	15in	60-200°C	1-99in	
	180°C	30in	60-200°C	1-99in	
	200°C	10in	60-200°C	1-99in	
Bake	170°C	15in	60-200°C	1-99in	
Grill	200°C	5in	60-200°C	1-99in	
Dry	80°C	5h	40-80°C	1-5h	

Prije pripreme hrane

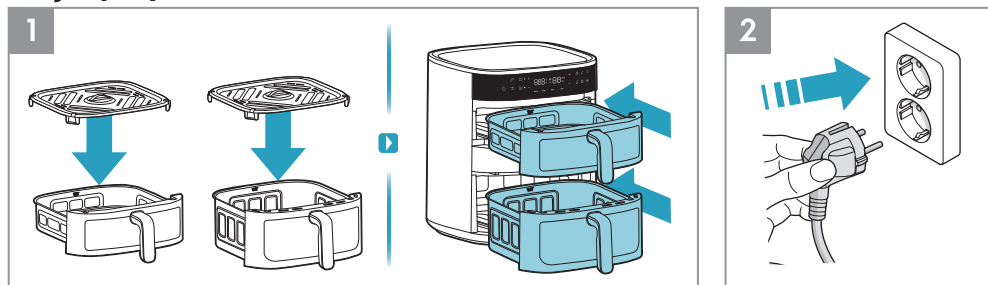

1. Prije svake pripreme hrane stavite rešetku u košaru (silikonsku podlogu rešetke otpornu na toplinu nije potrebno uklanjati) i potpuno gurnite košaru u uređaj.
2. Gurnite utikač u električnu utičnicu.

Kako koristiti – jedna košara

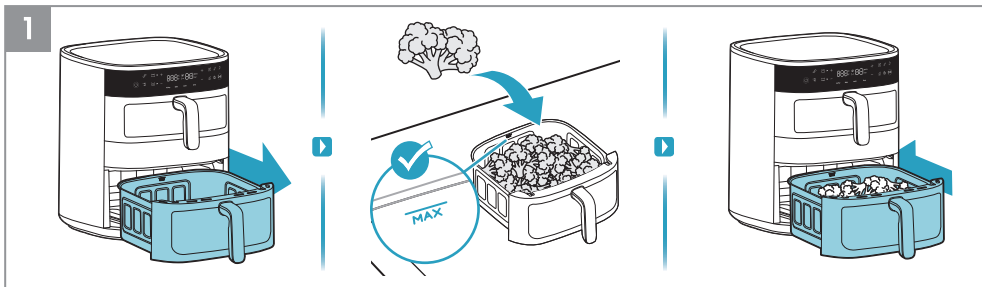

1. Izvucite jednu košaru i stavite je na stabilnu površinu, stavite hranu u košaru, pazeći na oznaku kapaciteta "MAX". Zatim košaru s hranom potpuno vratite u uređaj.

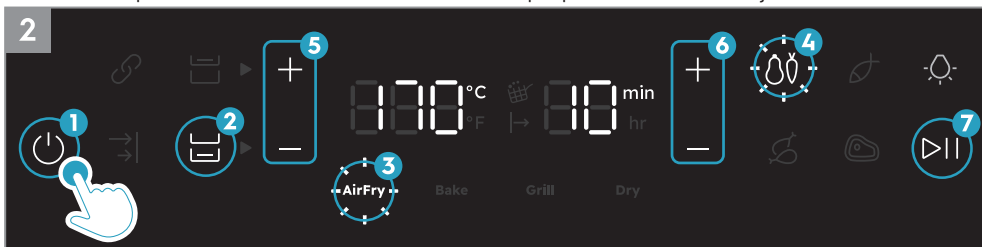

2. Pritisnite gumb za uključivanje/isključivanje. Prvo odaberite košaru s hranom. Zatim odaberite željeni način pripreme hrane, primjerice, funkciju Air Fry. Prilagodite vrijeme i temperaturu na željenu razinu ili odaberite jedan od unaprijed postavljenih recepata, primjerice, Povrće. Naposljetku pritisnite gumb za reprodukciju/pauzu.

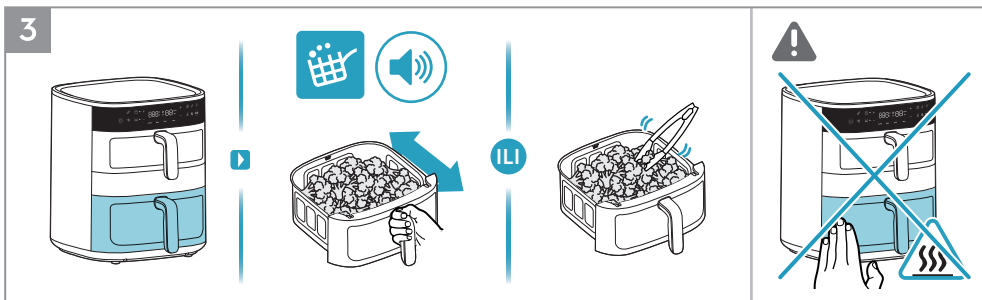

3. Ako se tijekom pripreme hrane uključi ikona "podsjetnika za protresanje" i oglasi se zvučni signal, alatima otpornima na toplinu jednom okrenite hranu ili lagano i pažljivo protresite hranu u košari za prženje.

- ⚠ **OPREZ:** Ne tresite košaru za prženje snažno kako biste izbjegli prskanje hrane i kako se ne biste opekli.
⚠ **OPREZ:** Oprezno postupajte s vrućim površinama dok upotrebljavate uređaj.

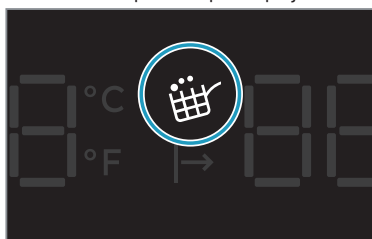

Podsjetnik za protresanje

"Podsjetnik za protresanje" se aktivira tijekom funkcije Air Fry zajedno s unaprijed postavljenim receptima kao što su Povrće, Riba, Pileći bataci i Odrezak.

Kada je vrijeme za protresanje ili okretanje hrane, ikona "Podsjetnik za protresanje" će se uključiti i treptati jednu minutu, dok će se zvučni signal ponoviti tri puta.

"Podsjetnik za protresanje" nije obavezan, stoga će se priprema hrane nastaviti prema uobičajenom postupku čak i ako je ne okrenete ili ne protresete.

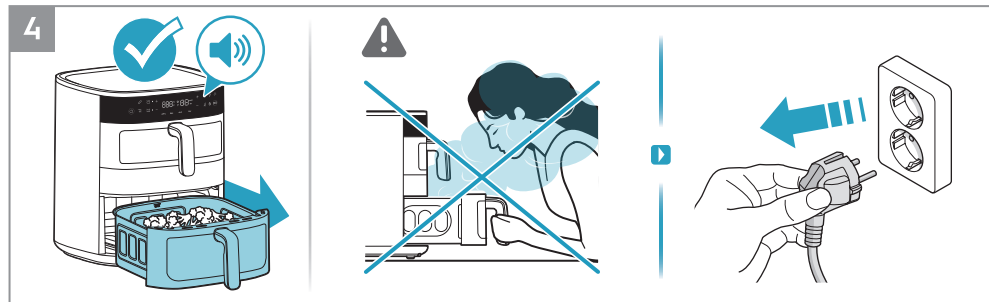

4. Po isteku vremena pripreme hrane, uređaj će se oglasiti zvučnim signalom. Pažljivo izvadite košaru i stavite je na površinu otpornu na toplinu. Iskopčajte uređaj nakon upotrebe.

⚠ **OPREZ:** Ako košaru otvorite usred ili nakon završetka kuhanja, može izaći vruća para. Odmaknite lice, ruke i šake od pare prilikom otvaranja.

Kako koristiti – gornja + donja košara

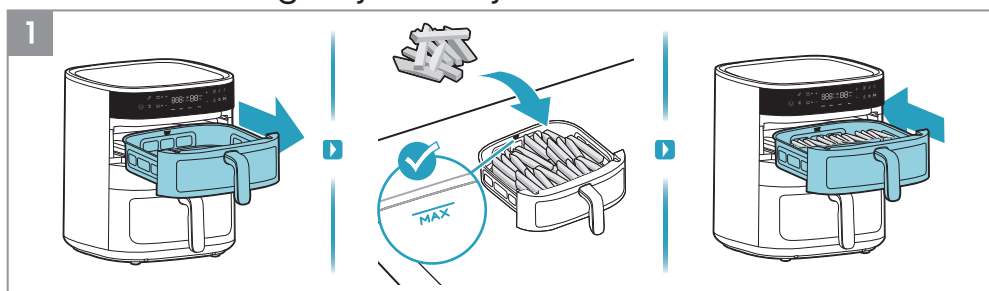

1. Prvo izvucite gornju košaru i stavite hranu u istu, primjerice, krumpiriće.

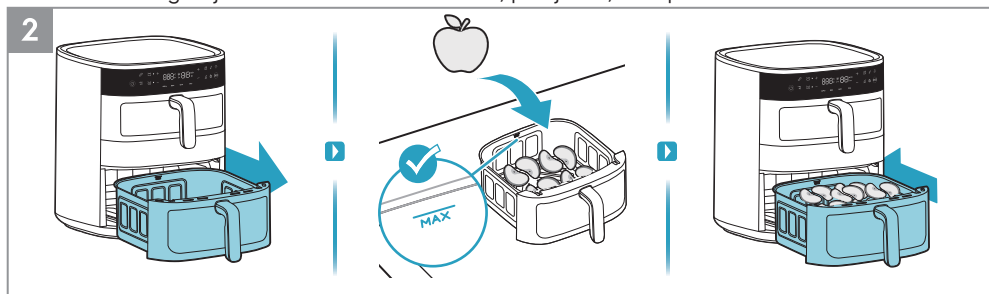

2. Zatim izvucite donju košaru i stavite hranu u istu, primjerice, kriške jabuke.



3. Pritisnite gumb za uključivanje/isključivanje. Prvo odaberite gornju košaru. Zatim odaberite željeni način pripreme hrane, primjerice, funkciju Air Fry. Prilagodite vrijeme i temperaturu na željenu razinu ili odaberite jedan od unaprijed postavljenih recepata, primjerice, Povrće. Naposljetku pritisnite gumb za reprodukciju/pauzu.



4. Zatim odaberite donju košaru. Nakon toga odaberite željeni način pripreme hrane, primjerice, funkciju sušenja. Prilagodite vrijeme i temperaturu na željenu razinu. Naposljetku pritisnite gumb za reprodukciju/pauzu.

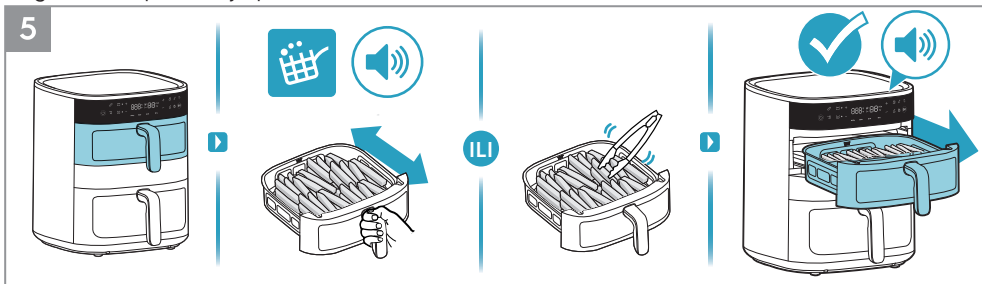

5. Ako se tijekom pripreme hrane uključi ikona "podsjetnika za protresanje" i oglasi se zvučni signal, alatima otpornima na toplinu jednom okrenite hranu ili lagano i pažljivo protresite hranu u košari za prženje. Po isteku vremena pripreme hrane u gornjoj košari, uređaj će se oglasiti zvučnim signalom.

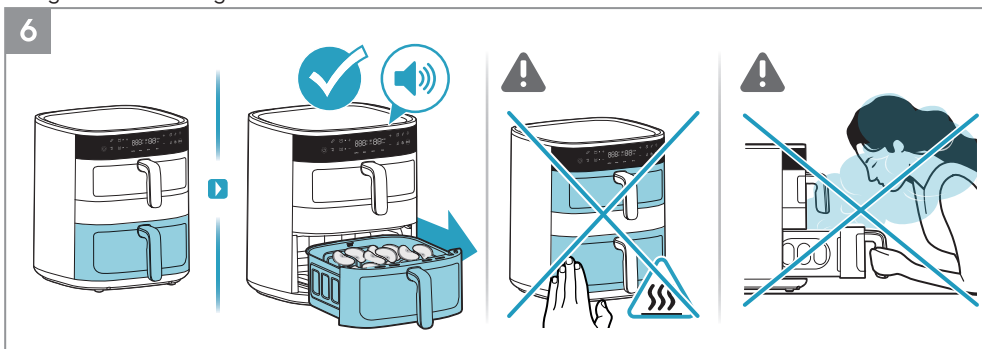

6. Po isteku vremena pripreme hrane u donjoj košari, uređaj će se oglasiti zvučnim signalom.

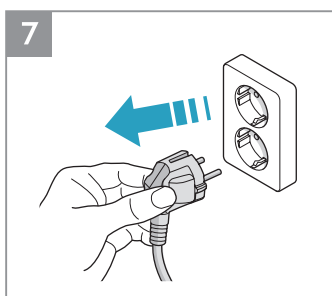

7. Iskopčajte uređaj nakon upotrebe.

EN
BG
CZ
DE
DK
EE
FI
FR
GR
HR
HU
IT
LT
LV
NO
NL
PL
PT
RO
RU
SE
SI
SK
SR
TR
UA
ES
GE
AL

Kako koristiti – funkcija povezivanja

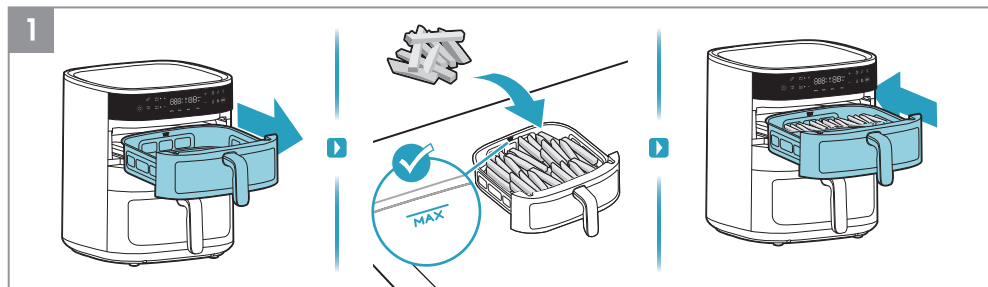

1. Prvo izvucite gornju košaru i stavite hranu u istu, primjerice, krumpiriće.

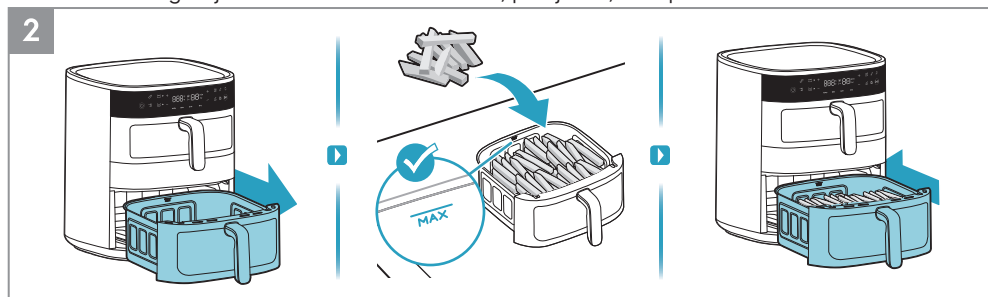

2. Zatim izvucite donju košaru i stavite hranu u istu, primjerice, krumpiriće.

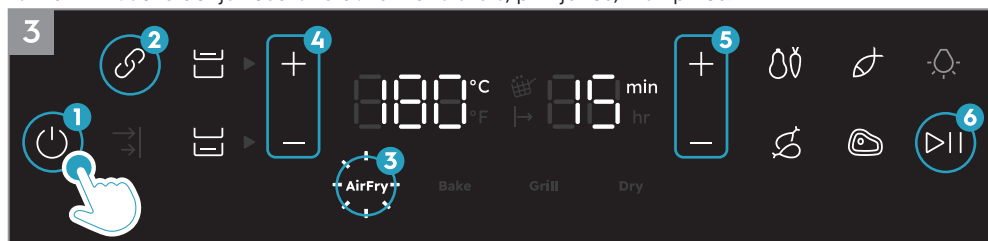

3. Pritisnite gumb za uključivanje/isključivanje. Prvo odaberite funkciju povezivanja. Zatim odaberite željeni način pripreme hrane, primjerice, funkciju Air Fry. Prilagodite vrijeme i temperaturu na željenu razinu ili odaberite jedan od unaprijed postavljenih recepata. Naposljetku pritisnite gumb za reprodukciju/pauzu.

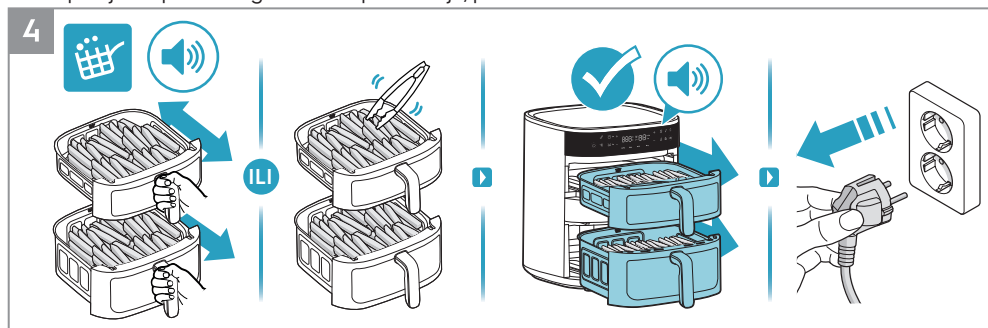

4. Ako se tijekom pripreme hrane uključi ikona "podsjetnika za protresanje" i oglasi se zvučni signal, alatima otpornima na toplinu jednom okrenite hranu ili lagano i pažljivo protresite hranu u košari za prženje. Po isteku vremena pripreme hrane, uređaj će se oglasiti zvučnim signalom. Iskopčajte uređaj nakon upotrebe.

Kako koristiti – funkcija sinkronizacije završetka

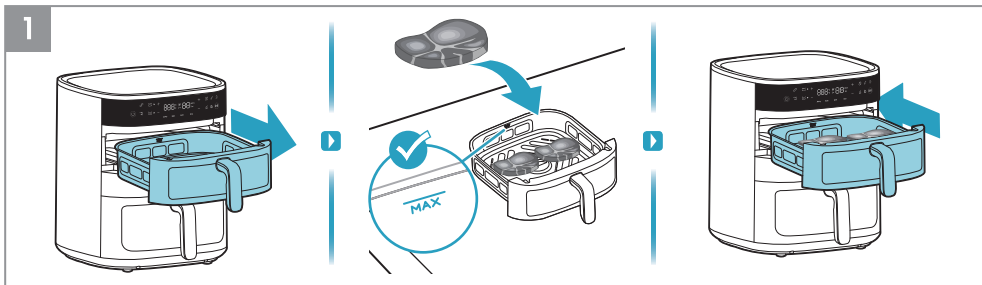

1. Prvo izvucite gornju košaru i stavite hranu u istu, primjerice, odrezak.

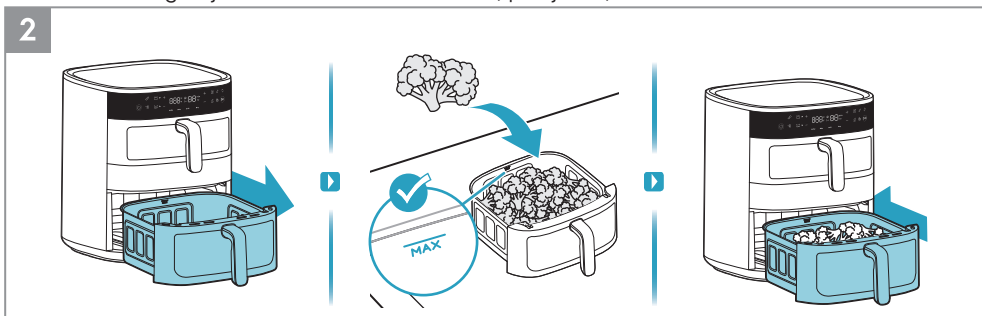

2. Zatim izvucite donju košaru i stavite hranu u istu, primjerice, brokulu.



3. Pritisnite gumb za uključivanje/isključivanje. Odaberite funkciju sinkronizacije završetka. Prvo odaberite gornju košaru, zatim odaberite željeni način pripreme hrane, primjerice, funkciju Air Fry. Prilagodite vrijeme i temperaturu na željenu razinu ili odaberite jedan od unaprijed postavljenih recepata, primjerice, Odrezak.



4. Zatim odaberite donju košaru i odaberite željeni način pripreme hrane, primjerice, funkciju Air Fry. Prilagodite vrijeme i temperaturu na željenu razinu ili odaberite jedan od unaprijed postavljenih recepata. Naposljetku pritisnite gumb za reprodukciju/pauzu.

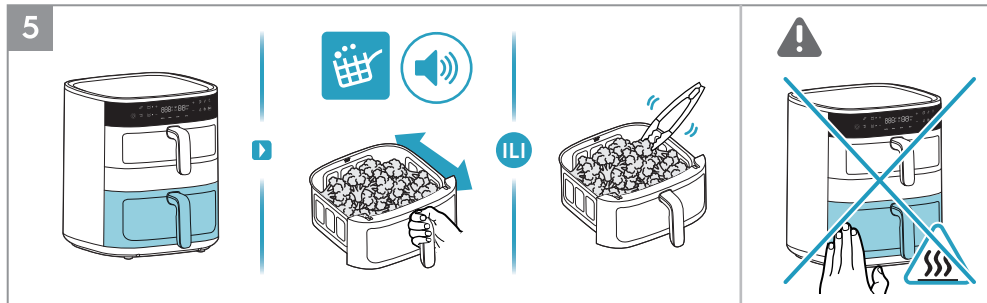

5. Prvo, donja košara s većim postavljenim vremenom imat će prioritet u pripremi hrane. Ako se tijekom pripreme hrane uključi ikona “podsjetnika za protresanje” i ogłosi se zvučni signal, alatima otpornima na toplinu jednom okrenite hranu ili lagano i pažljivo protresite hranu u košari za prženje.

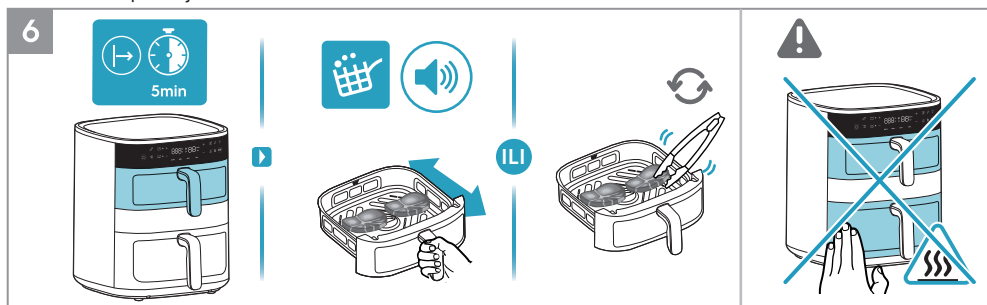

6. Drugo, gornja košara s kraćim postavljenim vremenom započet će s pripremom hrane. Ako se tijekom pripreme hrane uključi ikona “podsjetnika za protresanje” i ogłosi se zvučni signal, alatima otpornima na toplinu jednom okrenite hranu ili lagano i pažljivo protresite hranu u košari za prženje.

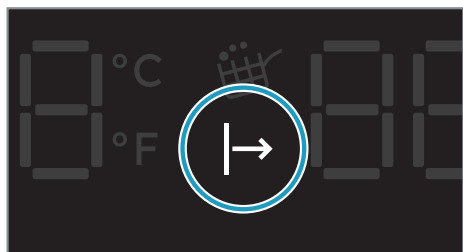

Indikator čekanja pripreme hrane

Ako je aktivirana “Funkcija sinkronizacije završetka”, košara s kraćim vremenom pripreme hrane pričekat će da košara s većim vremenom pripreme hrane počne pripremati hranu neko vrijeme, tako da obje košare mogu završiti pripremu istovremeno. Tijekom tog razdoblja, “indikator čekanja pripreme hrane” će svijetliti dok priprema hrane ne započne.

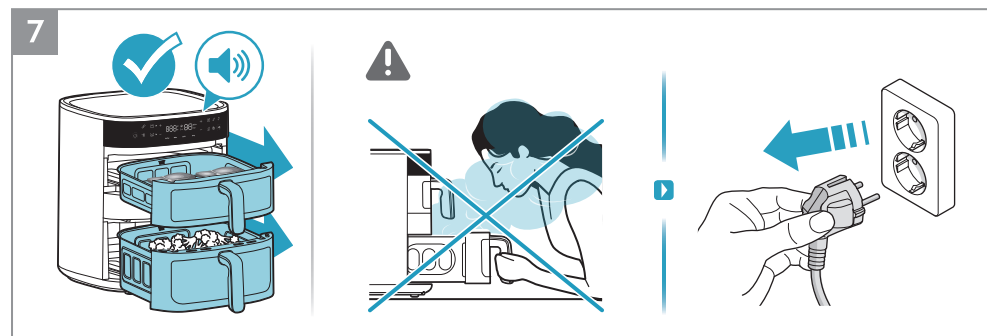

7. Po isteku vremena pripreme hrane, uređaj će se oglašiti zvučnim signalom. Iskopčajte uređaj nakon upotrebe.

Čišćenje

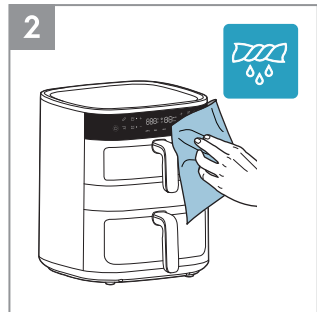
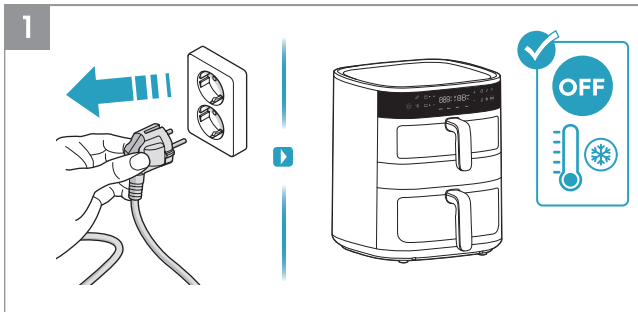

1. Svakako isključite uređaj iz struje i pričekajte da se ohladi prije čišćenja.
2. Obrišite uređaj izvana mekom krpom.

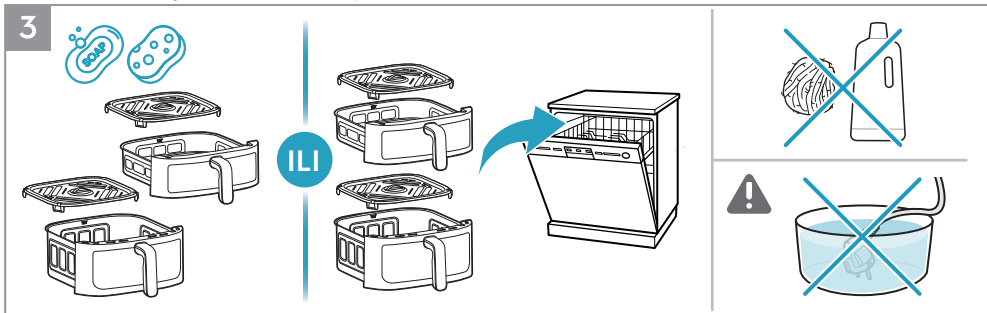

3. Očistite posudu i rešetku toplom vodom i sapunom za posuđe ili ih stavite u perilicu posuđa.

▲NAPOMENA: Nemojte koristiti abrazivna sredstva za čišćenje ili metalne alate kako biste zaštilili neprianjajući površinski sloj.

OPREZ: Nikako ne uranjajte proizvod, njegov kabel ili utikač u vodu ili bilo koju drugu tekućinu.

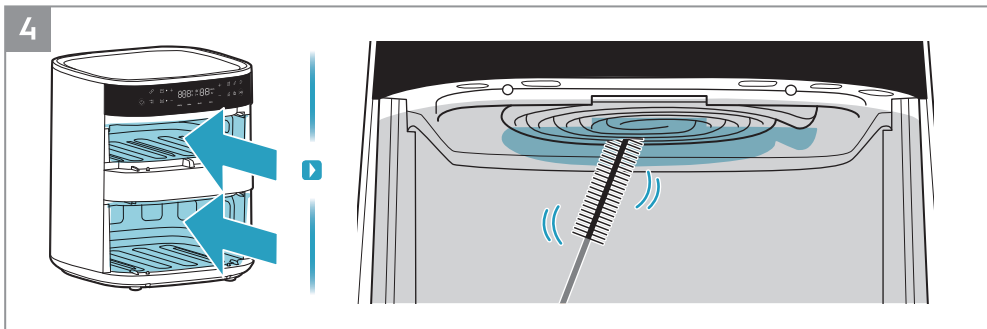











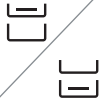

















































4. Očistite grijaći element četkom za čišćenje.

NAPOMENA: Prije čišćenja grijaćeg elementa uvjerite se da se uređaj potpuno ohladio.

EN
BG
CZ
DE
DK
EE
FI
FR
GR
HR
HU
IT
LT
LV
NO
NL
PL
PT
RO
RU
SE
SI
SK
SR
TR
UA
ES
GE
AL

Vodič za pripremu hrane

							
AirFry	7mm/10mm 	4L 	400g	180°C	18min		
		7L 	400g	180°C	18min		
AirFry		4L 	400g	170°C	8min		
		7L 	400g	170°C	10min		
AirFry		4L 	400g/2komada	140°C	15min		
		7L 	400g/2komada	140°C	15min		
AirFry		4L 	1000g/8komada	180°C	28min		
		7L 	1000g/8komada	180°C	28min		
AirFry		4L 	400g/2komada	200°C	10min		
		7L 	400g/2komada	200°C	10min		
AirFry		4L 	220g/6inča	160°C	12min		
		7L 	220g/6inča	160°C	14min		

Recipe							
AirFry		 7L	1200g	180°C	55min		
AirFry		 7L	400g/9komada	160°C	20min		
Grill		 4L	180g/4komada	180°C	8min		
		 7L	180g/4komada	180°C	9min		
Dry		 4L	180g	80°C	3h		
		 7L	180g	80°C	3h		
Dry		 4L	200g	80°C	3h		
		 7L	200g	80°C	3h		

- EN
- BG
- CZ
- DE
- DK
- EE
- FI
- FR
- GR
- HR**
- HU
- IT
- LT
- LV
- NO
- NL
- PL
- PT
- RO
- RU
- SE
- SI
- SK
- SR
- TR
- UA
- ES
- GE
- AL

Što ako...

Problem	Provjerite...
Ne možete aktivirati ili upravljati uređajem.	<ul style="list-style-type: none"> • Uređaj je ispravno spojen na električnu mrežu. • Košare su u ispravnom položaju. Uvjerite se da su do kraja gurnute u uređaj kako biste omogućili napajanje električnom energijom. • Vrijeme pripreme hrane je postavljeno.
Ne možete gurnuti košaru u uređaj.	<ul style="list-style-type: none"> • Košara je napunjena preko kapaciteta. • Košara je ispravno postavljena. Treba sjesti na mjesto kada je postavite u uređaj. • Ispod košare se nalazi predmet koji sprječava njezino pravilno zatvaranje.
Iz uređaja izlazi bijeli dim.	<ul style="list-style-type: none"> • Hrana koju pripremate je premasna. • Košara, rešetka i grijači element su čisti.
Na zaslonu se prikazuje E1	• Otvoreni krug gornje košare.
Na zaslonu se prikazuje E2	• Otvoreni krug gornje košare.
Na zaslonu se prikazuje E3	• Otvoreni krug donje košare.
Na zaslonu se prikazuje E4	• Kratki spoj donje košare.
Na zaslonu se prikazuje E5	• Pogreška komunikacije upravljačke tiskane pločice.
Na zaslonu se prikazuje E6	• Pogreška komunikacije tiskane pločice napajanja.

* Ako se na zaslonu prikažu kodovi pogrešaka, uređaj je potrebno popraviti u servisnom centru.

Tehnički podaci

Proizvod	Friteza na vrući zrak
Model	EAFD11B
Napon (V ~)	220 V - 240 V
Snaga (W)	2700 W
Frekvencija (Hz)	50 ~ 60 Hz
Kapacitet	4 L + 7 L



Kezelési útmutató

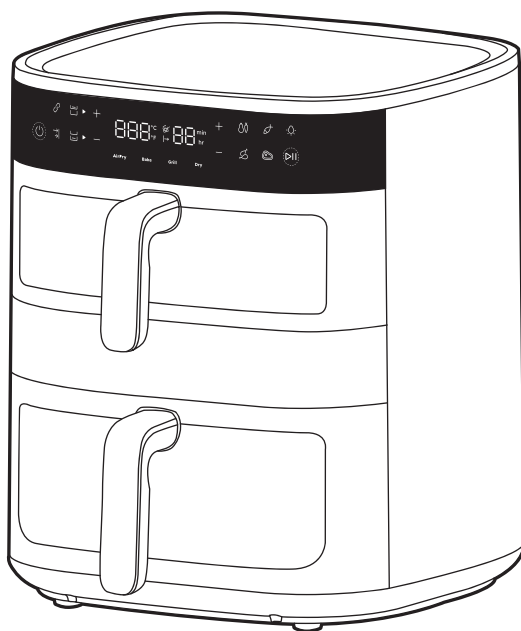

800 dupla forrólevegős sütő

Általános áttekintés

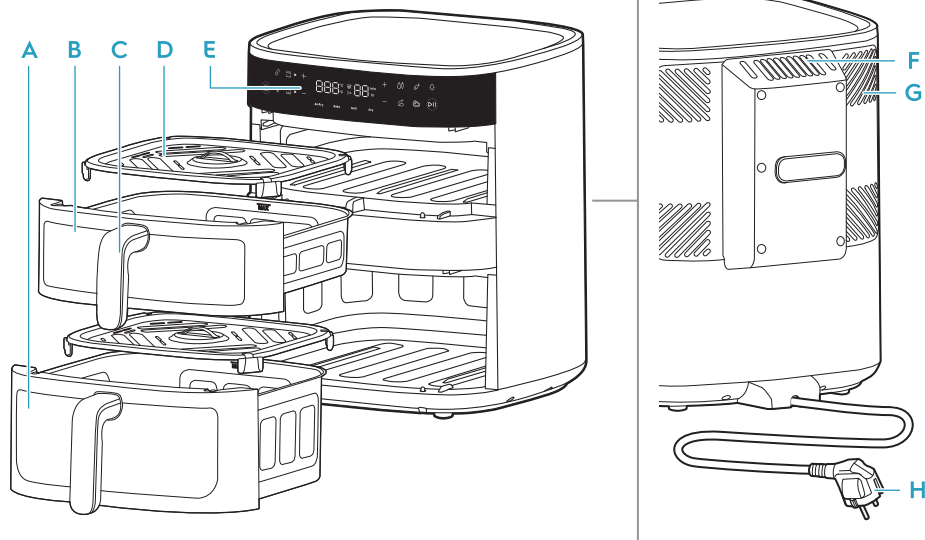

- | | | | |
|---------------------------|--------------------|------------------------|-------------------------|
| A Alsó kosár (7L) | C Kosárfogó | E Kezelőpanel | G Hűtőrendszer |
| B Felső kosár (4L) | D Rács | F Levegőkimenet | H Hálózati kábel |

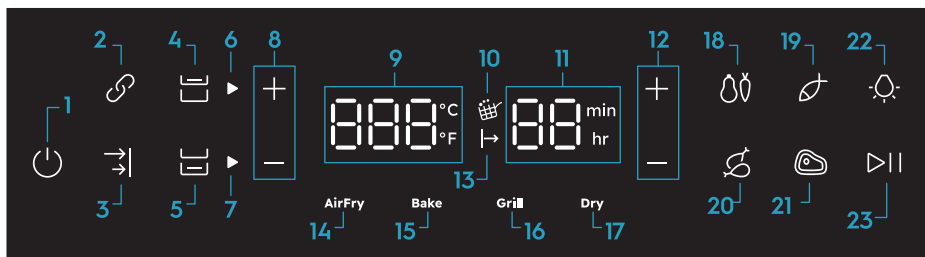

- | | | | |
|------------------------------------|---|--------------------------------|--------------------------|
| 1. Be/ki | 8. Hőmérséklet szabályozás | 14. Forrólevegős sütés funkció | 21. Steak |
| 2. Kapcsolat funkció | 9. Hőmérséklet kijelző (40-200°C) | 15. Sütés funkció | 22. Világítás érintőgomb |
| 3. Szinkronizált befejezés funkció | 10. Rázási emlékeztető | 16. Grillezés funkció | 23. Működés/szünet |
| 4. Felső kosár érintőgomb | 11. Idő kijelző (Forrólevegős sütés: 1-99 perc, Aszalás: 1-5 óra) | 17. Aszalás funkció | |
| 5. Alsó kosár érintőgomb | 12. Idő érintőgomb | 18. Zöldségek | |
| 6. Felső kosár kijelző | 13. Sütésre várakozás | 19. Hal | |
| 7. Alsó kosár kijelző | | 20. Csirke | |

Az első használat előtt

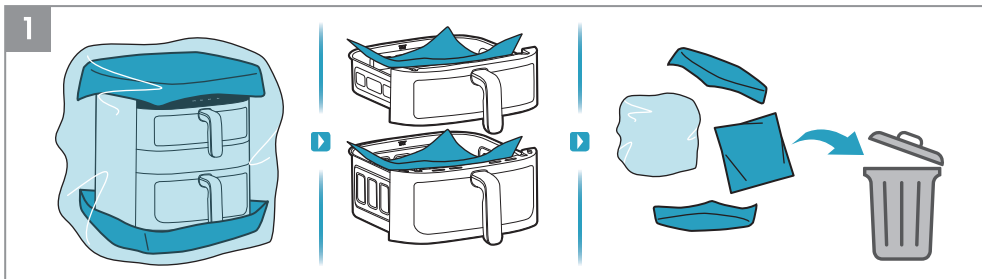

1. Távolítsa el minden csomagoló- és védőanyagot.

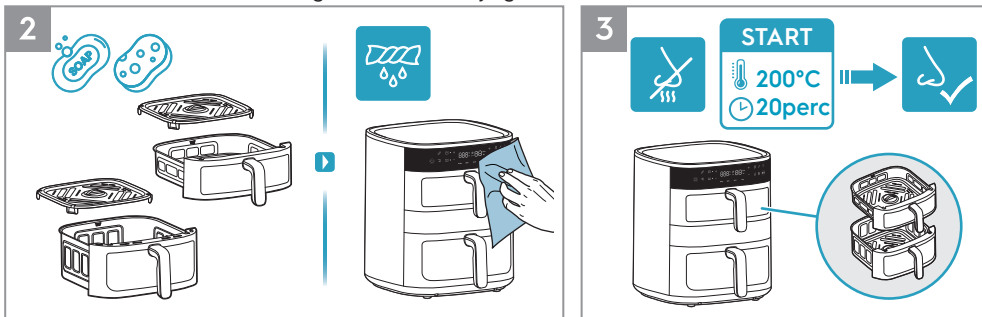

2. Meleg mosogatószeres vízzel tisztítsa meg a serpenyőt és a rácsot. Egy puha kendővel törölje le a készülék belsejét és külsejét.

3. Az egy normális jelenség, hogy egy új készülék szagokat bocsát ki az első néhány alkalommal. Ennek elkerülésére 20 percig 200°C-on működtesse az üres forrólevegős sütőt.

! Biztonsági óvintézkedések

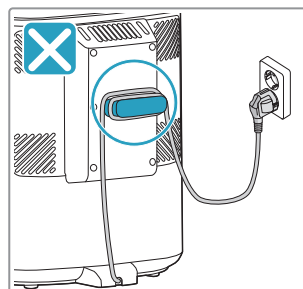
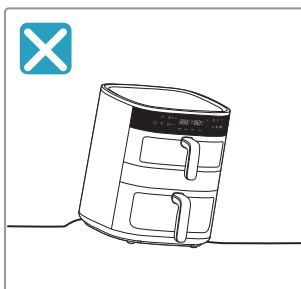
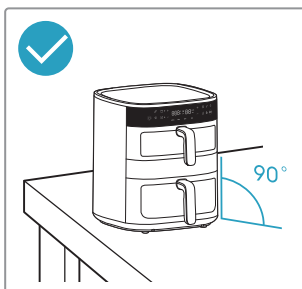
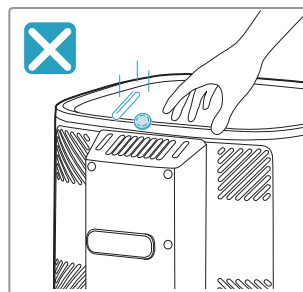
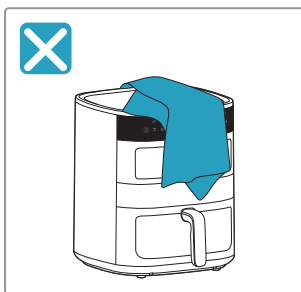





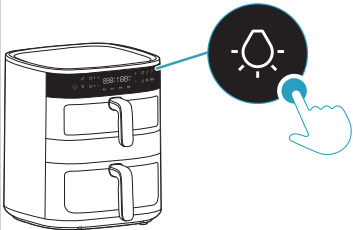
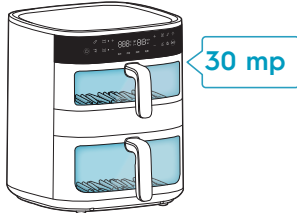
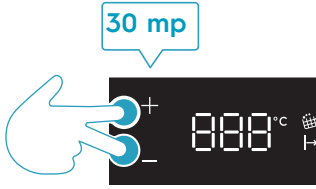
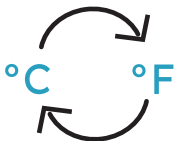









EN
BG
CZ
DE
DK
EE
FI
FR
GR
HR
HU
IT
LT
LV
NO
NL
PL
PT
RO
RU
SE
SI
SK
SR
TR
UA
ES
GE
AL







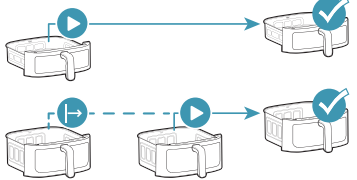







Világítás érintőgomb és hőmérséklet mértékegység váltás

 <p>Világítás érintőgomb</p>		
<p>°C/°F Hőmérséklet mértékegység váltás</p>		

Kosárválasztás

	 4L	 7L	
 Felső kosár			
 Alsó kosár			
 Kapcsolat funkció			
 Szinkronizált befejezés funkció			

Előbeállítás funkció

					
AirFry	180°C	15perc	60-200°C	1-99perc	
	170°C	10perc	60-200°C	1-99perc	
	140°C	15perc	60-200°C	1-99perc	
	180°C	30perc	60-200°C	1-99perc	
	200°C	10perc	60-200°C	1-99perc	
Bake	170°C	15perc	60-200°C	1-99perc	
Grill	200°C	5perc	60-200°C	1-99perc	
Dry	80°C	5óra	40-80°C	1-5óra	

Sütés előtt

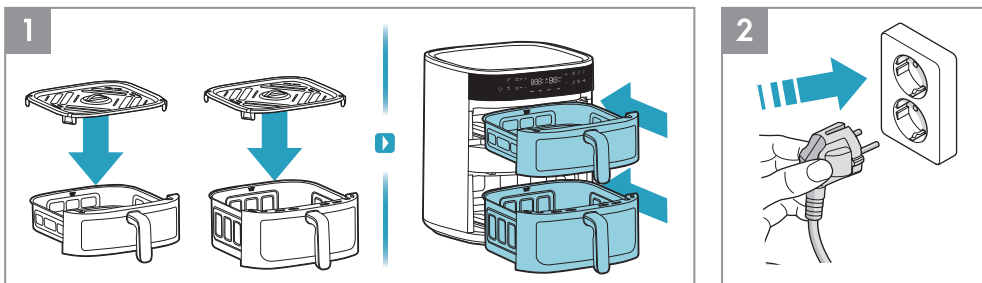

1. Mindegyik sütés előtt tegye a rácsot a kosárba (nem szükséges eltávolítani a rács hőálló szilikon lábtalpat), majd ütközésig nyomja a kosarat a készülékbe.
2. Csatlakoztassa a hálózati kábel csatlakozódugóját egy fali csatlakozóaljzatba.

Használat - egy kosár

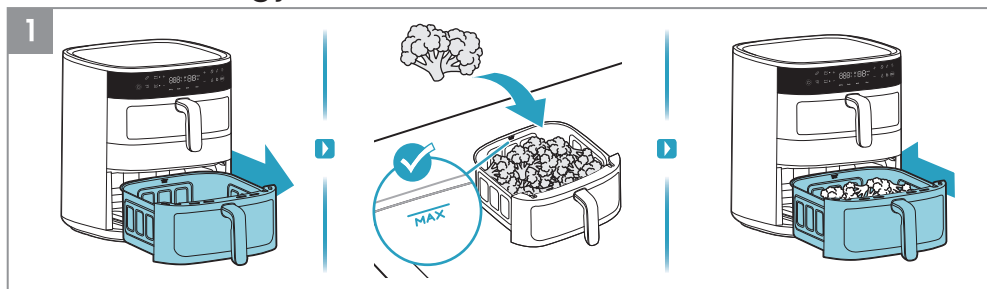

1. Húzza ki az egyik kosarat és tegye egy stabil felületre, "MAX." befogadóképesség jelzésre figyelve tegye az ételt a kosárba. Majd az étellel együtt ütközésig nyomja a kosarat a készülékbe..

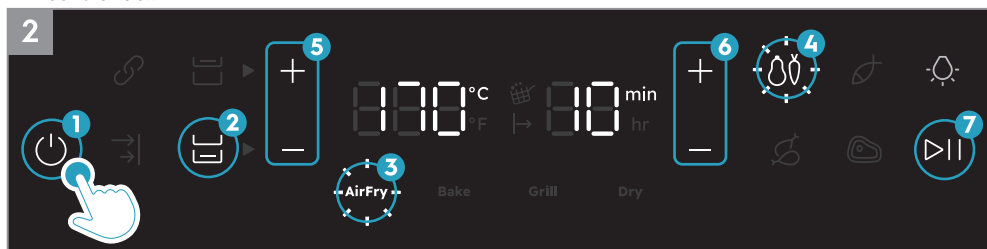

2. Nyomja meg a be/ki gombot. Először válassza ki az ételt tartalmazó kosarat. Majd válassza ki a kívánt elkészítés módszert, pl. forrólevegős sütés funkció. Az ízlésének megfelelően állítsa be az időt és a hőmérsékletet vagy válassza ki az egyik előre beállított receptet, például zöldség. Végül nyomja meg a működés/szünet gombot.

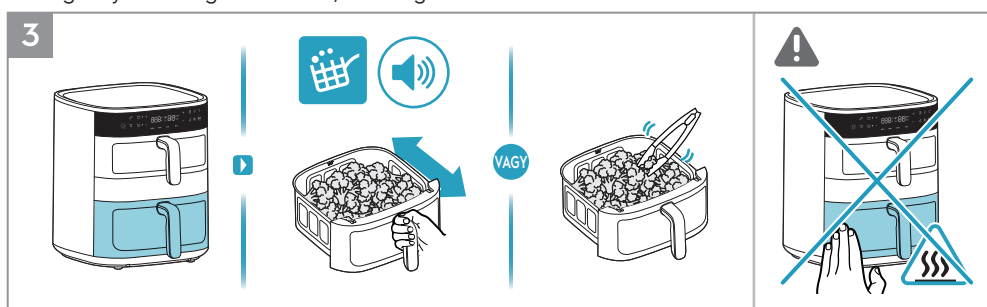

3. Amikor világítani kezd a "Rázási emlékeztető" ikon és sípjelzés hallható a sütési eljárás során, akkor egy hőálló eszköz segítségével fordítsa meg egyszer az ételt vagy körültekintően kissé rázza meg a sütőkosárban lévő ételt.

- ⚠ **VIGYÁZAT:** Ne rázza erőteljesen a sütőkosarat, hogy elkerülje az étel fröcskölését és égési sérülések okozását.
- ⚠ **VIGYÁZAT:** A készülék használata során figyeljen a forró felületekre.

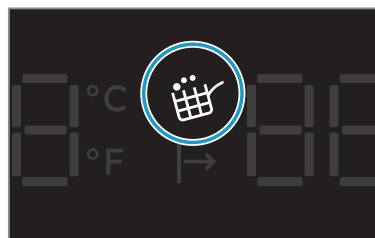

Rázási emlékeztető

A Forrólevegős sütés funkció működése alatt aktiválva van a "Rázási emlékeztető" és az az előre beállított receptek használata, mint pl. Zöldségek, Hal, Csirkecomb és Steak.

Amikor elérkezik az étel rázásának vagy megfordításának az ideje akkor egy percig villog a "Rázási emlékeztető" ikon, továbbá három sípjelzés hallható.

Nem feltétlenül szükséges a "Rázási emlékeztető" figyelembevétele, mivel a szokásos módon folytatódik a sütés, még akkor is nem történt meg az étel megfordítása vagy rázása.



4. A sütési idő leteltével egy sípjelzést ad a készülék. Körültekintően vegye ki a kosarat, majd tegye egy hűálló felületre. A készülék használata után bontsa a hálózati csatlakozását

⚠ **VIGYÁZAT:** Forró gőz léphet ki a kosárból, ha félig kinyitja vagy a sütés végén. A kinyitásokor ügyeljen arra, hogy távol legyen a gőztől az arca, a karja és a keze.

Használat - felső + alsó kosár

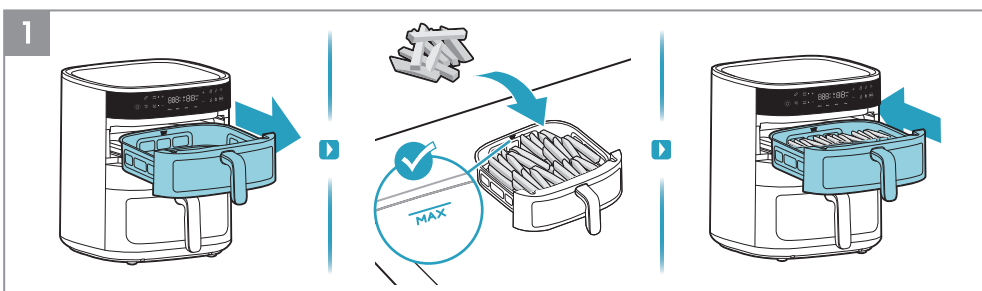

1. Először a felső kosarat húzza ki, tegye az ételt a kosárba, például, sültkrumpli.

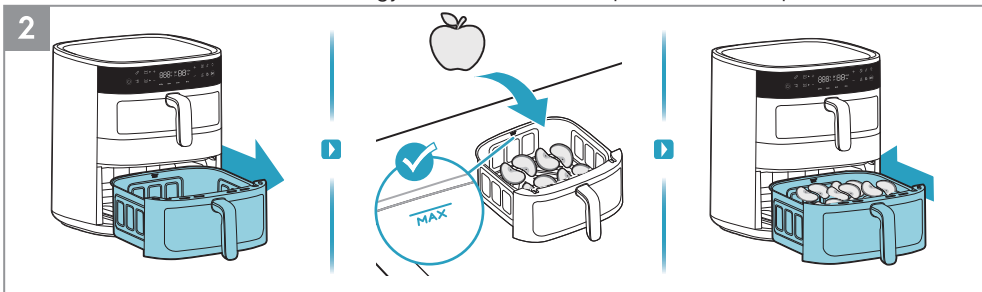

2. Másodszor az alsó kosarat húzza ki, tegye az ételt a kosárba, például, almászeleteket



3. Nyomja meg a be/ki gombot. Először a felső kosarat válassza ki. Majd válassza ki a kívánt elkészítés módszert, pl. forrólevegős sütés funkció. Az ízlésének megfelelően állítsa be az időt és a hőmérsékletet vagy válassza ki az egyik előre beállított receptet, például zöldség. Végül nyomja meg a működés/szünet gombot.

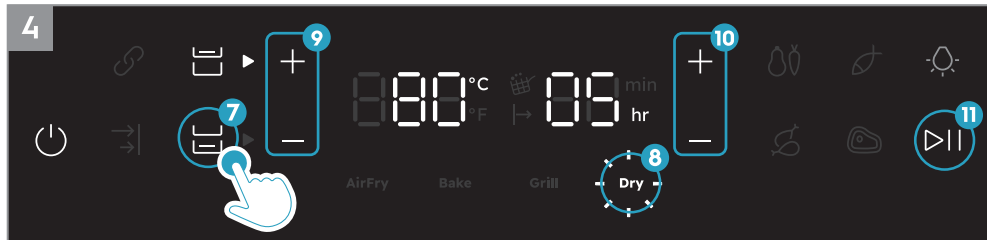

4. Másodszor az alsó kosarat válassza ki. Majd válassza ki a kívánt elkészítés módszert, pl. Aszalás funkció. Az ízlésének megfelelően válassza ki a hőmérsékletet és az időt. Végül nyomja meg a működés/szünet gombot.

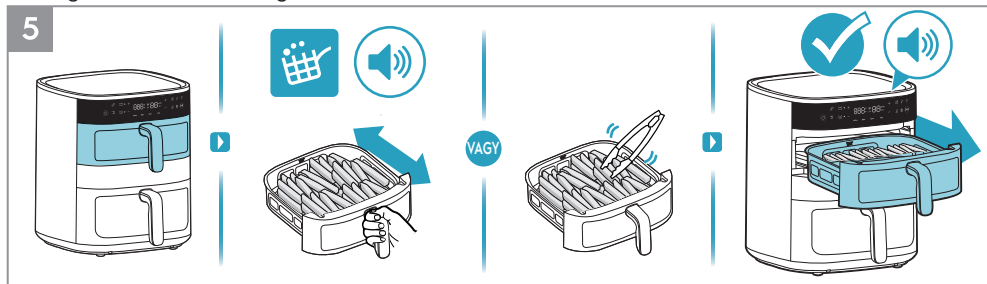

5. Amikor világítani kezd a „Rázási emlékeztető” ikon és sípjelzés hallható a sütési eljárás során, akkor egy hőálló eszköz segítségével fordítsa meg egyszer az ételt vagy körültekintően kissé rázza meg a sütőkosárban lévő ételt. A felső kosár sütési idejének a leteltével egy sípjelzést ad a készülék.

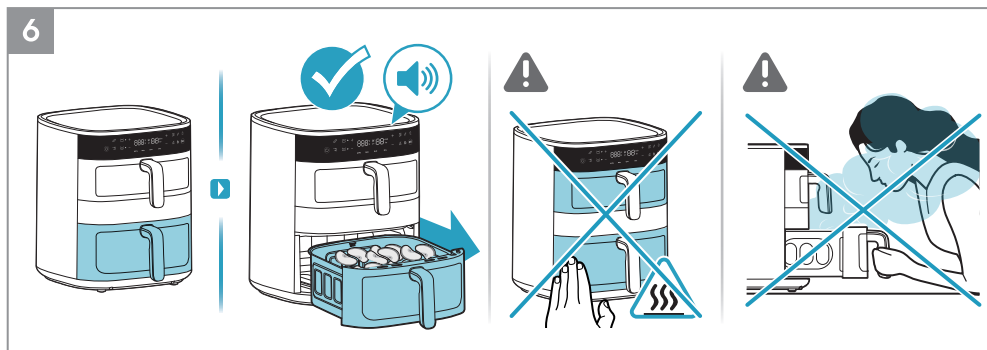

6. Az alsó kosár sütési idejének a leteltével egy sípjelzést ad a készülék.

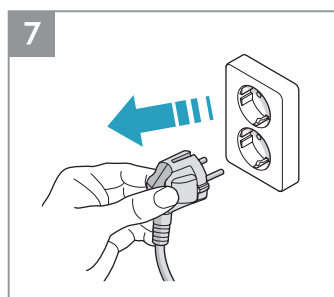

7. A készülék használata után bontsa a hálózati csatlakozását

Használat - Kapcsolat funkció

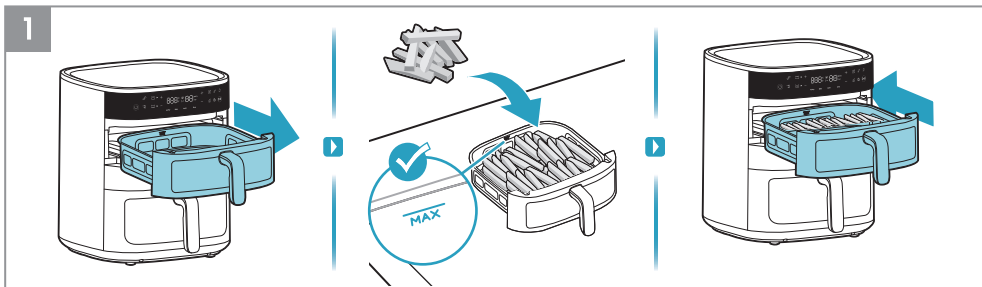

1. Először a felső kosarat húzza ki, tegye az ételt a kosárba, például, sültkrumpli.

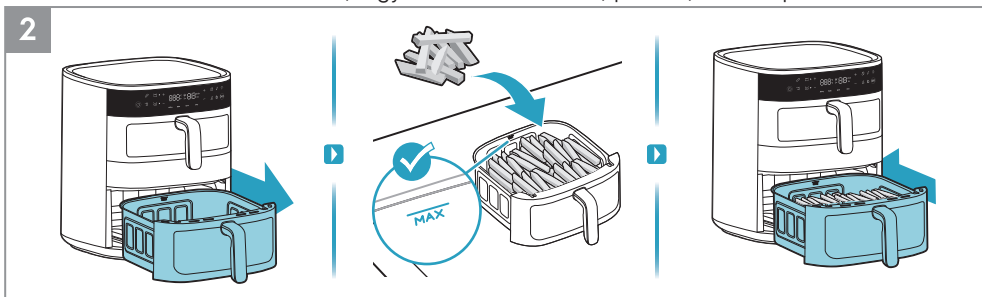

2. Másodszor az alsó kosarat húzza ki, tegye az ételt a kosárba, például, sültkrumpli.

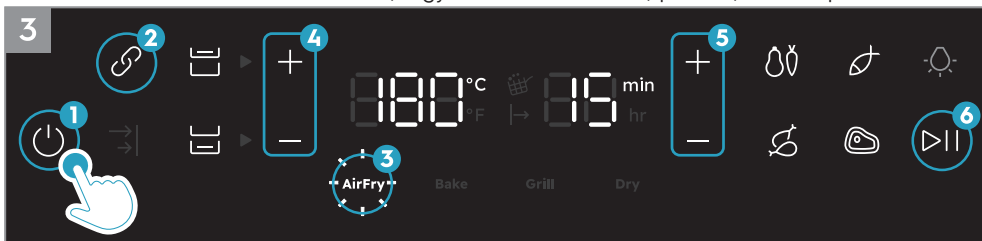

3. Nyomja meg a be/ki gombot. Először válassza ki a Kapcsolat funkciót. Majd válassza ki a kívánt elkészítési módszert, pl. forrólevegős sütés funkciót. Az ízlésének megfelelően állítsa be az időt és a hőmérsékletet vagy válassza ki egyik előre beállított receptet. Végül nyomja meg a működés/szünet gombot.

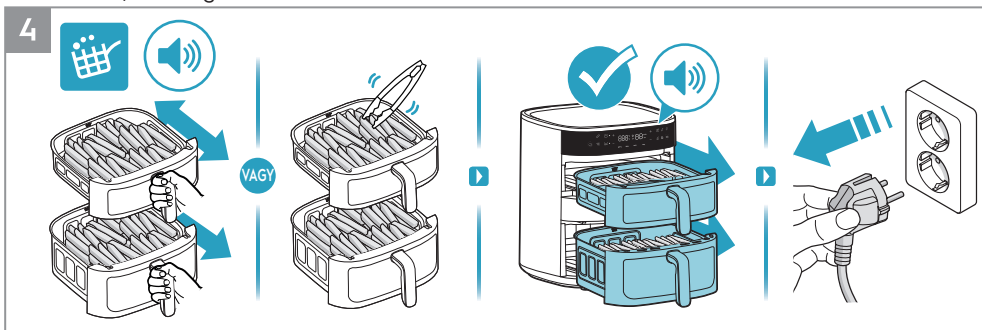

4. Amikor világitani kezd a "Rázási emlékeztető" ikon és sípjelzés hallható a sütési eljárás során, akkor egy hőálló eszköz segítségével fordítsa meg egyszer az ételt vagy körültekintően kissé rázza meg a sütőkosárban lévő ételt. A sütési idő leteltével egy sípjelzést ad a készülék. A készülék használata után bontsa a hálózati csatlakozását.

EN
BG
CZ
DE
DK
EE
FI
FR
GR
HR
HU
IT
LT
LV
NO
NL
PL
PT
RO
RU
SE
SI
SK
SR
TR
UA
ES
GE
AL

Használat - Szinkronizált befejezés funkció

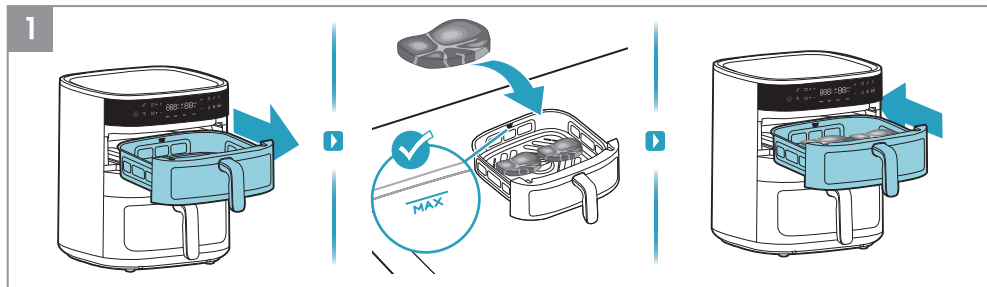

1. Először a felső kosarat húzza ki, tegye az ételt a kosárba, például, steak.

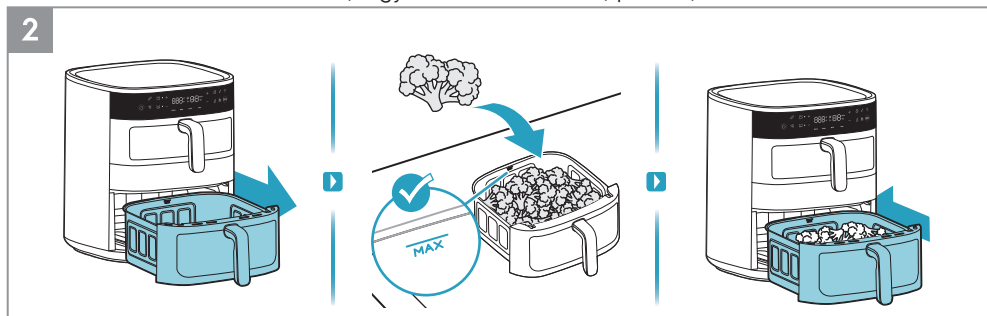

2. Másodsor az alsó kosarat húzza ki, tegye az ételt a kosárba, például, brokkoli.

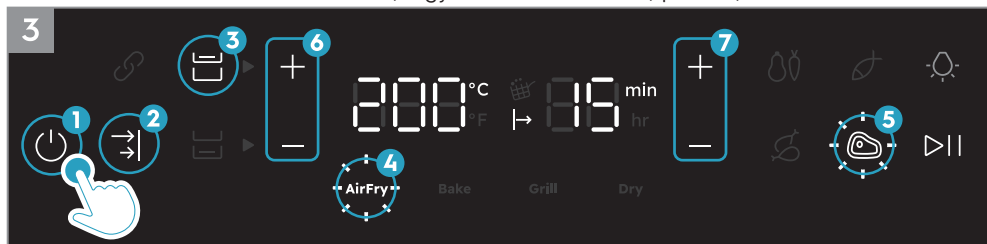

3. Nyomja meg a be/ki gombot. Válassza ki a Szinkronizált befejezés funkciót. Először válassza ki a felső kosarat, majd válassza ki a kívánt elkészítés módszert, pl. forró levegős sütés funkció. Az ízlésének megfelelően állítsa be az időt és a hőmérsékletet vagy válassza ki az egyik előre beállított receptet, például steak.



4. Majd válassza ki az alsó kosarat, válassza ki a kívánt elkészítés módszert, pl. forró levegős sütés funkció. Az ízlésének megfelelően állítsa be az időt és a hőmérsékletet vagy válassza ki az egyik előre beállított receptet. Végül nyomja meg a működés/szünet gombot.

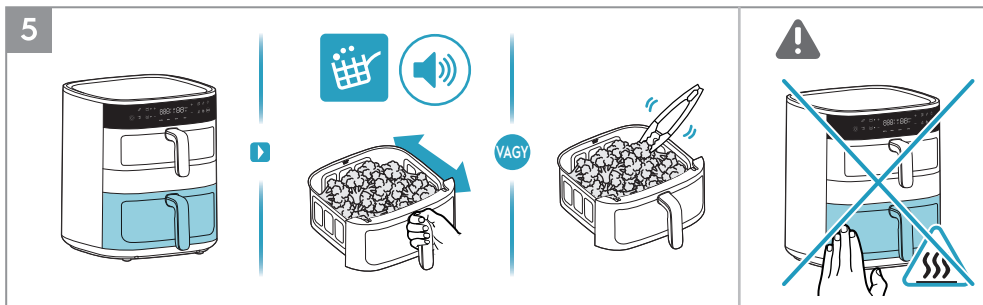

5. Először a hosszabb sütési idejű alsó kosarat részesíti előnybe a sütés során. Amikor világítani kezd a "Rázási emlékeztető" ikon és sípjelzés hallható a sütési eljárás során, akkor egy hőálló eszköz segítségével fordítsa meg egyszer az ételt vagy körültekintően kissé rázza meg a sütőkosárban lévő ételt.

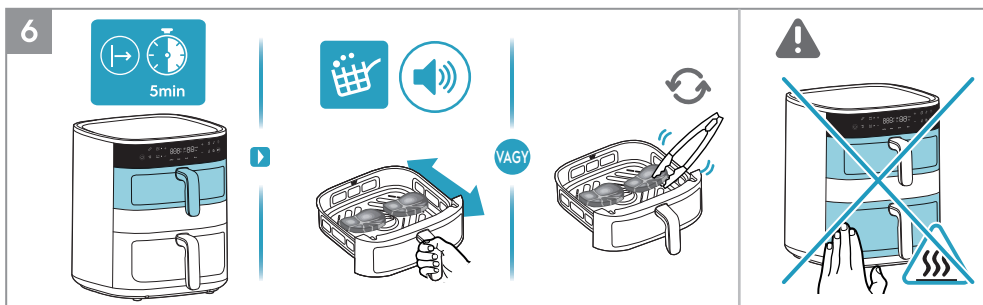

6. Másodszor a rövidebb sütési idejű felső kosár sütését kezdi meg. Amikor világítani kezd a "Rázási emlékeztető" ikon és sípjelzés hallható a sütési eljárás során, akkor egy hőálló eszköz segítségével fordítsa meg egyszer az ételt vagy körültekintően kissé rázza meg a sütőkosárban lévő ételt.

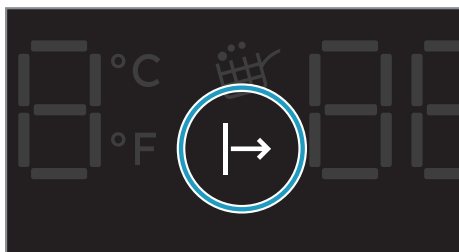

Sütésre várakozás kijelző

Amikor aktiválva van a "Szinkronizált befejezés funkció", akkor a rövidebb sütési idejű kosár egy ideig vár a hosszabb sütési idejű kosárra, hogy egyszerre fejeződhessen be mindkét kosárban a sütés. Ezen idő alatt a sütés megkezdéséig világít a "sütésre várakozás kijelző".

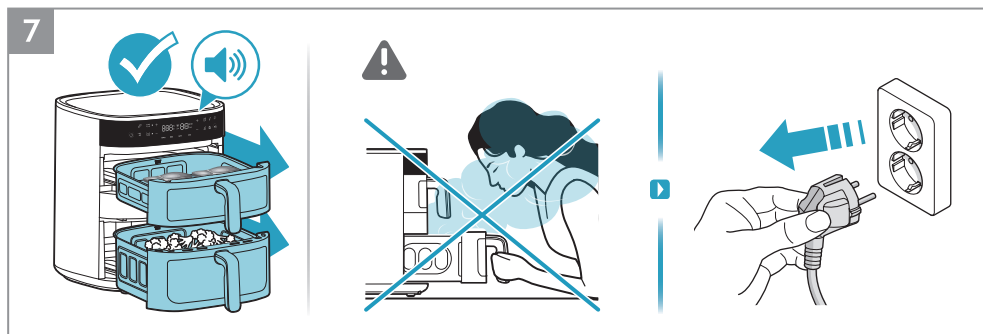

7. A sütési idő leteltével egy sípjelzést ad a készülék. A készülék használata után bontsa a hálózati csatlakozását.

Tisztítás

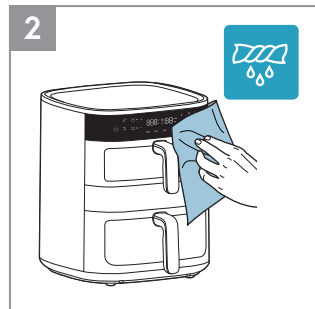
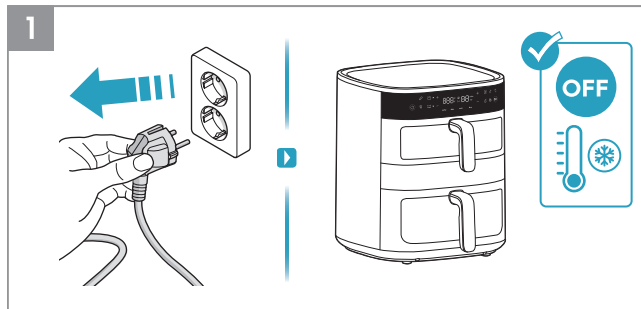

1. Mindig bontsa a készülék hálózati csatlakozását, és a tisztítás előtt várja meg, amíg az lehül.
2. Egy puha kendővel törölje le a készülék külsejét.

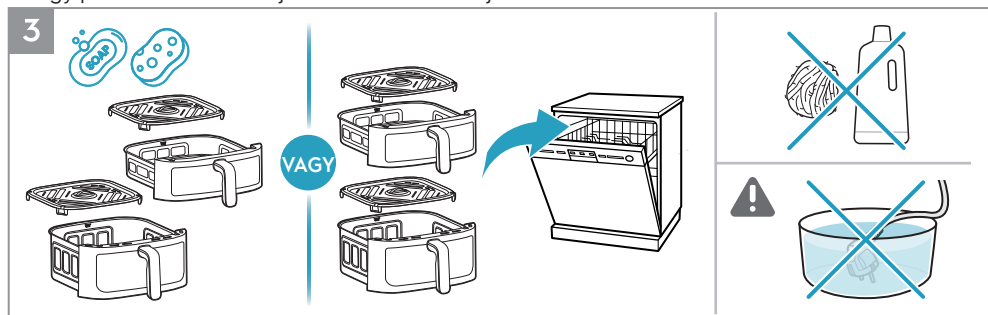

3. Meleg mosogatószeres vízzel tisztítsa meg a serpenyőt és a rácsot vagy tegye azokat mosogatógépbe.

▲MEGJEGYZÉS: Kerülje a dörzsölő tisztítószeres vagy fémeszközök használatát, hogy védje a letapadástól mentes bevonatot



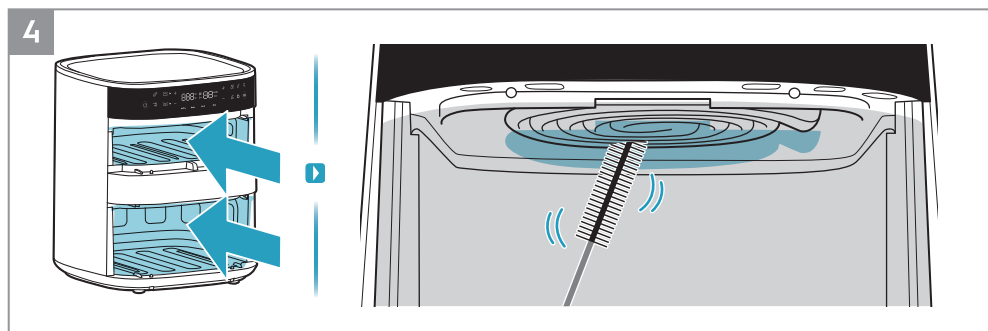









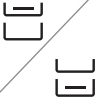

























VIGYÁZAT: Sohase merítse a készüléket, a kábelt vagy a csatlakozódugót vízbe vagy bármilyen más folyadékba.



4. Egy tisztítókefével tisztítsa meg a fűtőelemeket

























MEGJEGYZÉS: A fűtőelemek tisztítása előtt biztosítsa, hogy teljesen lehűljön a készülék.

Sütési útmutató

							
AirFry	7mm/10mm 	4L 	400g	180°C	18perc		
		7L 	400g	180°C	18perc		
AirFry		4L 	400g	170°C	8perc		
		7L 	400g	170°C	10perc		
AirFry		4L 	400g/2pcs	140°C	15perc		
		7L 	400g/2db	140°C	15perc		
AirFry		4L 	1000g/8db	180°C	28perc		
		7L 	1000g/8db	180°C	28perc		
AirFry		4L 	400g/2db	200°C	10perc		
		7L 	400g/2db	200°C	10perc		
AirFry		4L 	220g/6hüvelyk	160°C	12perc		
		7L 	220g/6hüvelyk	160°C	14perc		

EN
BG
CZ
DE
DK
EE
FI
FR
GR
HR
HU
IT
LT
LV
NO
NL
PL
PT
RO
RU
SE
SI
SK
SR
TR
UA
ES
GE
AL

EN
BG
CZ
DE
DK
EE
FI
FR
GR
HR
HU
IT
LT
LV
NO
NL
PL
PT
RO
RU
SE
SI
SK
SR
TR
UA
ES
GE
AL

							
AirFry		7L 	1200g	180°C	55perc		
AirFry		7L 	400g/9db	160°C	20perc		
Grill		4L 	180g/4db	180°C	8perc		
HU		7L 	180g/4db	180°C	9perc		
Dry		4L 	180g	80°C	3óra		
Dry		7L 	180g	80°C	3óra		
Dry		4L 	200g	80°C	3óra		
Dry		7L 	200g	80°C	3óra		

A teendő, ha...

Probléma	Ellenőrizze, hogy...
Nem tudja bekapcsolni vagy működtetni a készüléket	<ul style="list-style-type: none"> • Megfelelően van csatlakoztatva a készülék egy hálózati csatlakozóaljzathoz. • Helyesen vannak a kosarak a készülékbe rakva. A feszültségellátás biztosítása érdekében ügyeljen arra, hogy teljesen be legyenek nyomva a készülékbe. • Be van állítva a sütési idő.
Nem tudta betolni a kosarat a készülékbe.	<ul style="list-style-type: none"> • A kosár maximális befogadóképességénél több van betöltve. • Helyesen van betéve a kosár. Kattanást kell hallania, amikor beteszi az egységbe. • Egy tárgy van a kosár alatt, ami akadályozza a megfelelő zárását.
Fehér füst száll ki a készülékből.	<ul style="list-style-type: none"> • Túl zsíros a készítenő étel. • Tiszta a kosár, rács és a fűtőelem.
E1 kijelzés látható a kijelzőn.	• Felső kosárnál szakadás van.
E2 kijelzés látható a kijelzőn.	• Felső kosárnál zárlat van.
E3 kijelzés látható a kijelzőn.	• Alsó kosárnál szakadás van.
E4 kijelzés látható a kijelzőn.	• Alsó kosárnál zárlat van.
E5 kijelzés látható a kijelzőn.	• Kezelőszerv PCBA kommunikációs hiba.
E6 kijelzés látható a kijelzőn.	• Tápellátás PCBA kommunikációs hiba.

* Ha hibakód jelenik meg a kijelzőn, akkor egy szervizben kell megjavíttatni a készüléket.

Műszaki adatok

Termék	Forrólevegős sütő
Modell	EAFD11B
Feszültség (V-)	220 V - 240 V
Teljesítmény (W)	2700 W
Frekvencia (Hz)	50 - 60 Hz
Befogadóképesség	4 l + 7 l

EN

BG

CZ

DE

DK

EE

FI

FR

GR

HR

HU

IT

LT

LV

NO

NL

PL

PT

RO

RU

SE

SI

SK

SR

TR

UA

ES

GE

AL



Manuale di istruzioni

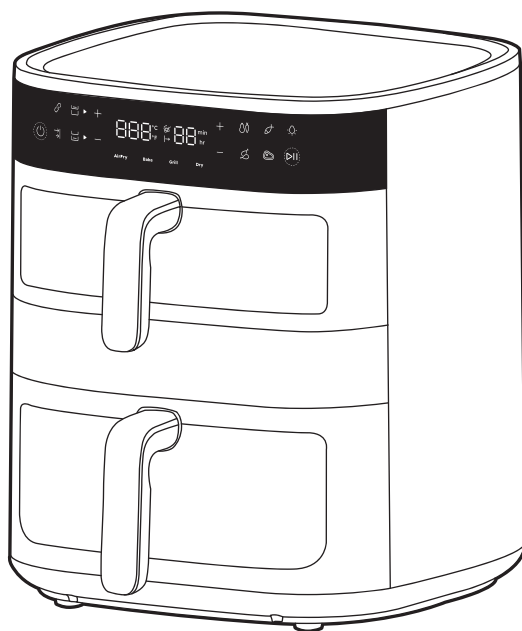

Friggitrice ad aria doppia 800

Panoramica generale

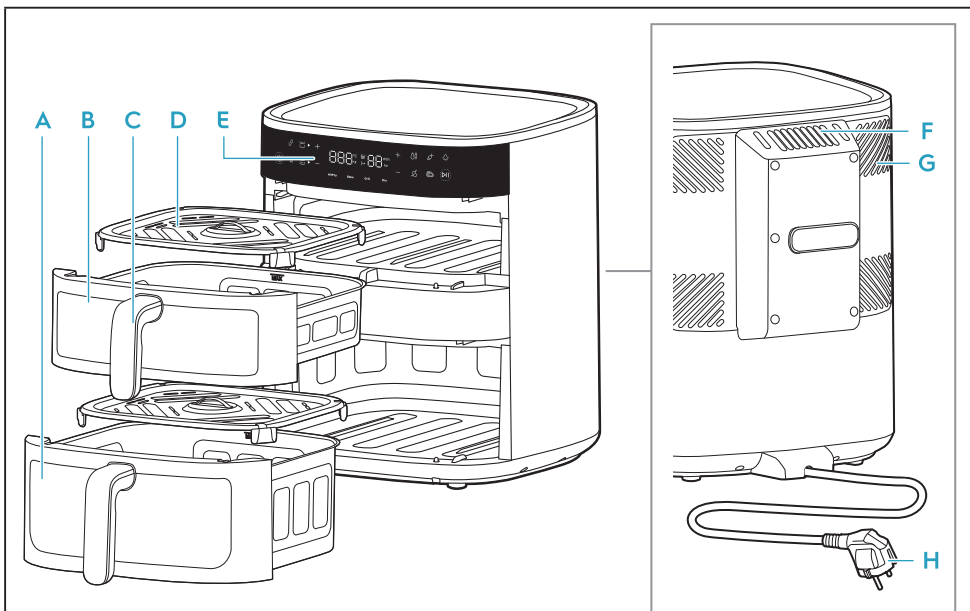

- | | | | |
|----------------------------------|--------------------------------|--------------------------------|------------------------------------|
| A Cestello inferiore (7L) | C Maniglia del cestello | E Pannello di controllo | G Sistema di raffreddamento |
| B Cestello superiore (4L) | D Griglia | F Presa d'aria | H Cavo di alimentazione |

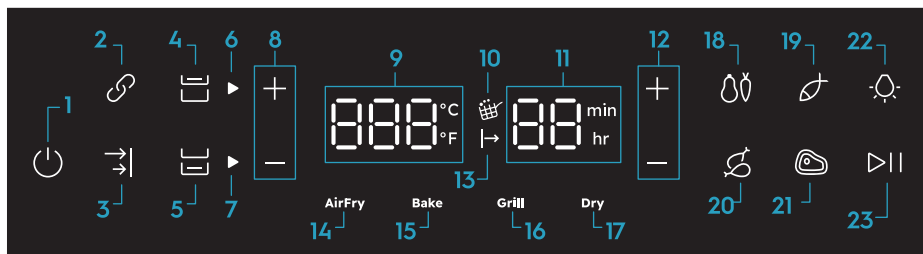

- | | | | |
|--------------------------------------|--|---|---------------------------|
| 1. On/Off | 7. Indicatore cestello inferiore | 11. Indicatore del tempo (AirFry: 1-99 min, Disidratata: 1- 5h) | 17. Funzione essiccazione |
| 2. Funzione Link | 8. Controllo della temperatura | 12. Controllo del tempo | 18. Verdure |
| 3. Funzione di fine sincronizzazione | 9. Indicatore della temperatura (40-200°C) | 13. In attesa di cottura | 19. Pesce |
| 4. Controllo cestello superiore | 10. Promemoria agitazione | 14. Funzione AirFry | 20. Pollo |
| 5. Controllo cestello inferiore | | 15. Funzione cottura al forno | 21. Bistecca |
| 6. Indicatore cestello superiore | | 16. Funzione grill | 22. Controllo luce |
| | | | 23. Riproduzione/ Pausa |

Prima del primo utilizzo

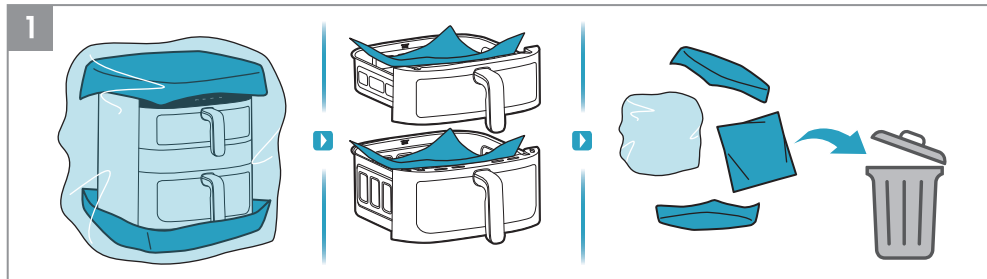

1. Rimuovere tutto l'imballaggio e il materiale protettivo.

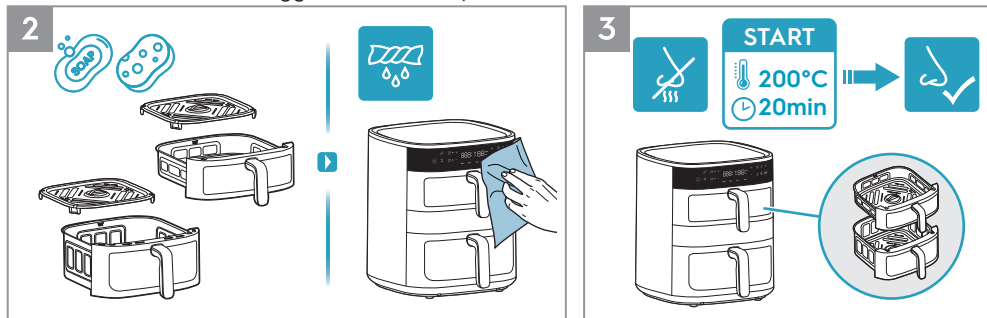

2. Pulire la teglia e la griglia con acqua tiepida e detersivo per piatti. Pulire l'interno e l'esterno dell'apparecchio con un panno morbido.

3. È normale che un'unità nuova emetta odori durante le prime volte che viene utilizzata. Per evitare questo problema, far funzionare la friggitrice ad aria vuota a 200 °C per 20 minuti prima del primo utilizzo.



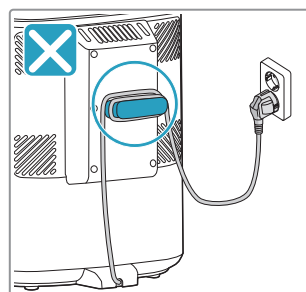
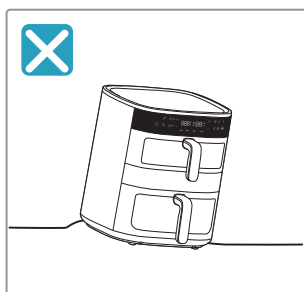
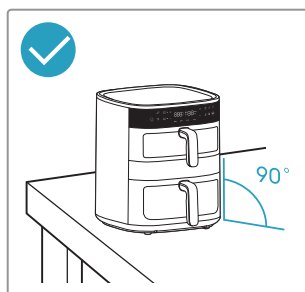
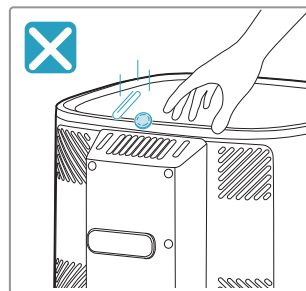
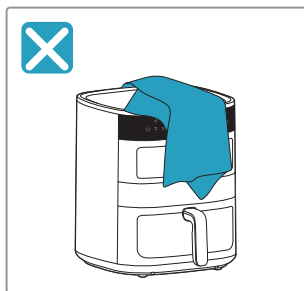
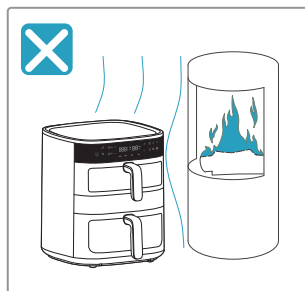



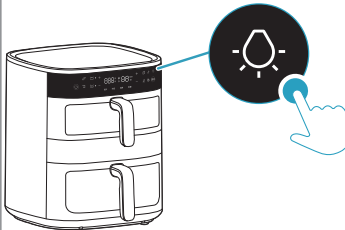
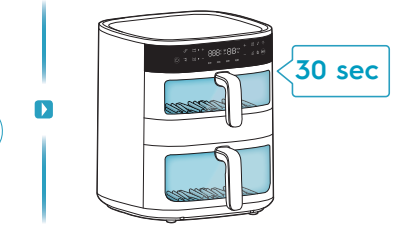
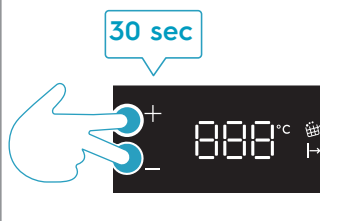
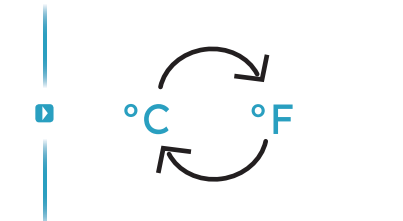







! Precauzioni di sicurezza









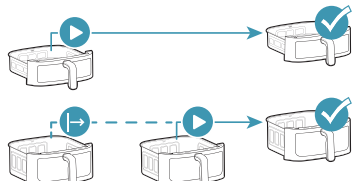



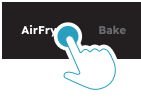



Controllo dell'illuminazione e conversione della scala di temperatura

 <p>Controllo dell'illuminazione</p>		
<p>°C/°F</p> <p>Conversione della scala di temperatura</p>		

Selezione del cestello

	 <p>4L</p>	 <p>7L</p>	
 <p>Cestello superiore</p>			
 <p>Cestello inferiore</p>			
 <p>Funzione Link</p>			
 <p>Funzione di fine sincronizzazione</p>			

Funzioni preimpostate

					
Air Fry	180°C	15min	60-200°C	1-99min	
	170°C	10min	60-200°C	1-99min	
	140°C	15min	60-200°C	1-99min	
	180°C	30min	60-200°C	1-99min	
	200°C	10min	60-200°C	1-99min	
Bake	170°C	15min	60-200°C	1-99min	
Grill	200°C	5min	60-200°C	1-99min	
Dry	80°C	5h	40-80°C	1-5h	

Prima della cottura

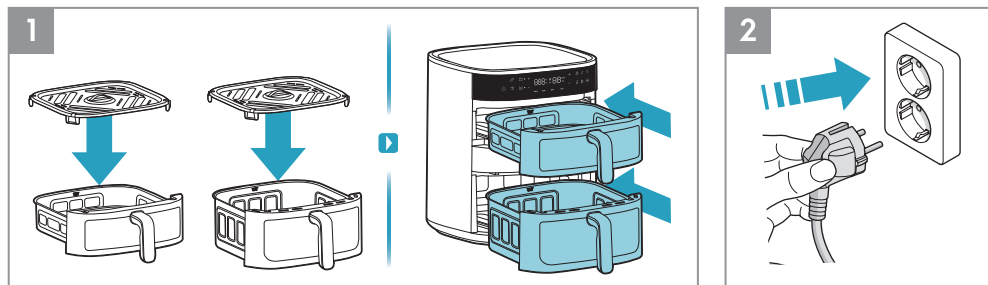

1. Prima di ogni cottura, posizionare la griglia nel cestello (non è necessario rimuovere il piedino in silicone resistente al calore della griglia) e spingere completamente il cestello nell'apparecchio.
2. Inserire la spina di alimentazione dalla presa di corrente.

Modalità d'uso - Cestello singolo

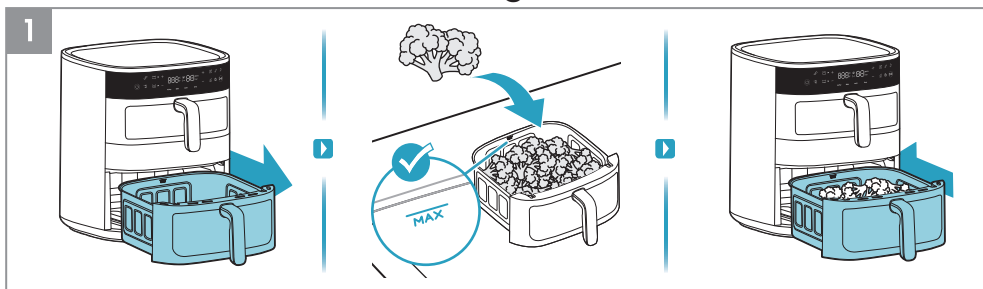

1. Estrarre un cestello e posizionarlo su una superficie stabile, inserire il cibo nel cestello, osservando l'indicazione di capacità "MAX". Quindi spingere completamente il cestello con il cibo all'interno dell'apparecchio.



2. Premere il pulsante On/Off. Selezionare prima il cestello con il cibo. Quindi selezionare il metodo di cottura desiderato, ad esempio la funzione Air Fry. Regola il tempo e la temperatura a tuo piacimento o seleziona una delle ricette preimpostate, ad esempio Verdure. Infine, premi il pulsante Riproduzione/Pausa.

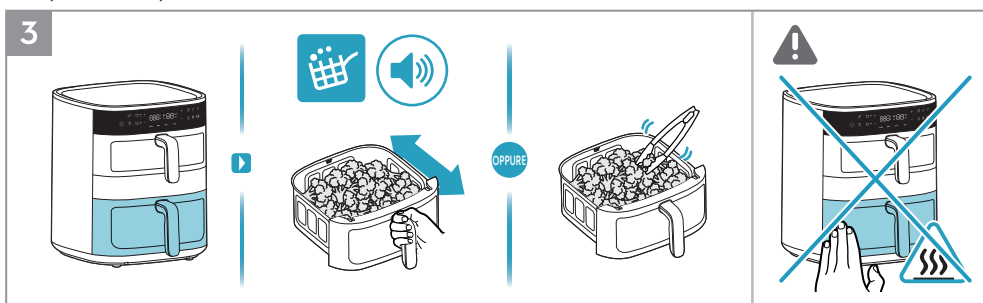

3. Quando l'icona "Promemoria agitazione" si illumina ed emette un segnale acustico durante la cottura, utilizza utensili resistenti al calore per girare il cibo una volta o agitalo leggermente con attenzione nel cestello.

- ⚠ **AVVERTENZA:** Non agitare energicamente il cestello per evitare schizzi di cibo e ustioni.
- ⚠ **AVVERTENZA:** Prestare attenzione alle superfici calde quando l'apparecchio è in funzione.

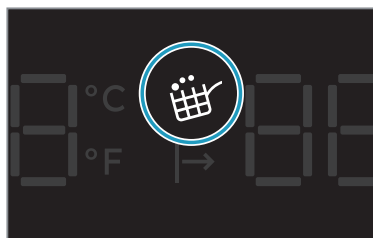

Promemoria agitazione

La funzione "Promemoria agitazione" si attiva durante la funzione Air Fry e le ricette preimpostate, come Verdure, Pesce, Cosce di pollo e Bistecca.

Quando è il momento di agitare o girare il cibo, l'icona "Promemoria agitazione" si illumina e lampeggia per un minuto, mentre un segnale acustico viene ripetuto per tre volte.

La funzione "Promemoria agitazione" non è obbligatoria, quindi la cottura continuerà normalmente anche se il cibo non viene girato o agitato.



4. Al termine della cottura, l'apparecchio emetterà un segnale acustico. Rimuovere con cautela il cestello e posizionarlo su una superficie resistente al calore. Scollegare l'apparecchio dopo l'uso.

⚠ **AVVERTENZA:** Dal cestello può fuoriuscire vapore caldo quando viene aperto a metà o alla fine della cottura. Assicurarsi che viso, braccia e mani siano lontani dal vapore quando lo si apre.

Modalità d'uso - Cestello superiore + inferiore

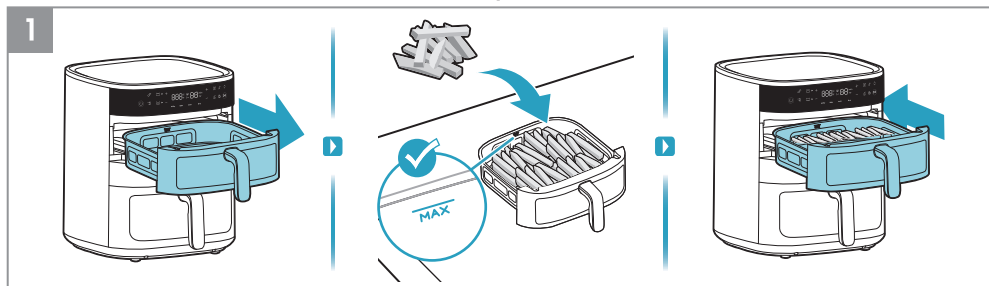

1. Innanzitutto, estrarre il cestello superiore e inserire il cibo, ad esempio patatine fritte.

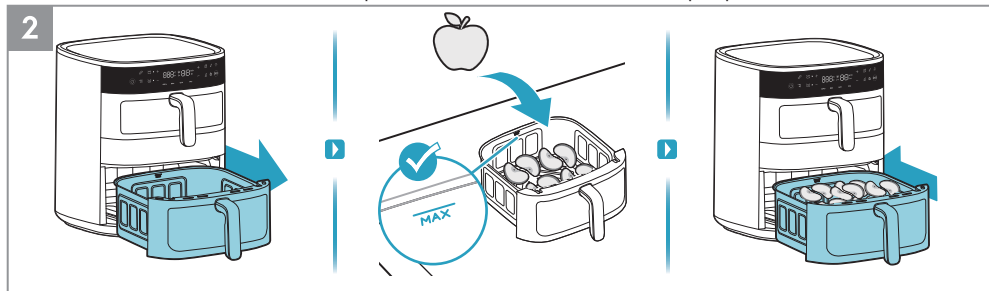

2. In secondo luogo, estrarre il cestello inferiore e inserire il cibo, ad esempio fette di mela.



3. Premere il pulsante On/Off. Selezionare prima il cestello superiore. Quindi selezionare il metodo di cottura desiderato, ad esempio la funzione Air Fry. Regola il tempo e la temperatura a tuo piacimento o seleziona una delle ricette preimpostate, ad esempio Verdure. Infine, premi il pulsante Riproduzione/Pausa.



4. Selezionare poi il cestello inferiore. Quindi selezionare il metodo di cottura desiderato, ad esempio la funzione Essiccazione. Regola il tempo e la temperatura a tuo piacimento. Infine, premi il pulsante Riproduzione/Pausa.

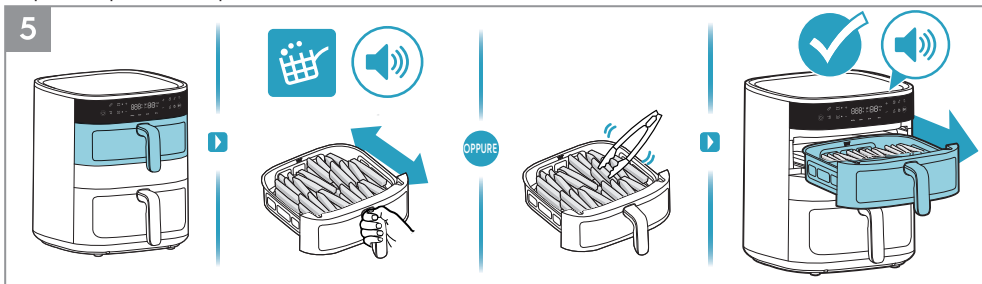

5. Quando l'icona "Promemoria agitazione" si illumina ed emette un segnale acustico durante la cottura, utilizza utensili resistenti al calore per girare il cibo una volta o agitalo leggermente con attenzione nel cestello. Al termine del tempo di cottura del cestello superiore, l'apparecchio emetterà un segnale acustico.

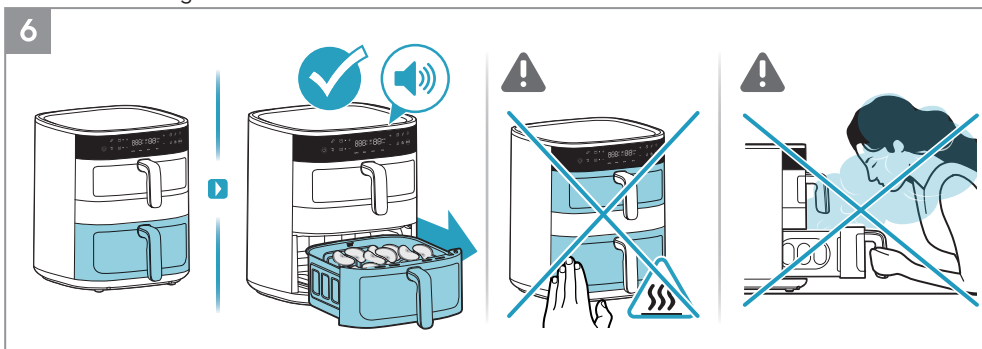

6. Al termine del tempo di cottura del cestello inferiore, l'apparecchio emetterà un segnale acustico.

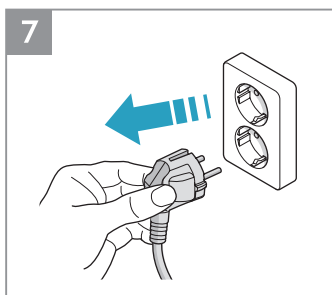

7. Scollegare l'apparecchio dopo l'uso.

EN
BG
CZ
DE
DK
EE
FI
FR
GR
HR
HU
IT
LT
LV
NO
NL
PL
PT
RO
RU
SE
SI
SK
SR
TR
UA
ES
GE
AL

Modalità d'uso - Funzione Link

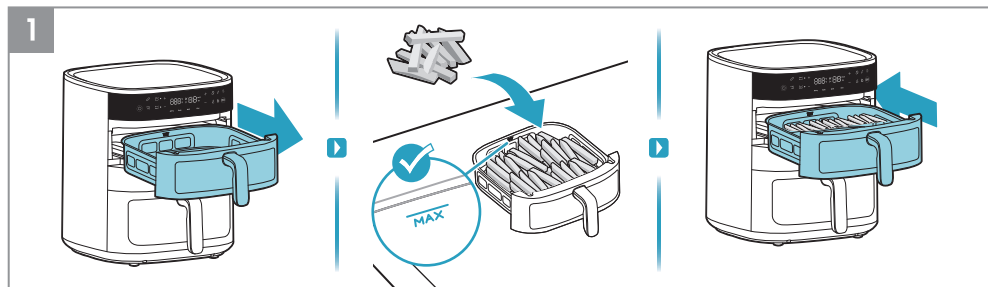

1. Innanzitutto, estrarre il cestello superiore e inserire il cibo, ad esempio patatine fritte.

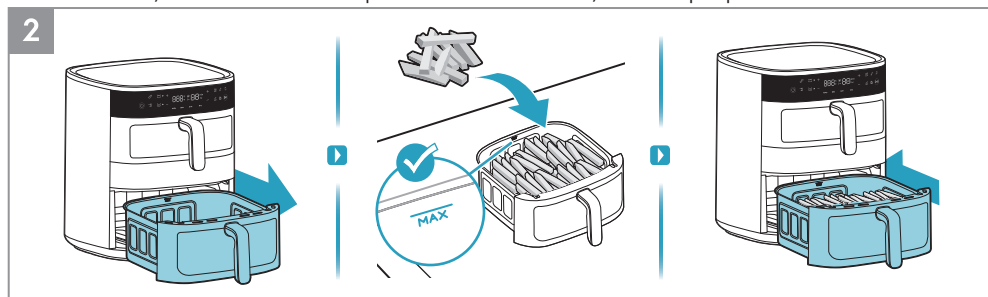

2. In secondo luogo, estrarre il cestello inferiore e inserire il cibo, ad esempio patatine fritte.

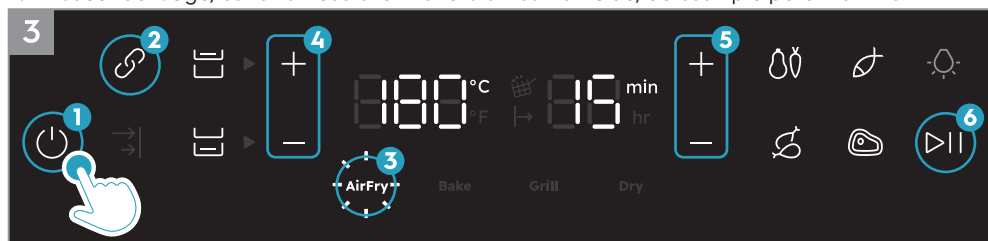

3. Premere il pulsante On/Off. Seleziona prima la funzione Link. Quindi selezionare il metodo di cottura desiderato, ad esempio la funzione Air Fry. Regola il tempo e la temperatura a tuo piacimento o seleziona una delle ricette preimpostate. Infine, premi il pulsante Riproduzione/Pausa.

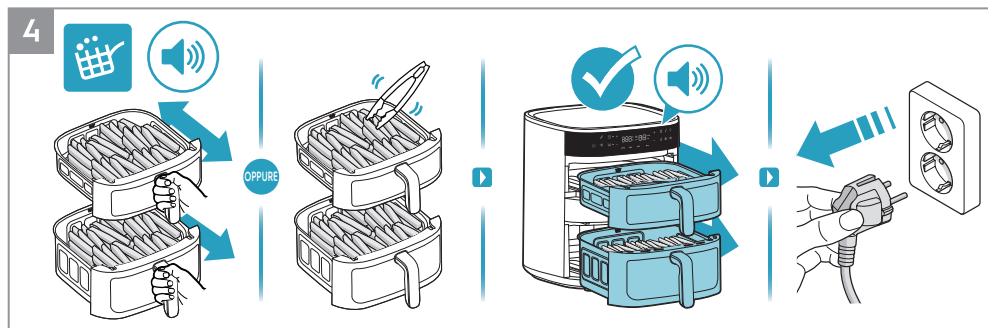

4. Quando l'icona "Promemoria agitazione" si illumina ed emette un segnale acustico durante la cottura, utilizza utensili resistenti al calore per girare il cibo una volta o agitalo leggermente con attenzione nel cestello. Al termine della cottura, l'apparecchio emetterà un segnale acustico. Scollegare l'apparecchio dopo l'uso.

Modalità d'uso - Funzione di fine sincronizzazione

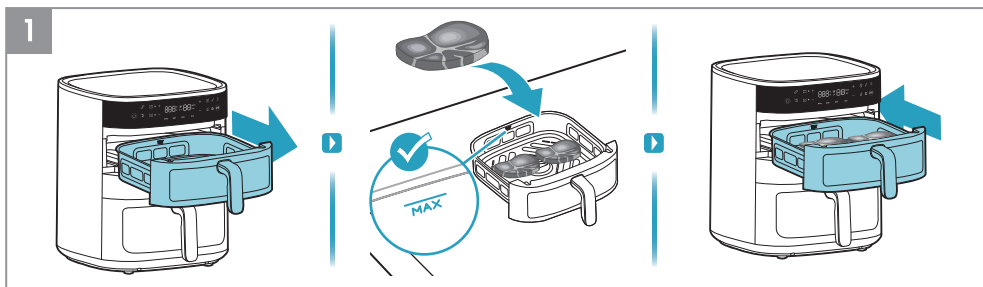

1. Innanzitutto, estrarre il cestello superiore e inserire il cibo, ad esempio bistecca.

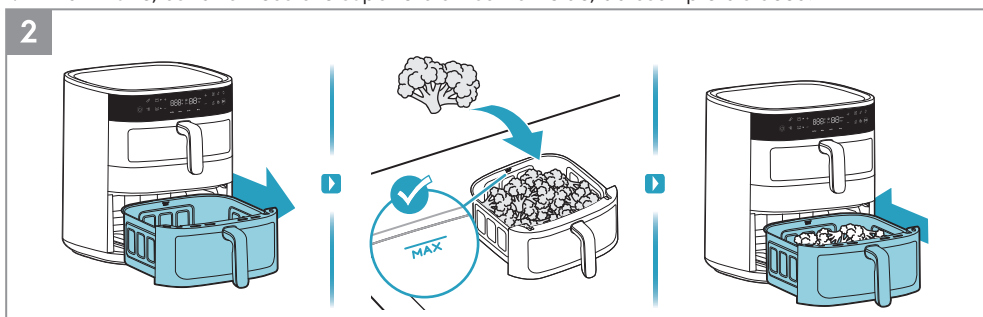

2. In secondo luogo, estrarre il cestello inferiore e inserire il cibo, ad esempio broccoli.



3. Premere il pulsante On/Off. Selezionare la Funzione di fine sincronizzazione. Selezionare prima il cestello superiore, quindi il metodo di cottura desiderato, ad esempio la funzione Air Fry. Regola il tempo e la temperatura a tuo piacimento o seleziona una delle ricette preimpostate, ad esempio Bistecca.



4. Quindi selezionare il cestello inferiore, quindi il metodo di cottura desiderato, ad esempio la funzione Air Fry. Regola il tempo e la temperatura a tuo piacimento o seleziona una delle ricette preimpostate. Infine, premi il pulsante Riproduzione/Pausa.

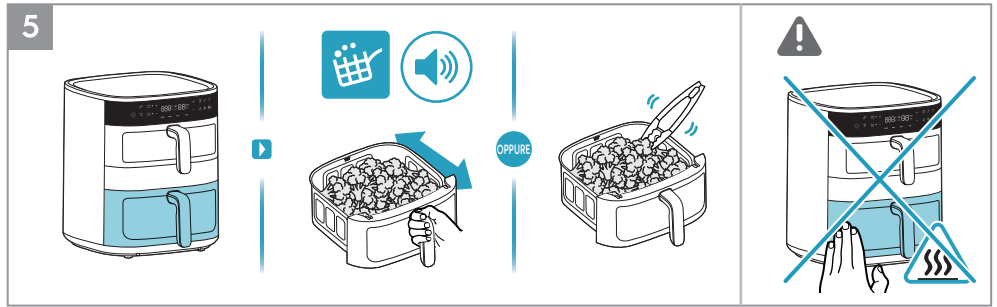

5. Innanzitutto, il cestello inferiore con il tempo di cottura più lungo avrà la priorità per la cottura. Quando l'icona "Promemoria agitazione" si illumina ed emette un segnale acustico durante la cottura, utilizza utensili resistenti al calore per girare il cibo una volta o agitalo leggermente con attenzione nel cestello.

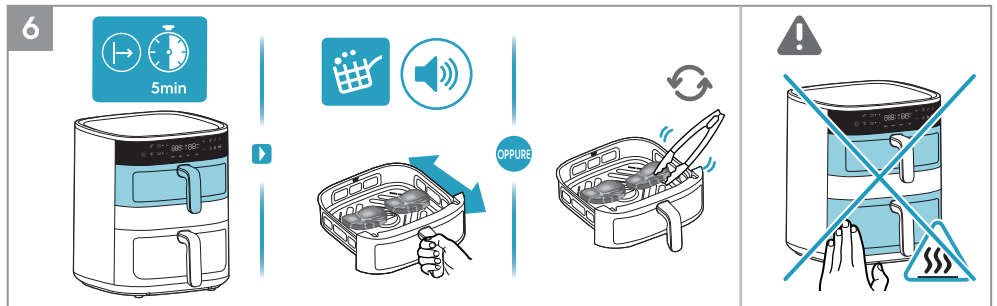

6. In secondo luogo, il cestello superiore con il tempo di cottura più breve inizierà la cottura. Quando l'icona "Promemoria agitazione" si illumina ed emette un segnale acustico durante la cottura, utilizza utensili resistenti al calore per girare il cibo una volta o agitalo leggermente con attenzione nel cestello.

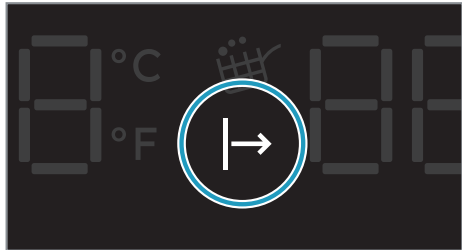

Indicatore di in attesa di cottura

Quando la "Funzione di fine sincronizzazione" è attivata, il cestello con il tempo di cottura più breve attenderà la cottura fino a quando il cestello con il tempo di cottura più lungo non avrà terminato la cottura per un po', in modo che entrambi i cestelli possano terminare la cottura contemporaneamente. Durante questo periodo, l'"indicatore di in attesa di cottura" si illuminerà fino all'inizio della cottura.



7. Al termine della cottura, l'apparecchio emetterà un segnale acustico. Scollegare l'apparecchio dopo l'uso.

Pulizia

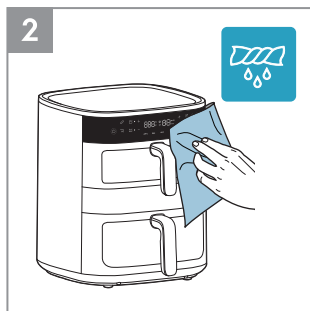
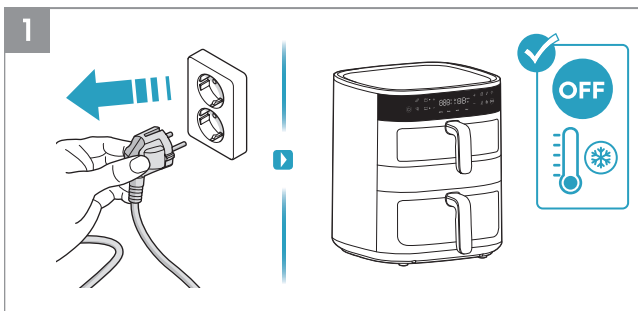

1. Scollegare sempre l'apparecchio e attendere che si raffreddi prima di pulirlo.
2. Pulire l'esterno dell'apparecchio con un panno morbido.

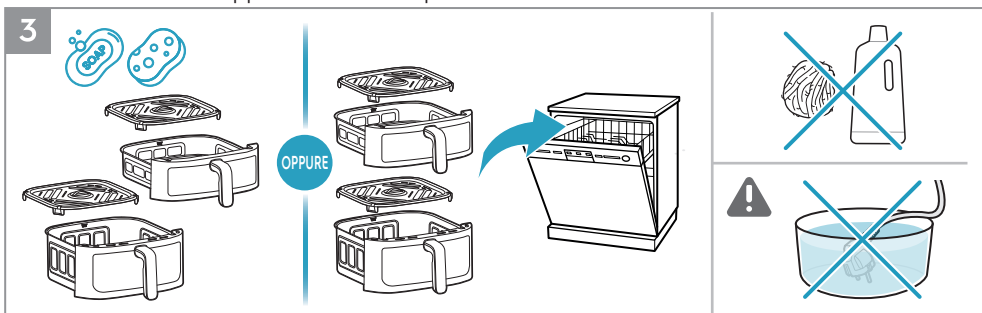

3. Pulire la pentola e la griglia con acqua tiepida e detersivo per piatti, oppure lavarle in lavastoviglie.

▲NOTA: Evitare l'uso di prodotti abrasivi o utensili metallici per proteggere il rivestimento antiaderente.

AVVERTENZA: Non immergere mai il prodotto, il cavo o la spina in acqua o altri liquidi.

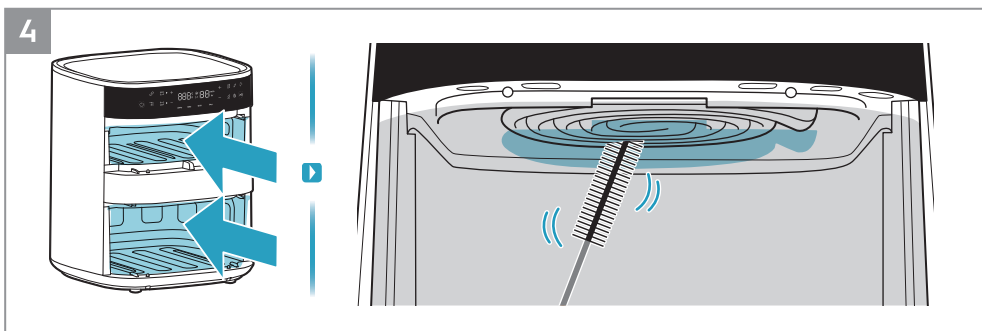











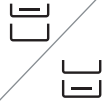

















































4. Pulire l'elemento riscaldante con una spazzola.

NOTA: Assicurarsi che l'apparecchio si sia completamente raffreddato prima di pulire l'elemento riscaldante.

EN
BG
CZ
DE
DK
EE
FI
FR
GR
HR
HU
IT
LT
LV
NO
NL
PL
PT
RO
RU
SE
SI
SK
SR
TR
UA
ES
GE
AL

Guida alla cottura

							
AirFry	7mm/10mm 	4L 	400g	180°C	18min		
		7L 	400g	180°C	18min		
AirFry		4L 	400g	170°C	8min		
		7L 	400g	170°C	10min		
AirFry		4L 	400g/2pz	140°C	15min		
		7L 	400g/2pz	140°C	15min		
AirFry		4L 	1000g/8pz	180°C	28min		
		7L 	1000g/8pz	180°C	28min		
AirFry		4L 	400g/2pz	200°C	10min		
		7L 	400g/2pz	200°C	10min		
AirFry		4L 	220g/6inches	160°C	12min		
		7L 	220g/6inches	160°C	14min		

Recipe							
AirFry		 7L	1200g	180°C	55min		
AirFry		 7L	400g/9pz	160°C	20min		
Grill		 4L	180g/4pz	180°C	8min		
		 7L	180g/4pz	180°C	9min		
Dry		 4L	180g	80°C	3h		
		 7L	180g	80°C	3h		
Dry		 4L	200g	80°C	3h		
		 7L	200g	80°C	3h		

- EN
- BG
- CZ
- DE
- DK
- EE
- FI
- FR
- GR
- HR
- HU
- IT**
- LT
- LV
- NO
- NL
- PL
- PT
- RO
- RU
- SE
- SI
- SK
- SR
- TR
- UA
- ES
- GE
- AL

Cosa fare se...

Problema	Controllare se...
Non è possibile accendere o far funzionare l'apparecchio.	<ul style="list-style-type: none"> • L'apparecchio è correttamente collegato alla rete elettrica. • I cestelli sono nella posizione corretta. Assicurarsi che siano completamente inseriti nell'apparecchio per consentire l'alimentazione elettrica. • Il tempo di cottura è impostato.
Non è possibile inserire il cestello nell'apparecchio.	<ul style="list-style-type: none"> • Il cestello è riempito oltre la sua capacità massima. • Il cestello è posizionato correttamente. Deve scattare quando lo si inserisce nell'unità. • C'è un oggetto sotto il cestello che impedisce la corretta chiusura.
Dall'apparecchio fuoriesce fumo bianco.	<ul style="list-style-type: none"> • Il cibo preparato è troppo unto. • Il cestello, la griglia e l'elemento riscaldante sono puliti.
Il display visualizza E1	• Circuito aperto nel cestello superiore.
Il display visualizza E2	• Cortocircuito nel cestello superiore.
Il display visualizza E3	• Circuito aperto nel cestello inferiore.
Il display visualizza E4	• Cortocircuito nel cestello inferiore.
Il display visualizza E5	• Errore di comunicazione con la scheda di controllo.
Il display visualizza E6	• Errore di comunicazione con la scheda di alimentazione.

*Se il display mostra codici di errore, l'apparecchio deve essere riparato da un Centro di Assistenza.

Dati tecnici

Prodotto	Air Fryer
Modello	EAFD11B
Voltaggio (V~)	220 V - 240 V
Potenza (W)	2700 W
Frequenza (Hz)	50 - 60 Hz
Watt	4 L + 7 L



Naudojimo žinynas

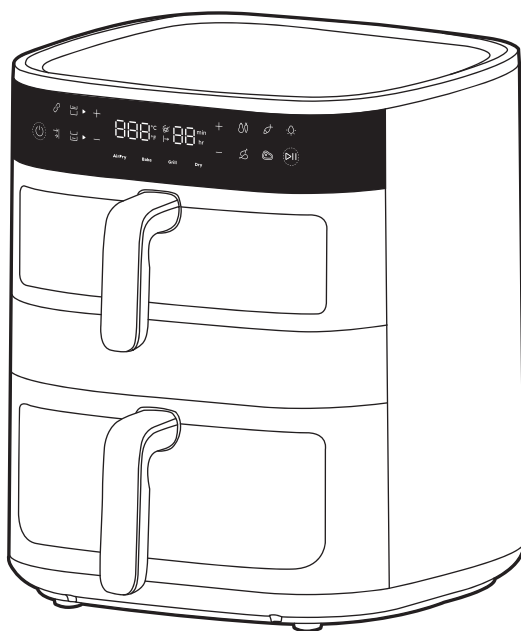

800 karšto oro gruzdintuvė "Dual"

Bendroji apžvalga

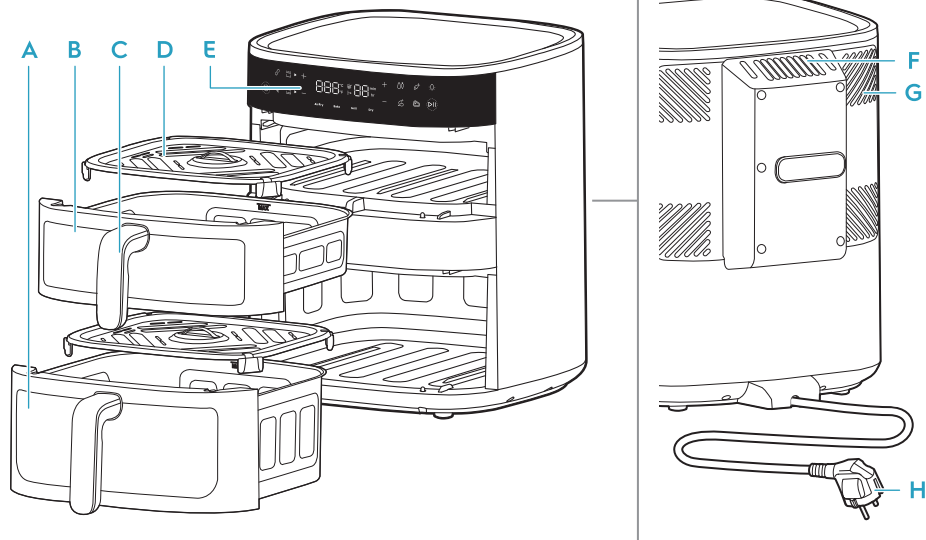

- A** Apatinis krepšelis (7 l) **C** Krepšelio rankena **E** Valdymo skydelis **G** Aušinimo sistema
B Viršutinis krepšelis (4 l) **D** Grotelės **F** Oro išleidimo anga **H** Pagrindinis laidas

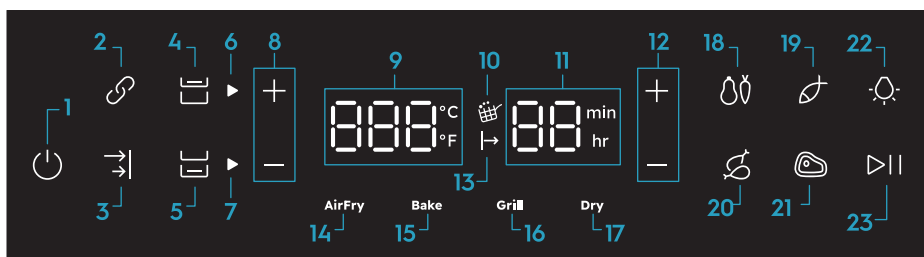

- | | | | |
|---|--|---|-------------------------|
| 1. Įjungimas / išjungimas | 7. Apatinio krepšelio indikatorius | 11. Laiko indikatorius (kepimas karštu oru: 1-99 min., džiovinimas: 1-5 val.) | 16. Grilio funkcija |
| 2. Susiejimo funkcija | 8. Temperatūros valdymas | 12. Laiko valdymas | 17. Džiovinimo funkcija |
| 3. Gaminimo pabaigos sinchronizavimo funkcija | 9. Temperatūros indikatorius (40-200 °C) | 13. Laukiama gaminimo pradžios | 18. Daržovės |
| 4. Viršutinio krepšelio valdymas | 10. Priminimas pakratyti | 14. Kepimo karštu oru funkcija | 19. Žuvis |
| 5. Apatinio krepšelio valdymas | | 15. Kepimo funkcija | 20. Vištiena |
| 6. Viršutinio krepšelio indikatorius | | | 21. Kepsnys |
| | | | 22. Apšvietimo valdymas |
| | | | 23. Paleisti / pauzė |

Prieš pirmą kartą naudojant

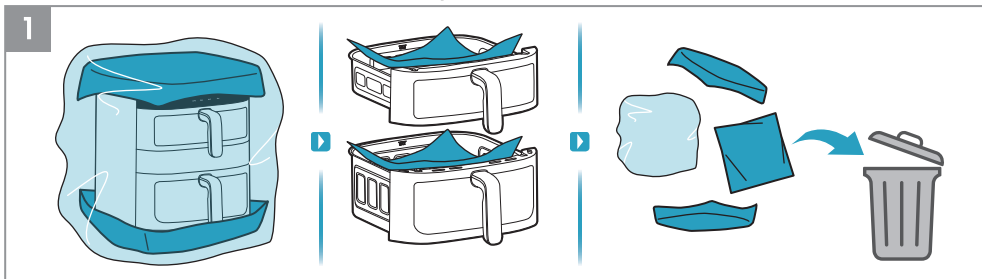

1. Nuimkite visą pakuotę ir apsaugines medžiagas.

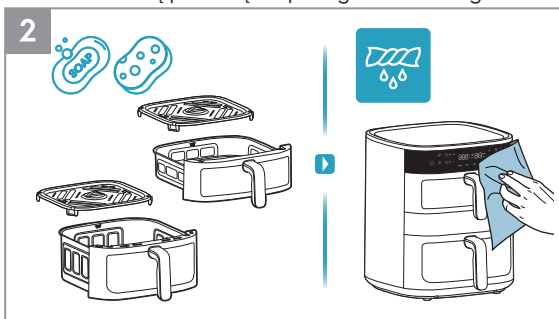

2. Keptuvę ir groteles plaukite šiltu vandeniu ir indų plovikliu. Prietaiso vidų ir išorę valykite minkšta šluoste.

3. Normalu, kad naujas prietaisas pirmuosius kelis kartus jį naudojant gali skleisti kvapą. Siekiant to išvengti, prieš pirmąjį naudojimą 20 minučių įkaitinkite tuščią karšto oro gruzdintuvę iki 200 °C.

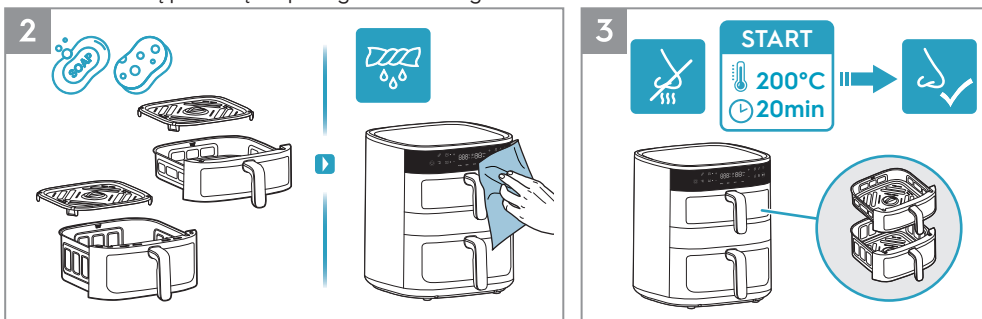

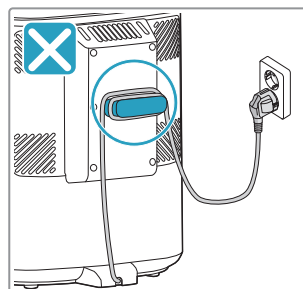
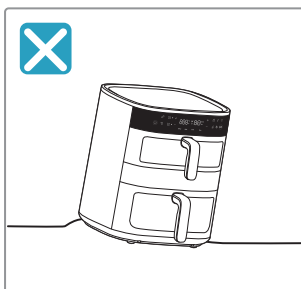
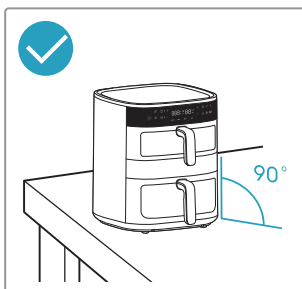
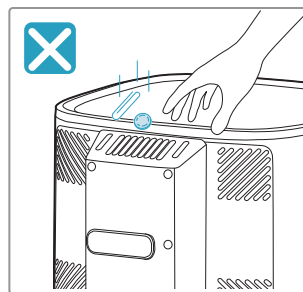
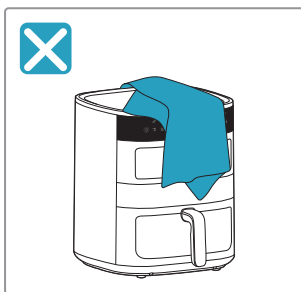
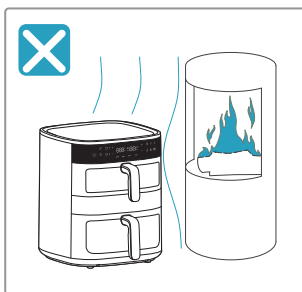

! Saugos priemonės





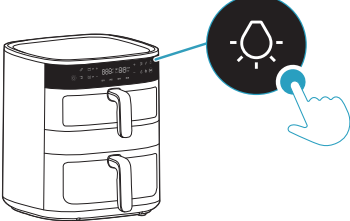
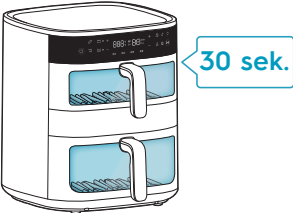











EN
BG
CZ
DE
DK
EE
FI
FR
HR
GR
HU
IT
LT
LV
NO
NL
PL
PT
RO
RU
SE
SI
SK
SR
TR
UA
ES
GE
AL







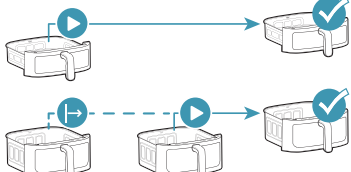







Apšvietimo valdymas ir temperatūros skalės konvertavimas

 <p>Apšvietimo valdymas</p>		 <p>30 sek.</p>
<p>°C/°F</p> <p>Temperatūros skalės konvertavimas</p>	 <p>30 sek.</p>	

Krepšelio pasirinkimas

	 <p>4l</p>	 <p>7l</p>	
 <p>Viršutinis krepšelis</p>			
 <p>Apatinis krepšelis</p>			
 <p>Susiejimo funkcija</p>			
 <p>Gaminimo pabaigos sinchronizavimo funkcija</p>			

Iš anksto nustatytos funkcijos

					
Air Fry	180°C	15min.	60-200°C	1-99min.	
	170°C	10min.	60-200°C	1-99min.	
	140°C	15min.	60-200°C	1-99min.	
	180°C	30min.	60-200°C	1-99min.	
	200°C	10min.	60-200°C	1-99min.	
Bake	170°C	15min.	60-200°C	1-99min.	
Grill	200°C	5min.	60-200°C	1-99min.	
Dry	80°C	5val.	40-80°C	1-5val.	

Prieš gaminant

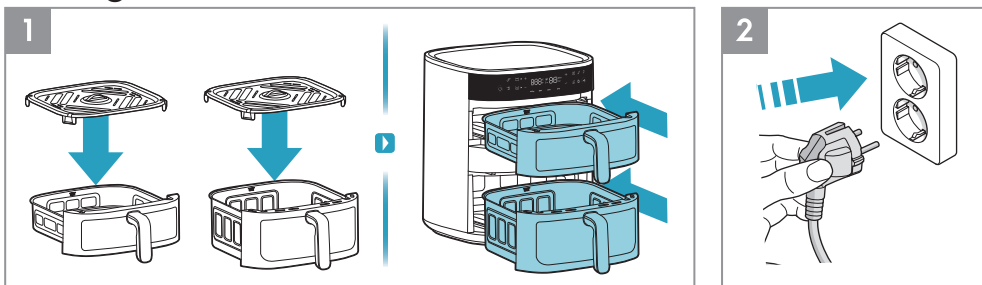

1. Kiekvieną kartą prieš gamindami, įdėkite grotelės į krepšelį (karščiui atsparaus silikoninio grotelių padėklo nuimti nereikia) ir iki galo įstumkite krepšelį į prietaisą.
2. Įkiškite maitinimo kištuką į elektros lizdą.

EN
BG
CZ
DE
DK
EE
FI
FR
HR
GR
HU
IT
LT
LV
NO
NL
PL
PT
RO
RU
SE
SI
SK
SR
TR
UA
ES
GE
AL

Naudojimas - vienas krepšelis

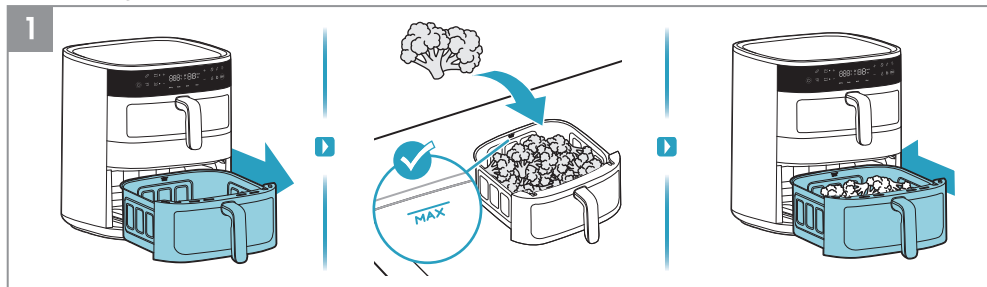

1. Ištraukite vieną krepšelį ir pastatykite jį ant stabilaus paviršiaus, sudėkite į jį maisto produktus, atsižvelgdami į "MAX" talpos žymę. Tada įstumkite krepšelį su maisto produktais atgal į prietaisą.

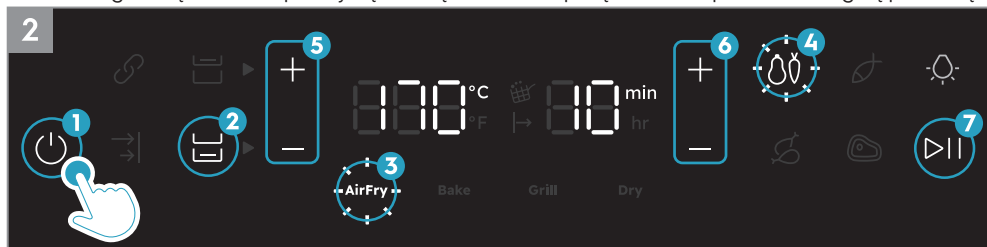

2. Paspauskite įjungimo / išjungimo mygtuką. Pirmiausia pasirinkite krepšelį su patiekalu. Tada pasirinkite norimą gaminimo būdą, pavyzdžiui, kepimo karštu oru funkciją. Nustatykite laiką ir temperatūrą pagal savo skonį arba pasirinkite vieną iš iš anksto nustatytų receptų, pavyzdžiui, "Daržovės". Galiausiai paspauskite mygtuką "Paleisti / pauzė".

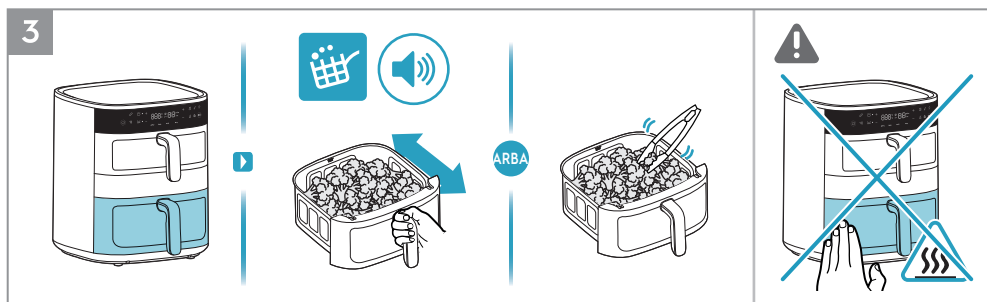

3. Kai gaminimo metu įsižiebia piktograma "Priminimas pakratyti" ir pasigirsta signalas, naudodami karščiu atsparius įrankius vieną kartą apverskite patiekalą arba atsargiai pakratykite patiekalą karšto oro gruzdintuvės krepšelyje.

⚠ **ATSARGIAI!** gruzdintuvės krepšelio per stipriai nekratykite, kad patiekalas neaptaškytų ir nenudegintų.

⚠ **ATSARGIAI!** Kai prietaisas veikia, būkite atsargūs su karštais paviršiais.

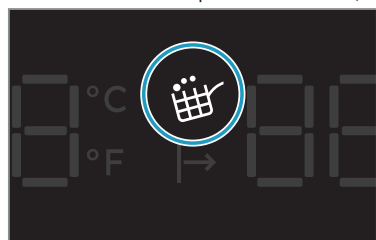

Priminimas pakratyti

"Priminimas pakratyti" įjungiamas naudojant kepimo karštu oru funkciją ir iš anksto nustatytus receptus, pvz., daržovių, žuvies, vištienos šlaunelių ir kepsnių.

Kai ateis laikas pakratyti arba apversti patiekalą, užsidsės ir vieną minutę mirksės piktograma "Priminimas pakratyti", o tris kartus pasigirs pytelėjimas.

"Priminimas pakratyti" nėra privalomas, todėl gaminimas bus tęsiamas įprastai, net jei patiekalas nebus apverstas ar pakratytas.

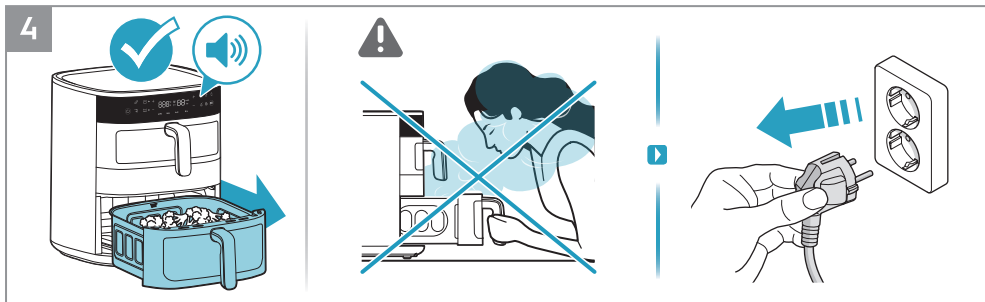

4. Pasibaigus gaminimo laikui, prietaisas praneš apie tai garsiniu signalu. Atsargiai išimkite krepšelį ir padėkite jį ant karščiui atsparaus paviršiaus. Po naudojimo išjunkite prietaisą iš elektros tinklo.

⚠ **ATSARGIAI!** atidarius krepšelį gaminimo metu arba pabaigoje, iš jo gali išsiveržti karšti garai. Atidarydami krepšelį, saugokite veidą, rankas ir plaštakas nuo garų.

Naudojimas - viršutinis + apatinis krepšelis

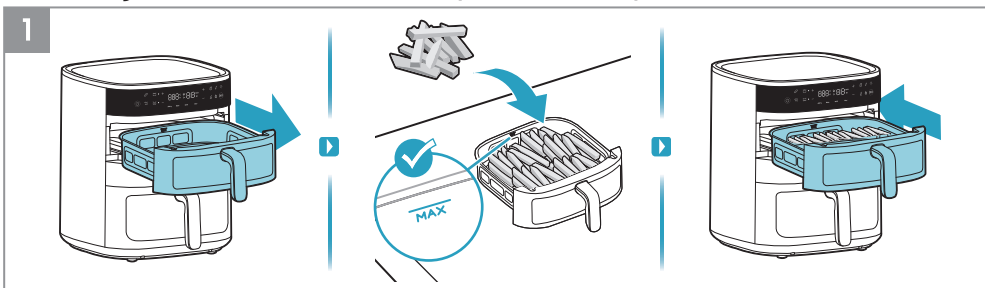

1. Pirmiausia ištraukite viršutinį krepšelį ir sudėkite į jį maisto produktus, pavyzdžiui, bulvytes.

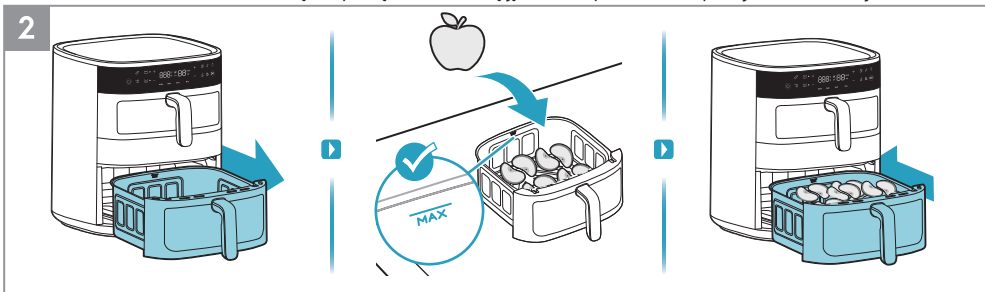

2. Po to ištraukite apatinį krepšelį ir sudėkite į jį maisto produktus, pavyzdžiui, obuolių griežinėlius.



3. Paspauskite įjungimo / išjungimo mygtuką. Pirmiausia pasirinkite viršutinį krepšelį. Tada pasirinkite norimą gaminimo būdą, pavyzdžiui, kepimo karštu oru funkciją. Nustatykite laiką ir temperatūrą pagal savo skonį arba pasirinkite vieną iš anksto nustatytų receptų, pavyzdžiui, "Daržovės". Galiausiai paspauskite mygtuką "Paleisti / pauzė".



4. Po to pasirinkite apatinį krepšelį. Tada pasirinkite norimą gaminimo būdą, pavyzdžiui, džiovinimo funkciją. Nustatykite laiką ir temperatūrą pagal savo pageidavimus. Galiausiai paspauskite mygtuką "Paleisti / pauzė".

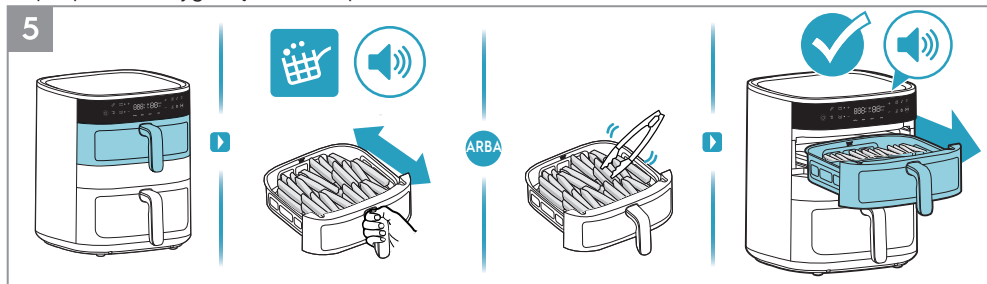

5. Kai gaminimo metu įsižiebia piktograma "Priminimas pakratyti" ir pasigirsta signalas, naudodami karščiui atsparius įrankius vieną kartą apverskite patiekalą arba atsargiai pakratykite patiekalą karšto oro gruzdintuvės krepšelyje. Pasibaigus viršutinio krepšelio gaminimo laikui, prietaisas praneš apie tai garsiniu signalu.

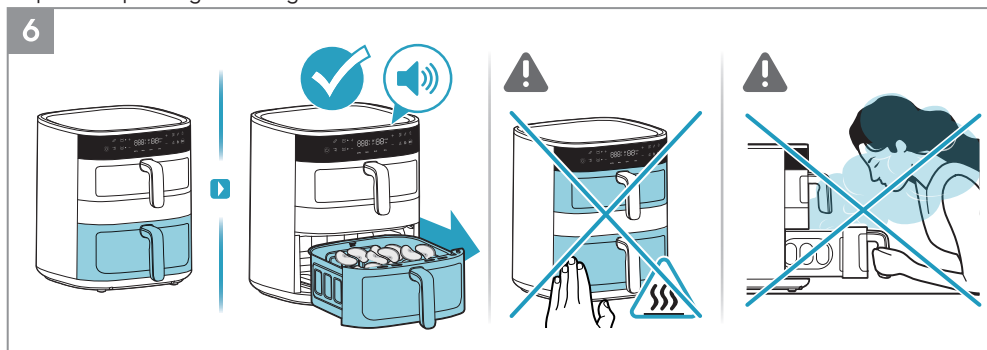

6. Pasibaigus apatinio krepšelio gaminimo laikui, prietaisas praneš apie tai garsiniu signalu.

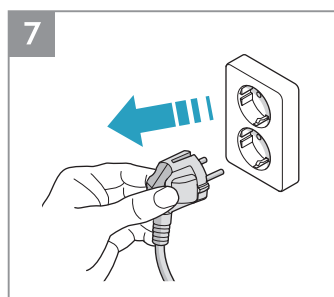

7. Po naudojimo išjunkite prietaisą iš elektros tinklo.

Naudojimas - susiejimo funkcija

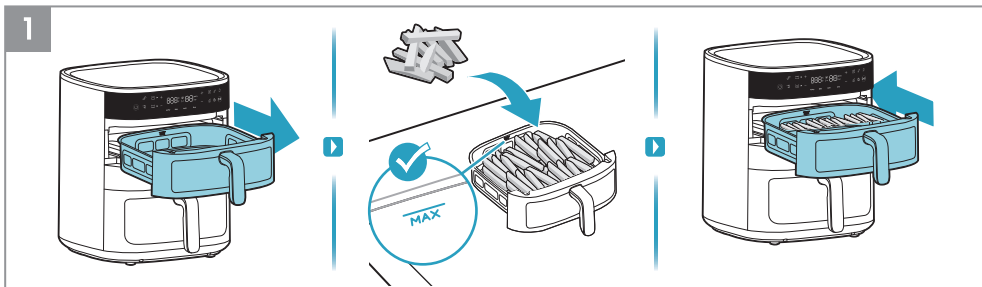

1. Pirmiausia ištraukite viršutinį krepšelį ir sudėkite į jį maisto produktus, pavyzdžiui, bulvytes.

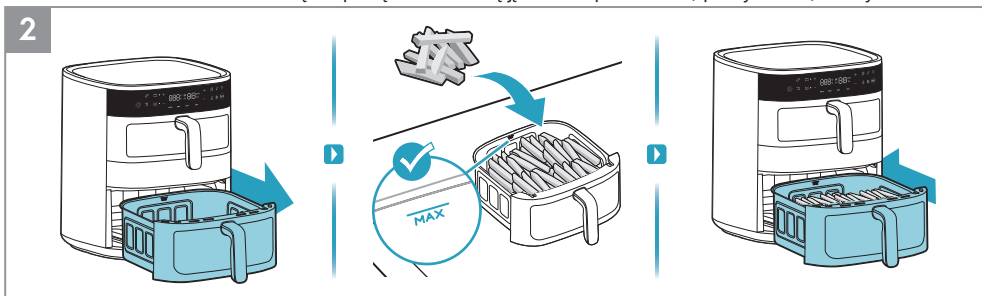

2. Po to ištraukite apatinį krepšelį ir sudėkite į jį maisto produktus, pavyzdžiui, bulvytes.



3. Paspauskite įjungimo / išjungimo mygtuką. Pirmiausia pasirinkite susiejimo funkciją. Tada pasirinkite norimą gaminimo būdą, pavyzdžiui, kepimo karštu oru funkciją. Nustatykite laiką ir temperatūrą pagal savo skonį arba pasirinkite vieną iš anksto nustatytų receptų. Galiausiai paspauskite mygtuką "Paleisti / pauzė".

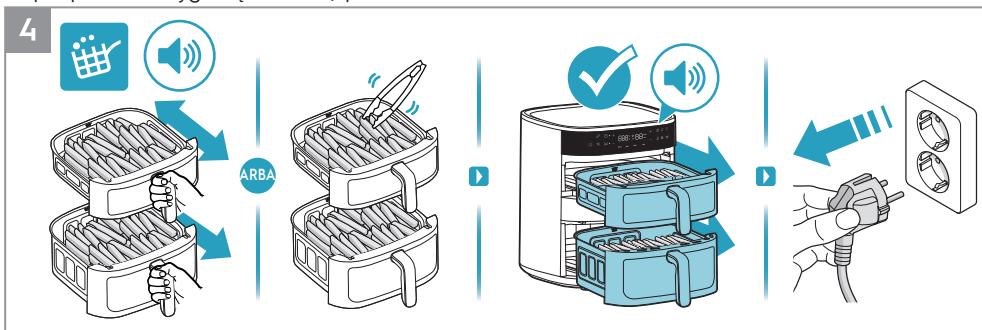

4. Kai gaminimo metu įsijiebia piktograma "Priminimas pakratyti" ir pasigirsta signalas, naudodami karščiui atsparius įrankius vieną kartą apverskite patiekalą arba atsargiai pakratykite patiekalą karšto oro gruzdintuvės krepšelyje. Pasibaigus gaminimo laikui, prietaisas praneš apie tai garsiniu signalu. Po naudojimo išjunkite prietaisą iš elektros tinklo.

Naudojimas - gaminimo pabaigos sinchronizavimo funkcija

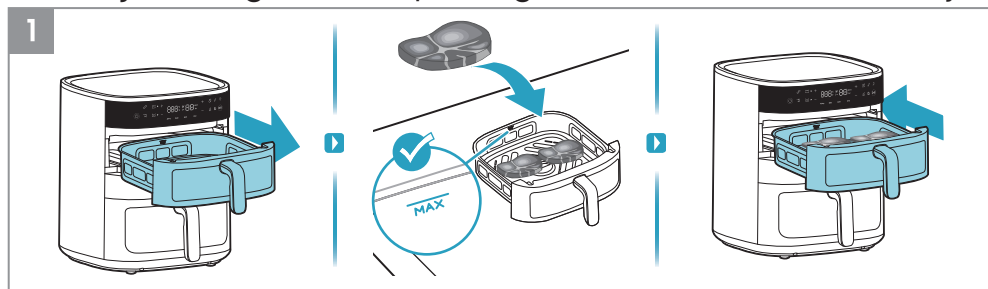

1. Pirmiausia ištraukite viršutinį krepšelį ir sudėkite į jį maisto produktus, pavyzdžiui, kepsnį.

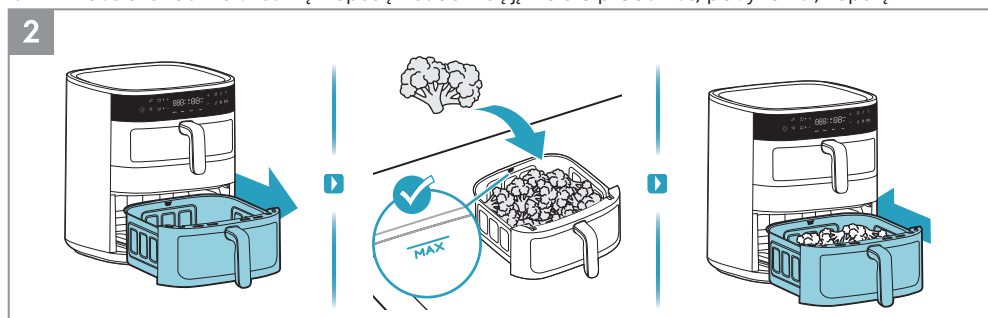

2. Po to ištraukite apatinį krepšelį ir sudėkite į jį maisto produktus, pavyzdžiui, brokolius.



3. Paspauskite įjungimo / išjungimo mygtuką. Pasirinkite "Gaminimo pabaigos sinchronizavimo funkcija". Pirmiausia pasirinkite viršutinį krepšelį, tada pasirinkite norimą gaminimo būdą, pavyzdžiui, kepimo karštu oru funkciją. Nustatykite laiką ir temperatūrą pagal savo skonį arba pasirinkite vieną iš anksto nustatytų receptų, pavyzdžiui, "Kepsnys".

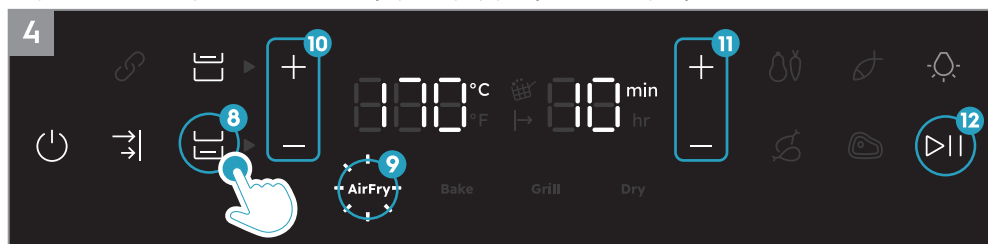

4. Tada pasirinkite apatinį krepšelį ir norimą gaminimo būdą, pavyzdžiui, kepimo karštu oru funkciją. Nustatykite laiką ir temperatūrą pagal savo skonį arba pasirinkite vieną iš anksto nustatytų receptų. Galiausiai paspauskite mygtuką "Paleisti / pauzė".

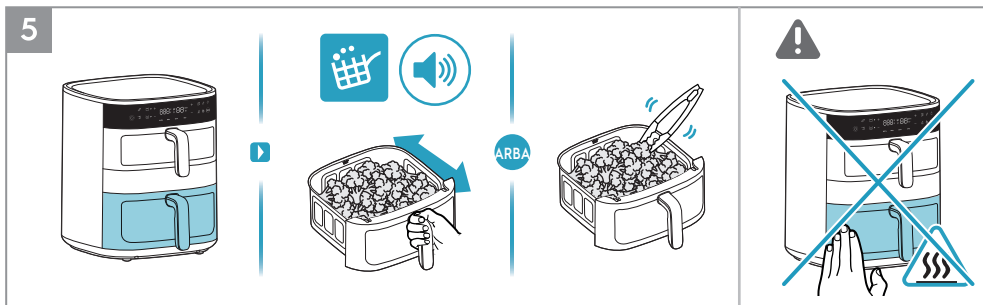

5. Gaminant pirmenybė bus teikiama apatiniam krepšeliui, kuriam nustatytas ilgesnis gaminimo laikas. Kai gaminimo metu įsižiebia piktograma "Priminimas pakratyti" ir pasigirsta signalas, naudodami karščiui atsparius įrankius vieną kartą apverskite patiekalą arba atsargiai pakratykite patiekalą karšto oro gruzdintuvės krepšelyje.

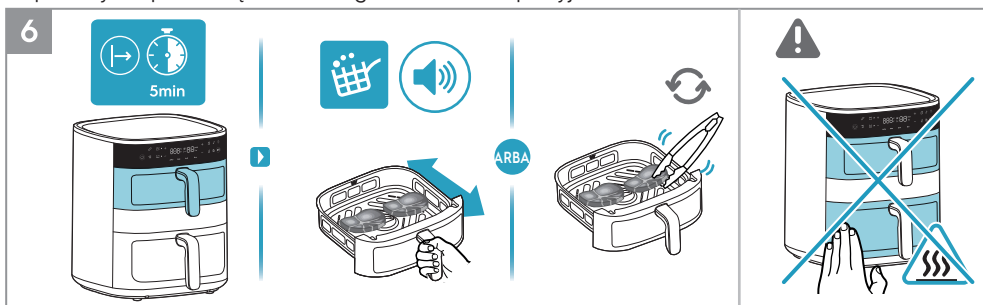

6. Po to pradės kepti viršutinis krepšelis su trumpesniu kepimo laiku. Kai gaminimo metu įsižiebia piktograma "Priminimas pakratyti" ir pasigirsta signalas, naudodami karščiui atsparius įrankius vieną kartą apverskite patiekalą arba atsargiai pakratykite patiekalą karšto oro gruzdintuvės krepšelyje.

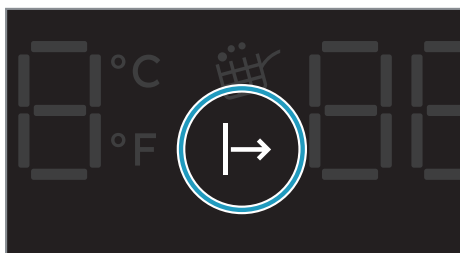

Indikatorius "Laukiama gaminimo pradžios"

Kai suaktyvinta "Gaminimo pabaigos sinchronizavimo funkcija", krepšelis su trumpesniu gaminimo laiku turės šiek tiek palaukti, kol bus gaminamas patiekalas krepšelyje su ilgesniu gaminimo laiku, kad abu krepšeliai galėtų baigti gaminimą vienu metu. Per šį laiką, kol prasidės gaminimas, bus įjungtas indikatorius "Laukiama gaminimo pradžios".

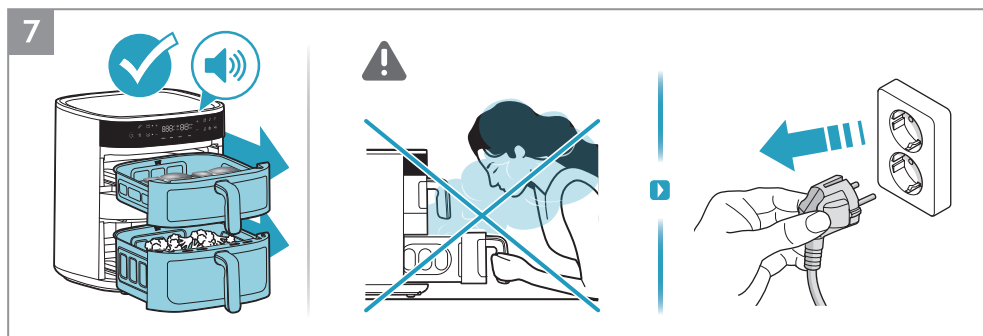

7. Pasibaigus gaminimo laikui, prietaisas praneš apie tai garsiniu signalu. Po naudojimo išjunkite prietaisą iš elektros tinklo.

Valymas

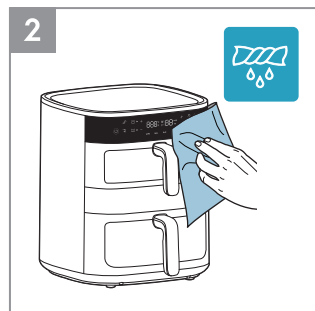
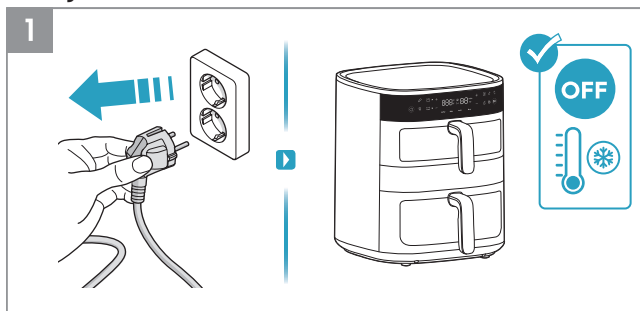

1. Prieš valydami visada atjunkite prietaisą nuo elektros tinklo ir palaukite, kol jis atvės.
2. Prietaiso išorę valykite minkšta šluoste.

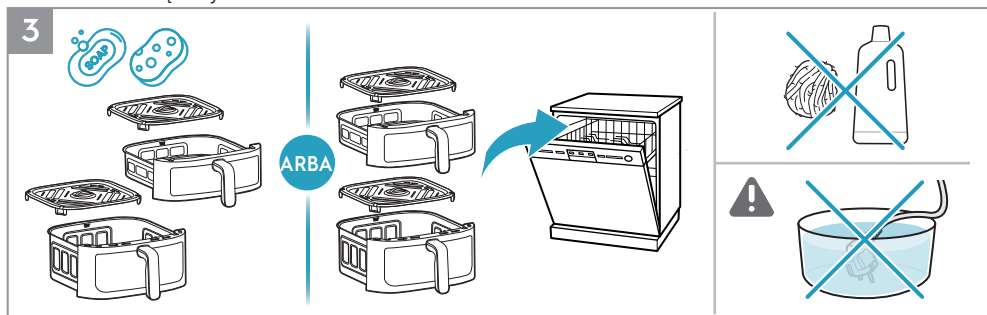

3. Keptuvą ir groteles nuplaukite šiltu vandeniu ir indų plovikliu arba įdėkite į indaplovę.

▲PASTABA: kad apsugotumėte nepridegančią dangą, venkite naudoti abrazyvines valymo priemones ar metalinius įrankius.



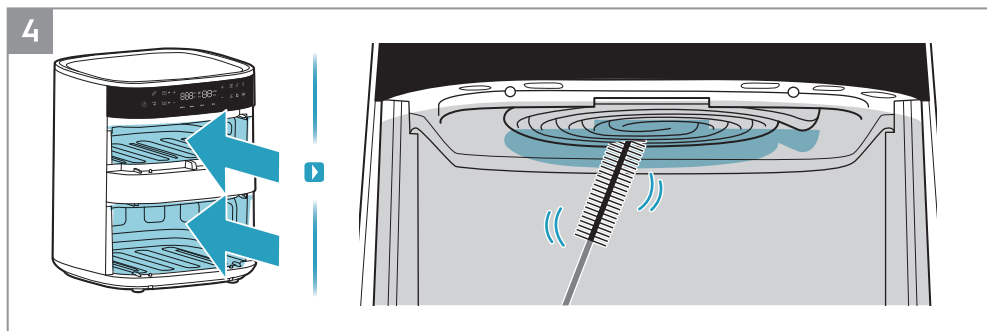









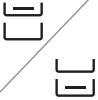

























ATSARGIAI! Niekada nenardinkite gaminio, jo laido ar kištuko į vandenį ar kitą skystį.



4. Kaitinimo elementą valykite valymo šepečiu.













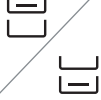













PASTABA: Prieš valydami kaitinimo elementą, įsitinkinkite, kad prietaisas visiškai atvėso.

Gaminimo žinynas

							
AirFry	7mm/10mm 	 4l	400g	180°C	18min.		
		 7l	400g	180°C	18min.		
AirFry		 4l	400g	170°C	8min.		
		 7l	400g	170°C	10min.		
AirFry		 4l	400g/2vnt	140°C	15min.		
		 7l	400g/2vnt	140°C	15min.		
AirFry		 4l	1000g/8vnt.	180°C	28min.		
		 7l	1000g/8vnt.	180°C	28min.		
AirFry		 4l	400g/2vnt	200°C	10min.		
		 7l	400g/2vnt	200°C	10min.		
AirFry		 4l	220g/6inches	160°C	12min.		
		 7l	220g/6inches	160°C	14min.		

- EN
- BG
- CZ
- DE
- DK
- EE
- FI
- FR
- GR
- HR
- HU
- IT
- LT**
- LV
- NO
- NL
- PL
- PT
- RO
- RU
- SE
- SI
- SK
- SR
- TR
- UA
- ES
- GE
- AL

EN
BG
CZ
DE
DK
EE
FI
FR
HR
GR
HU
IT
LT
LV
NO
NL
PL
PT
RO
RU
SE
SI
SK
SR
TR
UA
ES
GE
AL

							
AirFry		7l 	1200g	180°C	55min.		
AirFry		7l 	400g/9vnt	160°C	20min.		
Grill		4l 	180g/4vnt	180°C	8min.		
Grill		7l 	180g/4vnt	180°C	9min..		
Dry		4l 	180g	80°C	3val.		
Dry		7l 	180g	80°C	3val.		
Dry		4l 	200g	80°C	3val.		
Dry		7l 	200g	80°C	3val.		

KAŲ DARYTI JEI...

Problema	Patikrinkite...
Negalite įjungti arba valdyti prietaiso.	<ul style="list-style-type: none"> • Ar prietaisas tinkamai prijungtas prie elektros tinklo. • Ar krepšeliai yra teisingoje padėtyje. Įsitinkinkite, kad jie iki galo įstumti į prietaisą, kad būtų įjungtas elektros tiekimas. • Ar nustatytas gaminių laikas.
Negalite įstumti krepšelio į prietaisą.	<ul style="list-style-type: none"> • Ar krepšelis nepripildytas virš didžiausios talpos. • Ar krepšelis įdėtas teisingai. Įdėjus jį į prietaisą, jis turi spragtelėti. • Ar po krepšeliu nėra daikto, trukdančio jį tinkamai uždaryti.
Iš prietaiso veržiasi balti dūmai.	<ul style="list-style-type: none"> • Ar jūsų ruošiamas patiekalas nėra per riebus. • Ar krepšelis, grotelės ir kaitinimo elementas yra švarūs.
Ekrane rodoma E1	• Viršutinio krepšelio atvira grandinė.
Ekrane rodoma E2	• Viršutinio krepšelio trumpasis jungimas.
Ekrane rodoma E3	• Apatinio krepšelio atvira grandinė.
Ekrane rodoma E4	• Apatinio krepšelio trumpasis jungimas.
Ekrane rodoma E5	• Valdymo PCBA ryšio triktis.
Ekrane rodoma E6	• Maitinimo PCBA ryšio triktis.

* Jei ekrane rodomi klaidų kodai, prietaisą turi remontuoti techninės priežiūros centras.

Techniniai duomenys

Produktas	Karšto oro gruzdintuvė
Modelis	EAFD11B
Įtampa (V~)	220 V - 240 V
Galia (W)	2700 W
Dažnis (Hz)	50 ~ 60 Hz
Talpa	4 l + 7 l



Instrukcija

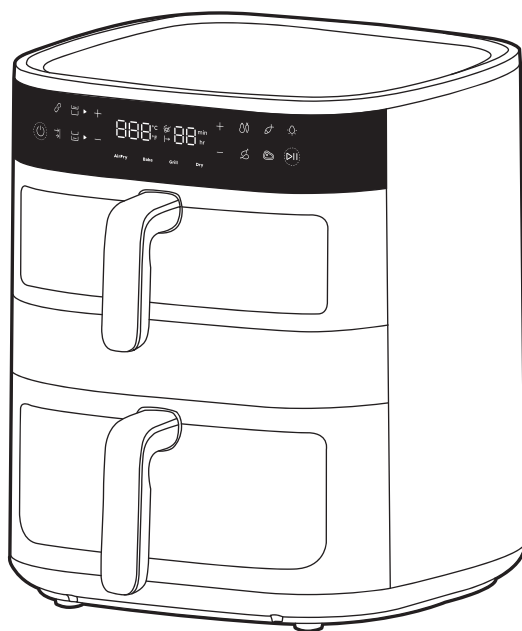

800 Duālais gaisa fritēris

Vispārīgs pārskats

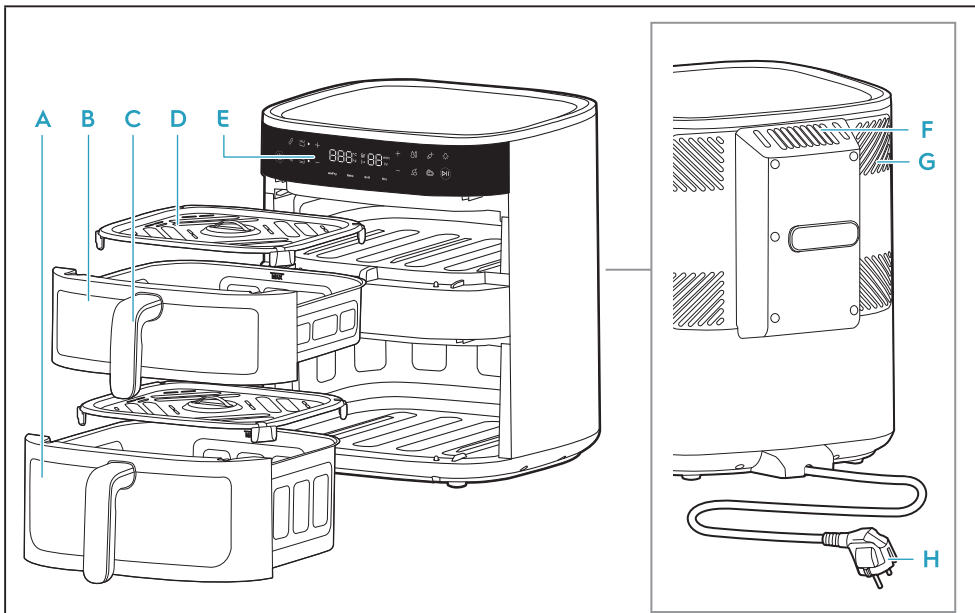

- A** Apakšējais grozs (7 l) **C** Groza rokturis **E** Vadības panelis **G** Dzesēšanas sistēma
B Augšējais grozs (4 l) **D** Režģis **F** Gaisa izplūde **H** Galvenais vads

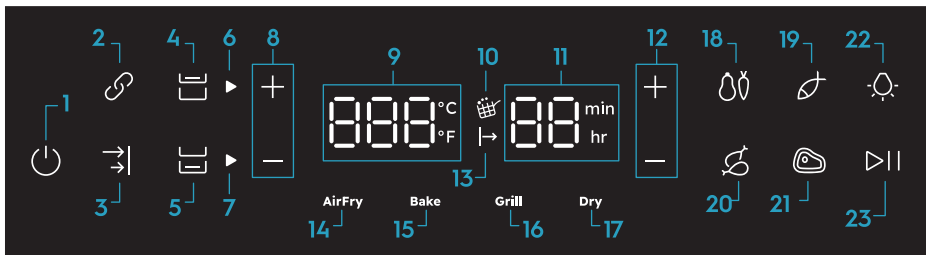

- | | | | |
|-----------------------------------|--|-------------------------------|--------------------|
| 1. Ieslēgt/Izslēgt | 9. Temperatūras indikators(40-200 °C) | 14. Gaisa fritēšanas funkcija | 21. Steiks |
| 2. Saites funkcija | 10. Sakratīšanas atgādinājums | 15. Cepšanas funkcija | 22. Gaismas vadība |
| 3. Sinhronas pabeigšanas funkcija | 11. Laika indikators (Gaisa fritēšana: 1-99 min, Žāvēšana: 1-5h) | 16. Grila funkcija | 23. Palaist/Pauze |
| 4. Augšējā groza vadība | 12. Laika vadība | 17. Žāvēšanas funkcija | |
| 5. Apakšējā groza vadība | 13. Laiks līdz gatavošanai | 18. Dārzeni | |
| 6. Augšējā groza indikators | | 19. Zivs | |
| 7. Apakšējā groza indikators | | 20. Vista | |
| 8. Temperatūras vadība | | | |

Pirms pirmās lietošanas

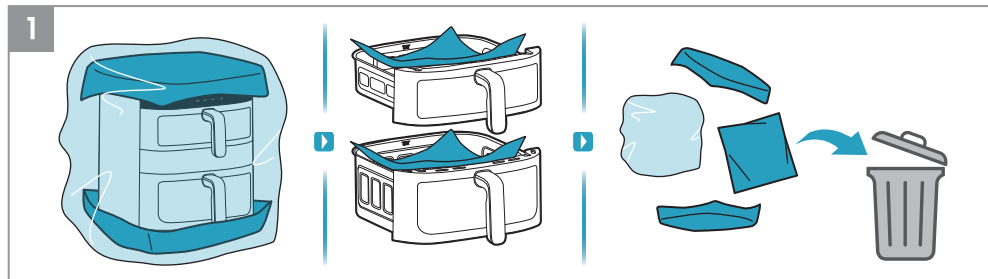

1. Noņemiet visu iepakojuma un aizsardzības materiālu.

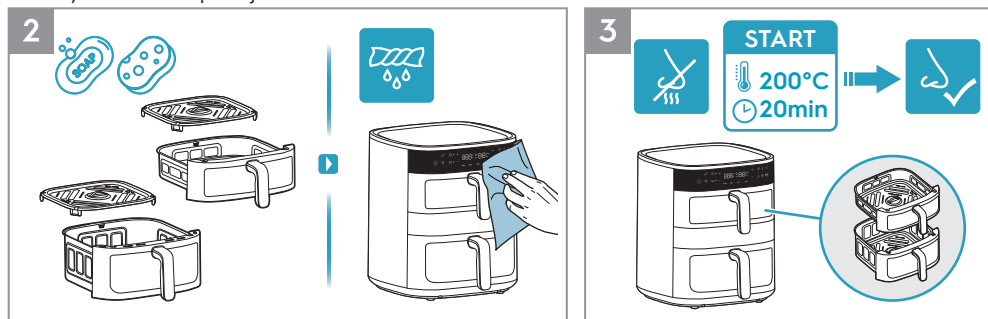



2. Notīriet pannu un režģi ar siltu ūdeni un trauku mazgāšanas līdzekli. Noslaukiet ierīces iekšpusi un ārpusi ar mīkstu drānu.

3. Pirmajās darbošanās reizēs ir normāli, ka jauna ierīce izdala smakas. Lai no tā izvairītos, pirms pirmās lietošanas darbiniet gaisa fritēri tukšu 20 minūtes 200 °C temperatūrā.

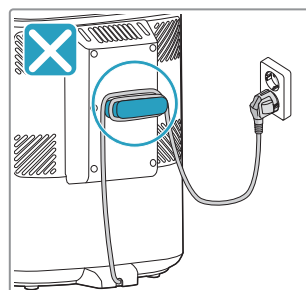
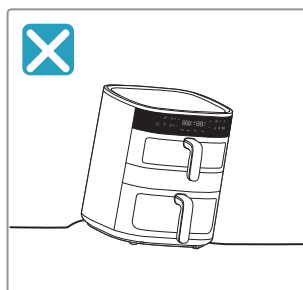
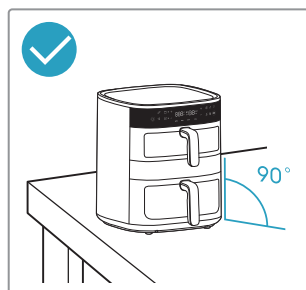
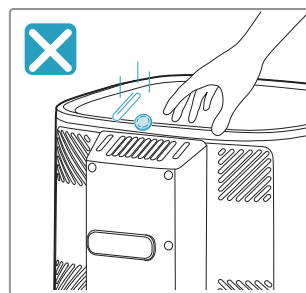
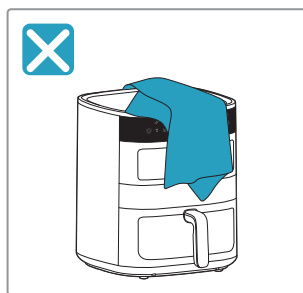
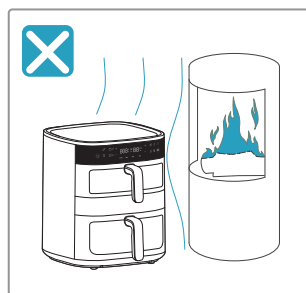



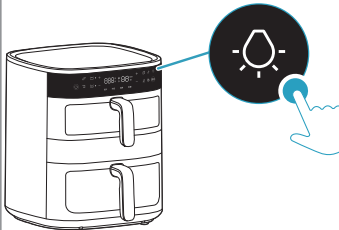
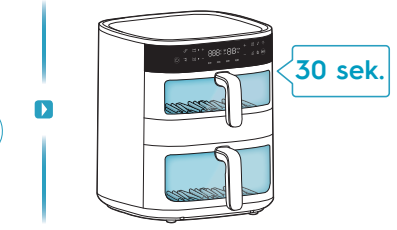

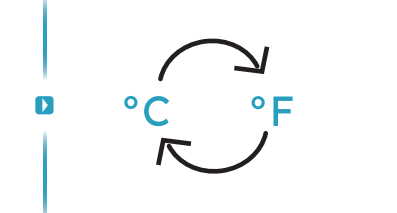





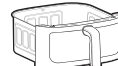

! Piesardzības pasākumi









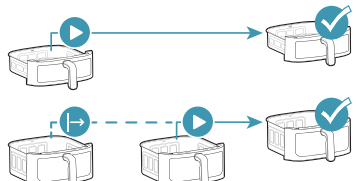



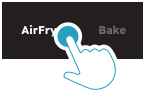



Apgaismojuma vadība un temperatūras skalas pārveidošana

 <p>Apgaismojuma vadība</p>		
<p>°C/°F</p> <p>Temperatūras skalas pārveidošana</p>		

Groza izvēle

	 <p>4L</p>	 <p>7L</p>	
 <p>Augšējais grozs</p>			
 <p>Apakšējais grozs</p>			
 <p>Saites funkcija</p>			
 <p>Sinhronas pabeigšanas funkcija</p>			

Iepriekš iestatītas funkcijas

					
AirFry	180°C	15min	60-200°C	1-99min	
	170°C	10min	60-200°C	1-99min	
	140°C	15min	60-200°C	1-99min	
	180°C	30min	60-200°C	1-99min	
	200°C	10min	60-200°C	1-99min	
Bake	170°C	15min	60-200°C	1-99min	
Grill	200°C	5min	60-200°C	1-99min	
Dry	80°C	5h	40-80°C	1-5h	

Pirms gatavošanas

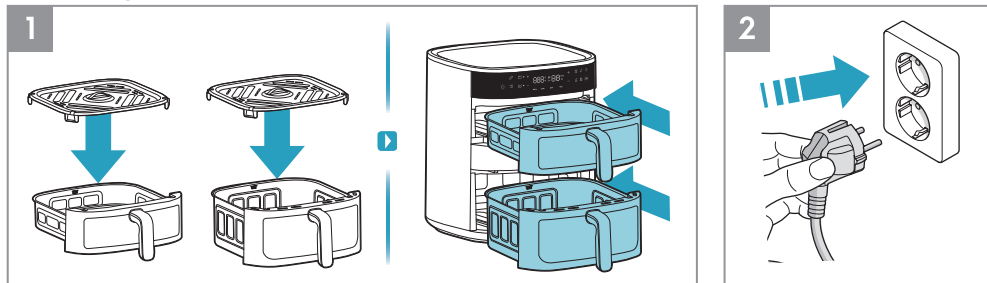

1. Pirms katras gatavošanas, lūdzu, ievietojiet režģi grozā (karstumizturīgo silikona apakšējo režģa paliktni nav jāņem nost) un iestumiet grozu ierīcē līdz galam.
2. Ievietojiet strāvas kontaktdakšu elektrības kontaktligzdā.

Lietošana – Viens grozs

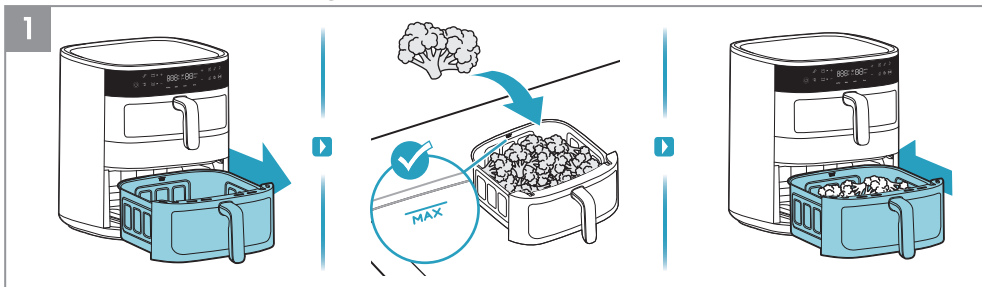

1. Izvelciet grozu ārā un novietojiet to uz stabilas virsmas, ievietojiet pārtiku grozā, ievērojot ietilpības norādi "MAX.". Tad iestumiet grozu ar pārtiku atpakaļ ierīcē līdz galam.

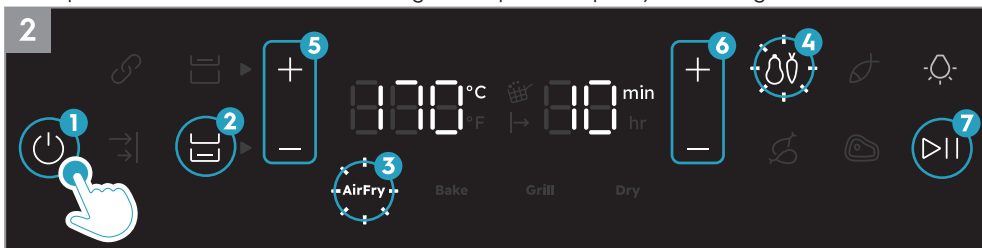

2. Nospiediet Ieslēgšanas/Izslēgšanas pogu. Vispirms atlasiet grozu, kurā ir pārtika. Tad atlasiet vēlamo gatavošanas metodi, piemēram, gaisa fritēšanas funkciju. Noregulējiet laiku un temperatūru pēc vajadzības vai atlasiet kādu no iepriekš iestatītajām receptēm, piemēram, Dārzeni. Visbeidzot nospiediet pogu Palaist/Pauze.

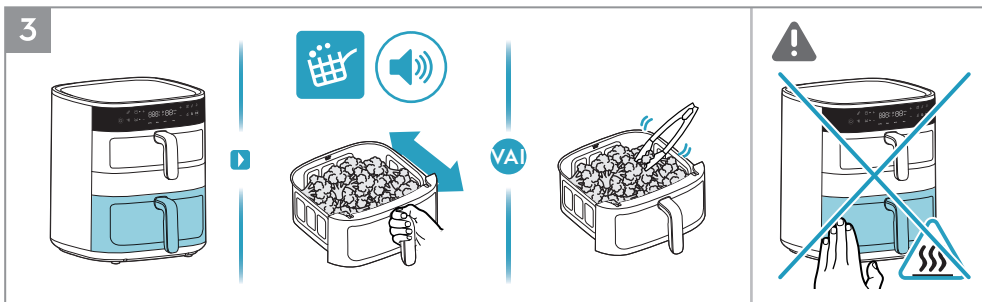

3. Kad gatavošanas procesa laikā iedegas "Sakratīšanas atgādinājuma" ikona un atskan pikstiens, ar karstumizturīgu rīku palīdzību apgrieziet pārtiku otrādi vai nedaudz viegli sakratiet fritēšanas grozā esošo pārtiku.

⚠ **UZMANĪBU:** Nekratiet fritēšanas grozu pārāk enerģiski, lai izvairītos no pārtikas šļakstēšanas un apdegumu radīšanas.

⚠ **UZMANĪBU:** Ierīces lietošanas laikā rīkojieties uzmanīgi ar karstām virsmām.

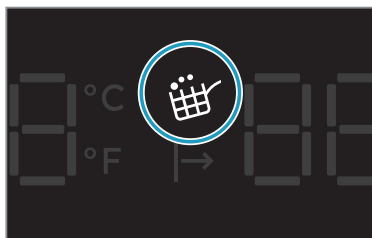

Sakratīšanas atgādinājums

"Sakratīšanas atgādinājums" tiek aktivizēts gaisa fritēšanas funkcijas un iepriekš iestatīto recepšu, piemēram, dārzeni, zivs, vistas kāju un steika darbības laikā.

Kad pienācis laiks pārtiku sakratīt vai pagriezt otrādi, iedegsies un vienu minūti mirgos "Sakratīšanas atgādinājuma" ikona, kā arī trīs reizes atskanēs pikstienu signāls.

"Sakratīšanas atgādinājums" nav obligāts, jo gatavošana turpināsies kā parasti arī tad, ja pārtika netiek pagriezt otrādi vai sakratīta.

EN
BG
CZ
DE
DK
EE
FI
FR
GR
HR
HU
IT
LT
LV
NO
NL
PL
PT
RO
RU
SE
SI
SK
SR
TR
UA
ES
GE
AL

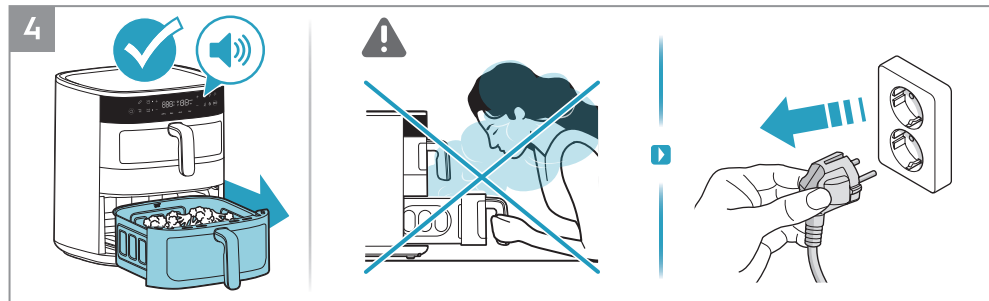

4. Beidzoties gatavošanas laikam, ierīce dos pīkstiena skaņas signālu. Uzmanīgi izņemiet grozu un novietojiet to uz karstumizturīgas virsmas. Pēc lietošanas atvienojiet ierīci no elektrotīkla.

⚠ **UZMANĪBU:** Ja grozs tiek izņemts gatavošanas vidū vai beigās, no tā var nākt karsts gaiss. Atverot, noteikti sargiet seju, rokas un plaukstas no tvaika.

Lietošana - Augšējais + Apakšējais grozs

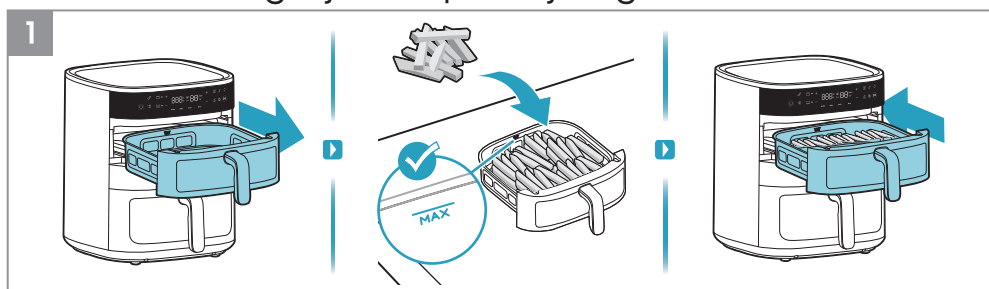

1. Vispirms izvelciet ārā augšējo grozu un ievietojiet tajā pārtiku, piemēram, fri kartupeļus.

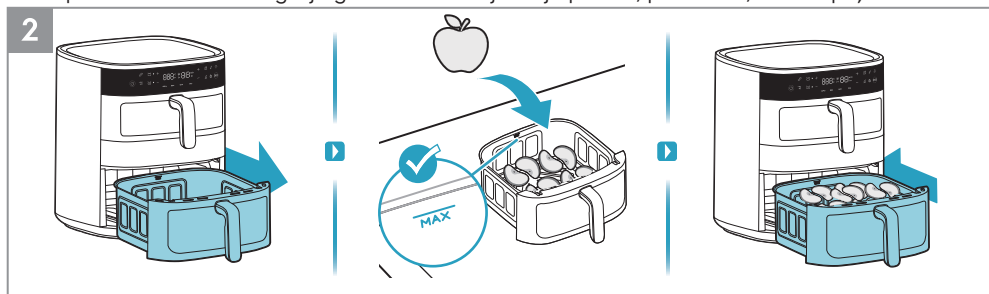

2. Pēc tam izvelciet ārā apakšējo grozu un ievietojiet tajā pārtiku, piemēram, ābola šķēles.



3. Nospiediet ieslēgšanas/Izslēgšanas pogu. Vispirms atlasiet augšējo grozu. Tad atlasiet vēlamo gatavošanas metodi, piemēram, gaisa fritēšanas funkciju. Noregulējiet laiku un temperatūru pēc vajadzības vai atlasiet kādu no iepriekš iestatītajām receptēm, piemēram, Dārzeni. Visbeidzot nospiediet pogu Palaist/Pauze.



4. Pēc tam atlasiet apakšējo grozu. Tad atlasiet vēlamo gatavošanas metodi, piemēram, Žāvēšanas funkciju. Noregulējiet laiku un temperatūru pēc vajadzības. Visbeidzot nospiediet pogu Palaist/Pauze.

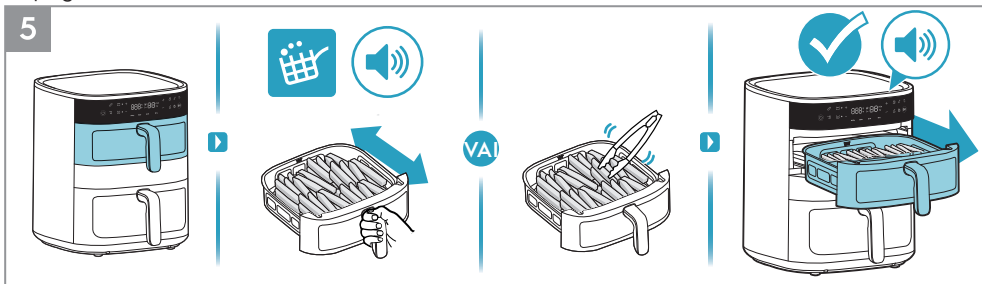

5. Kad gatavošanas procesa laikā iedegas "Sakratīšanas atgādinājuma" ikona un atskan pikstiens, ar karstumizturīgu rīku palīdzību apgrieziet pārtiku otrādi vai nedaudz viegli sakratiet fritēšanas grozā esošo pārtiku. Augšējā groza gatavošanas laika beigās ierīce dos pikstienu skaņas signālu.

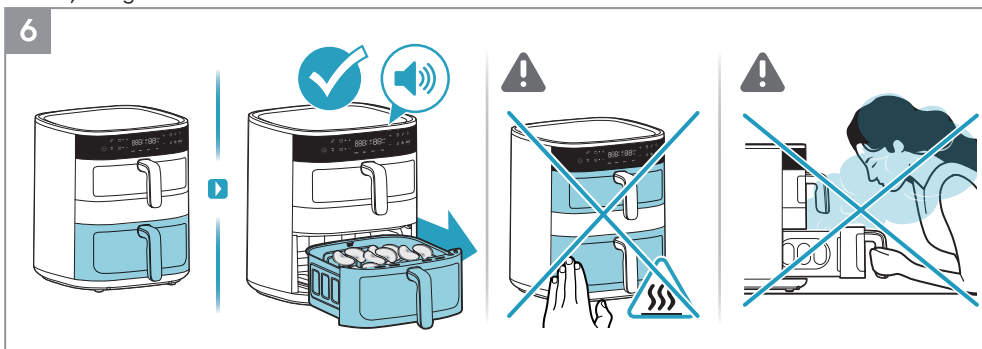

6. Apakšējā groza gatavošanas laika beigās ierīce dos pikstienu skaņas signālu.

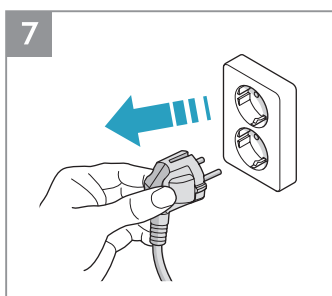

7. Pēc lietošanas atvienojiet ierīci no elektrotīkla.

EN
BG
CZ
DE
DK
EE
FI
FR
GR
HR
HU
IT
LT
LV
NO
NL
PL
PT
RO
RU
SE
SI
SK
SR
TR
UA
ES
GE
AL

Lietošana - Saites funkcija

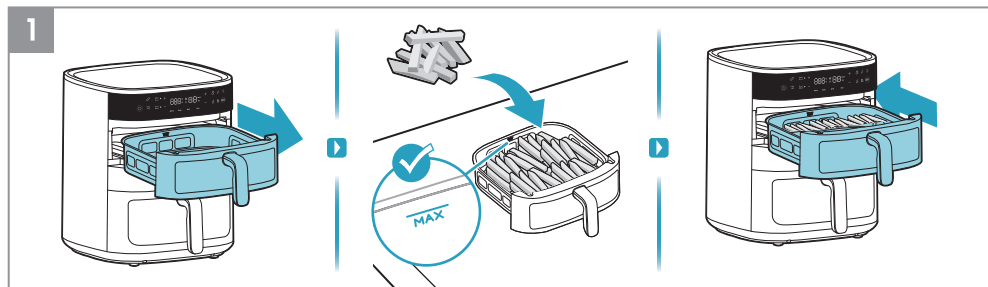

1. Vispirms izvelciet ārā augšējo grozu un ievietojiet tajā pārtiku, piemēram, frī kartupeļus.

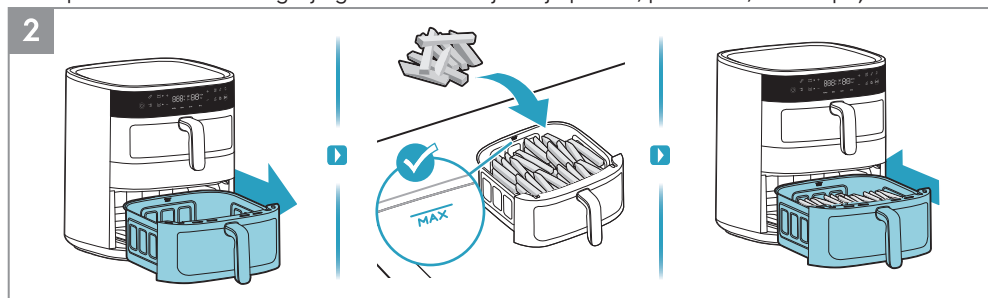

2. Pēc tam izvelciet ārā apakšējo grozu un ievietojiet tajā pārtiku, piemēram, frī kartupeļus.



3. Nospiediet ieslēgšanas/Izslēgšanas pogu. Vispirms atlasiet saites funkciju. Tad atlasiet vēlamo gatavošanas metodi, piemēram, gaisa fritēšanas funkciju. Noregulējiet laiku un temperatūru pēc vajadzības vai atlasiet kādu no iepriekš iestatītajām receptēm. Visbeidzot nospiediet pogu Palaist/Pauze.

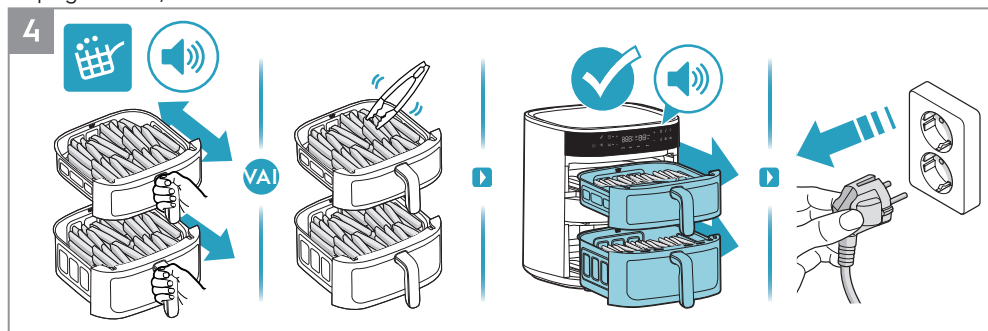

4. Kad gatavošanas procesa laikā iedegas "Sakratīšanas atgādinājuma" ikona un atskan pikstiens, ar karstumizturīgu rīku palīdzību apgrieziet pārtiku otrādi vai nedaudz viegli sakratiet fritēšanas grozā esošo pārtiku. Beidzoties gatavošanas laikam, ierīce dos pikstienu skaņas signālu. Pēc lietošanas atvienojiet ierīci no elektrotīkla.

Lietošana - Sinhronas pabeigšanas funkcija

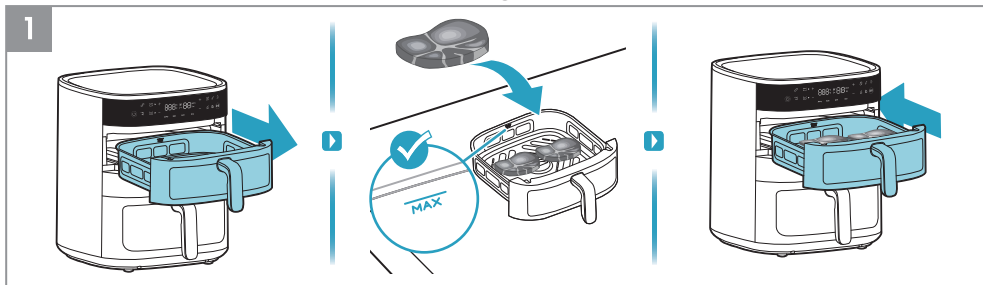

1. Vispirms izvelciet ārā augšējo grozu un ievietojiet tajā pārtiku, piemēram, steiku.

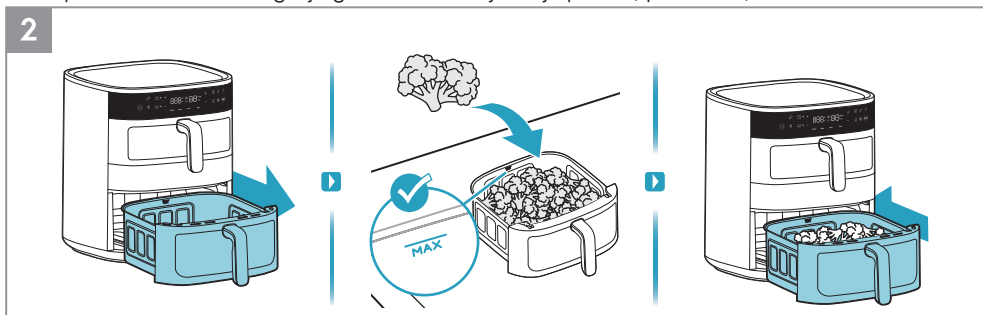

2. Pēc tam izvelciet ārā apakšējo grozu un ievietojiet tajā pārtiku, piemēram, brokolus.



3. Nospiediet Ieslēgšanas/Izslēgšanas pogu. Atlasiet Sinhronas pabeigšanas funkciju. Vispirms atlasiet augšējo grozu, tad atlasiet vēlamo gatavošanas metodi, piemēram, Gaisa fritēšanas funkciju. Noregulējiet laiku un temperatūru pēc vajadzības vai atlasiet kādu no iepriekš iestatītajām receptēm, piemēram, Steiks.



4. Tad atlasiet apakšējo grozu, atlasiet vēlamo gatavošanas metodi, piemēram, Gaisa fritēšanas funkciju. Noregulējiet laiku un temperatūru pēc vajadzības vai atlasiet kādu no iepriekš iestatītajām receptēm. Visbeidzot nospiediet pogu Palaist/Pauze.

- EN
- BG
- CZ
- DE
- DK
- EE
- FI
- FR
- GR
- HR
- HU
- IT
- LT
- LV
- NO
- NL
- PL
- PT
- RO
- RU
- SE
- SI
- SK
- SR
- TR
- UA
- ES
- GE
- AL

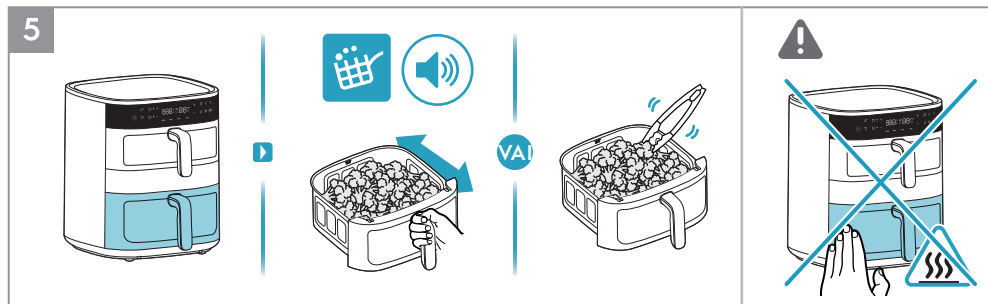

5. Vispirms par prioritāti gatavošanai tiks noteikts apakšējais grozs, kura gatavošanas laiks ir ilgāks. Kad gatavošanas procesa laikā iedegas "Sakratīšanas atgādinājuma" ikona un atskan pikstiens, ar karstumizturīgu rīku palīdzību apgrieziet pārtiku otrādi vai nedaudz viegli sakratiet fritēšanas grozā esošo pārtiku.

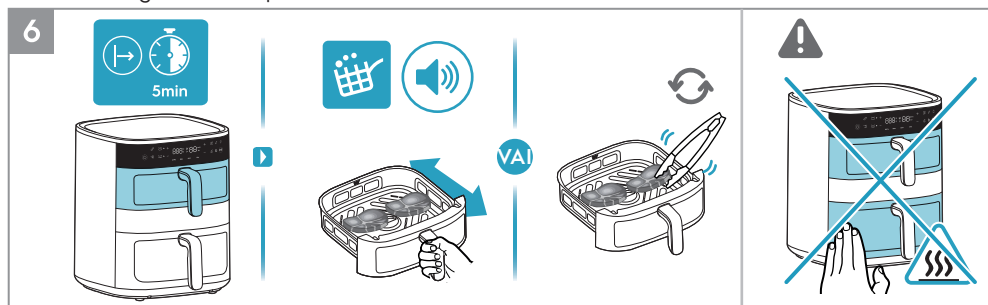

6. Tad gatavošanu sāks augšējais grozs, kura gatavošanas laiks ir īsāks. Kad gatavošanas procesa laikā iedegas "Sakratīšanas atgādinājuma" ikona un atskan pikstiens, ar karstumizturīgu rīku palīdzību apgrieziet pārtiku otrādi vai nedaudz viegli sakratiet fritēšanas grozā esošo pārtiku.

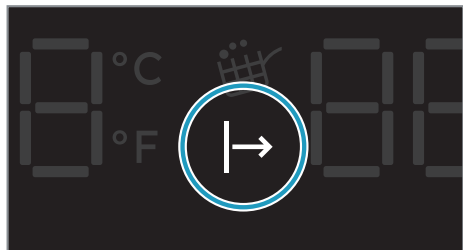

Laikas līdz gatavošanai indikators

Kad aktivizēta "Sinhronas pabeigšanas funkcija", grozs, kura gatavošanas laiks ir īsāks, nogaidīs ar gatavošanu, līdz grozs, kura gatavošanas laiks ir ilgāks, būs kādu laiku veicis gatavošanu, lai abi grozi varētu pabeigt gatavošanu vienlaicīgi. Šajā laikā līdz gatavošanas sākumam iedegsies "Laikas līdz gatavošanai indikators".

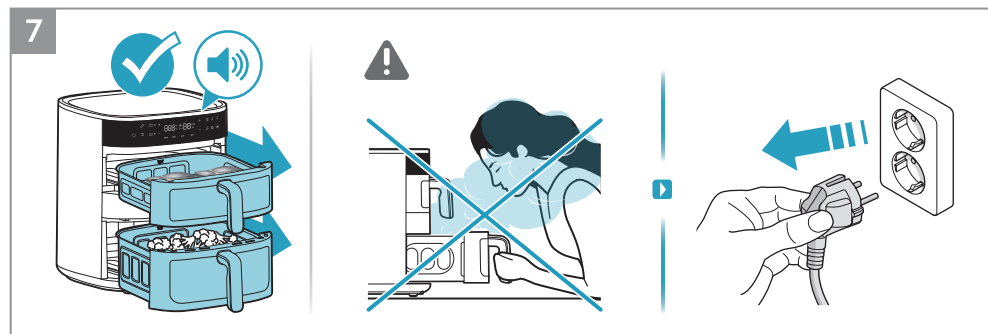

7. Beidzoties gatavošanas laikam, ierīce dos pikstienu skaņas signālu. Pēc lietošanas atvienojiet ierīci no elektrotilka.

Tīrīšana

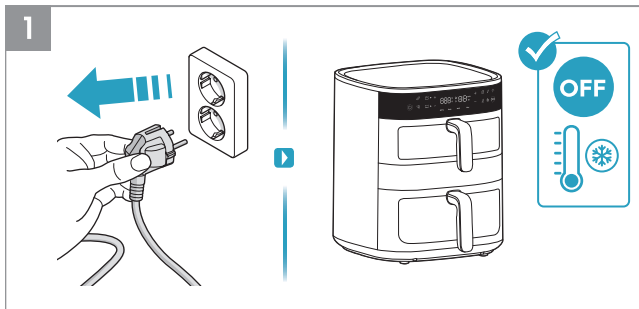

1. Pirms tīrīšanas vienmēr atvienojiet ierīci no elektrotīkla un nogaidiet līdz tā atdziest.
2. Noslaukiet ierīces ārpusi ar mīkstu drānu.

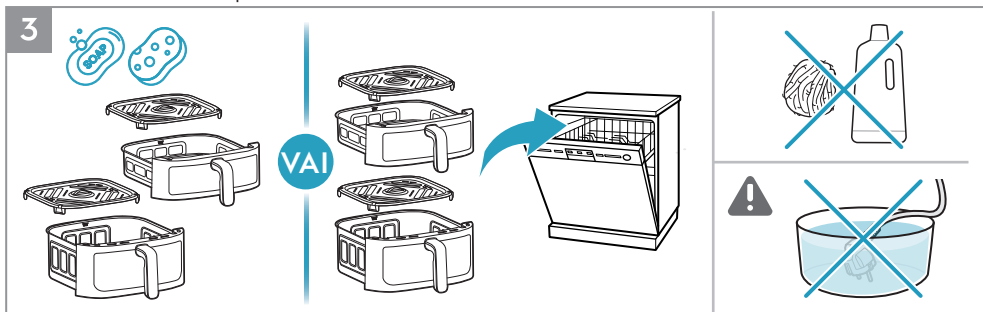
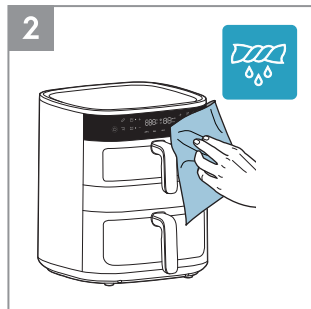

3. Tīriet pannu un režģi ar siltu ūdeni un trauku mazgāšanas līdzekli, vai ielieciet to trauku mazgājamā mašīnā.

▲PIEZĪME: Nelietojiet abrazīvus tīrīšanas līdzekļus vai metāla instrumentus, lai aizsargātu nepiedegošo pārklājumu.

UZMANĪBU: Nekad neiegremdējiet ierīci, tās vadu vai kontaktdakšu ūdenī vai jebkādā citā šķidrumā.

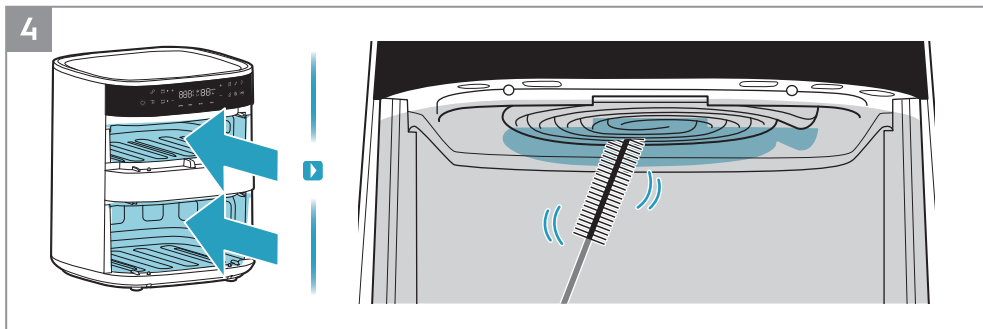











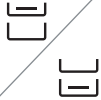



















































4. Sildelementu tīriet ar tīrīšanas birstīti.

PIEZĪME: Pirms sildelementa tīrīšanas pārlicinieties, ka ierīce ir pilnībā atdzisusi.

EN
BG
CZ
DE
DK
EE
FI
FR
GR
HR
HU
IT
LT
LV
NO
NL
PL
PT
RO
RU
SE
SI
SK
SR
TR
UA
ES
GE
AL

Gatavošanas ceļvedis

							
AirFry	7mm/10mm 	4l 	400g	180°C	18min		
		7l 	400g	180°C	18min		
AirFry		4L 	400g	170°C	8min		
		7L 	400g	170°C	10min		
AirFry		4l 	400g/2gab.	140°C	15min		
		7L 	400g/2gab.	140°C	15min		
AirFry		4l 	1000g/8gab.	180°C	28min		
		7l 	1000g/8gab.	180°C	28min		
AirFry		4l 	400g/2gab.	200°C	10min		
		7l 	400g/2gab.	200°C	10min		
AirFry	 	4l 	220g/6collas	160°C	12min		
		7l 	220g/6collas	160°C	14min		

Recipe							
AirFry		 4l	1200g	180°C	55min		
AirFry		 7l	400g/9gab.	160°C	20min		
Grill		 4l	180g/4gab.	180°C	8min		
		 7l	180g/4gab.	180°C	9min		
Dry		 4l	180g	80°C	3h		
		 7l	180g	80°C	3h		
Dry		 4l	200g	80°C	3h		
		 7l	200g	80°C	3h		

- EN
- BG
- CZ
- DE
- DK
- EE
- FI
- FR
- GR
- HR
- HU
- IT
- LT
- LV**
- NO
- NL
- PL
- PT
- RO
- RU
- SE
- SI
- SK
- SR
- TR
- UA
- ES
- GE
- AL

Kā rīkoties, ja ...

Problēma	Pārbaudiet, vai...
Jūs nevarat ierīci ieslēgt vai darbināt	<ul style="list-style-type: none"> • Ierīce ir pareizi pievienota elektrotīklam. • Grozi atrodas pareizajā pozīcijā. Lai varētu ieslēgties barošana, nodrošiniet, lai tie būtu iestumti ierīcē pilnībā līdz galam. • Gatavošanas laiks ir iestatīts.
Jūs nevarat ieslidināt grozu ierīcē.	<ul style="list-style-type: none"> • Grozs ir piepildīts, pārsniedzot tā maksimālo ietilpību. • Grozs ir novietots pareizi. Ievietojot to ierīcē, ir jāatskan klikšķim. • Zem groza ir kāds priekšmets, kas ir šķērslis tā pareizai aizvēršanai.
No ierīces nāk balti dūmi.	<ul style="list-style-type: none"> • Pārtika, ko gatavojat, ir pārāk taukaina. • Grozs, režģis un sildelements ir tīri.
Displejs rāda E1	• Augšējā groza ķēde atvērta.
Displejs rāda E2	• Augšējā groza īssavienojums.
Displejs rāda E3	• Apakšējā groza ķēde atvērta.
Displejs rāda E4	• Apakšējā groza īssavienojums.
Displejs rāda E5	• Vadības PCBA komunikācijas kļūme.
Displejs rāda E6	• Strāvas PCBA komunikācijas kļūme.

* Gadījumā, ja displejā tiek rādīti kļūdu kodi, ierīci ir jāremontē Servisa centrā.

Tehniskie dati

Izstrādājums	Gaisa frīteris
Modelis	EAFD11B
Spriegums (V~)	220 V - 240 V
Jauda (W)	2700 W
Frekvence (Hz)	50 - 60 Hz
Tilpums	4 l + 7 l



Bruksanvisning

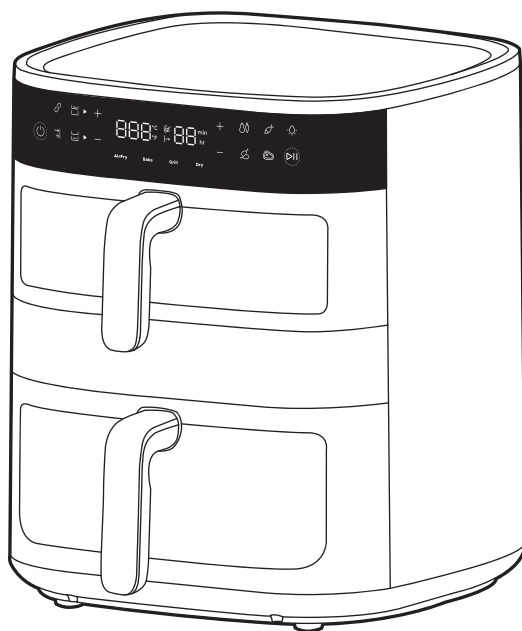

800 dobbel airfryer

Generell oversikt

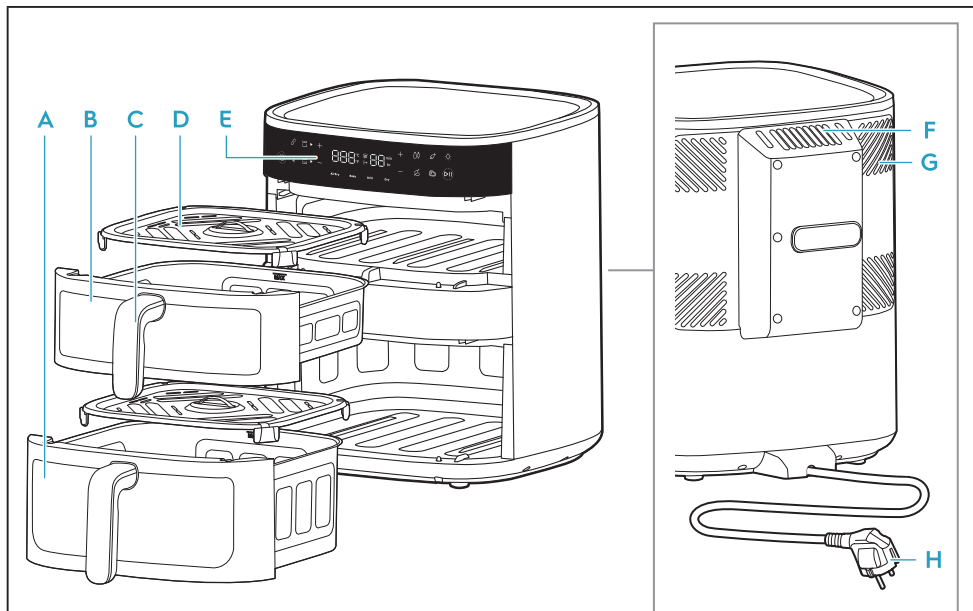

- | | | | |
|-------------------------|----------------------|------------------------|-----------------------|
| A Bunnkurv (7 l) | C Kurvhåndtak | E Kontrollpanel | G Kjølesystem |
| B Toppkurv (4 l) | D Risten | F Luftutløp | H Hovedledning |

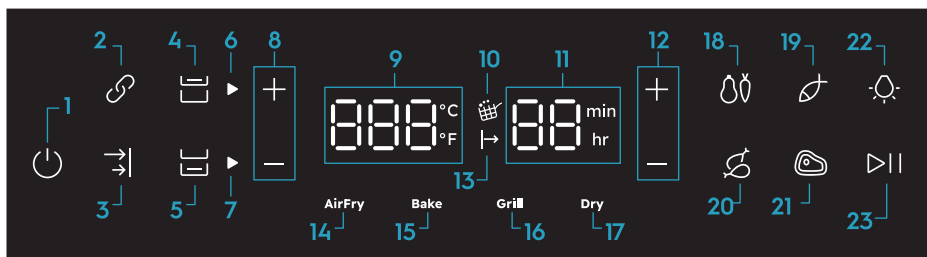

- | | | | |
|---------------------------------|---|----------------------------|-----------------|
| 1. På/Av | 8. Temperaturstyring | 13. Venter på tilberedning | 19. Fisk |
| 2. Koblingsfunksjon | 9. Temperaturindikator (40-200 °C) | 14. AirFry-funksjon | 20. Kylling |
| 3. Sluttsynkroniseringsfunksjon | 10. Ristepåminnelse | 15. Stekefunksjon | 21. Biff |
| 4. Toppkurvstyring | 11. Tidsindikator (AirFry: 1-99 minutter, dehydrere: 1-5 timer) | 16. Grillfunksjon | 22. Lysstyring |
| 5. Bunnkurvstyring | 12. Tidsstyring | 17. Tørkefunksjon | 23. Start/Pause |
| 6. Toppkurvindikator | | 18. Grønnsaker | |
| 7. Bunnkurvindikator | | | |

Før første bruk

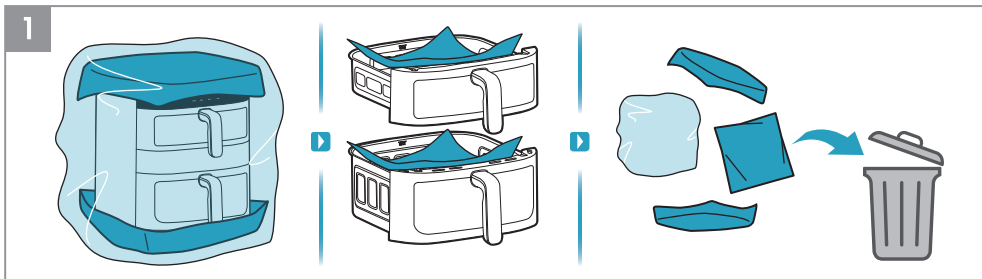

1. Fjern all emballasje og beskyttelsesmateriale.

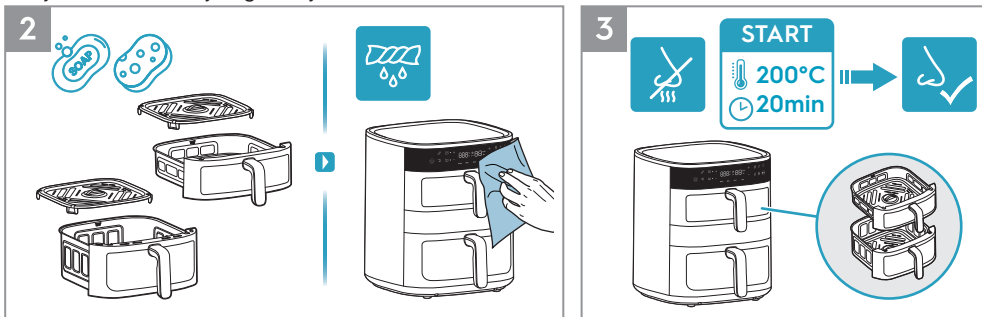

2. Rengjør pannen og risten med varmt vann og oppvaskmiddel. Tørk av apparatet innvendig og utvendig med en myk klut.

3. Det er normalt at en ny enhet avgir en lukt de første gangene den brukes. Kjør den tomme friterkokeren ved 200 °C i 20 minutter før første gangs bruk for å unngå dette.

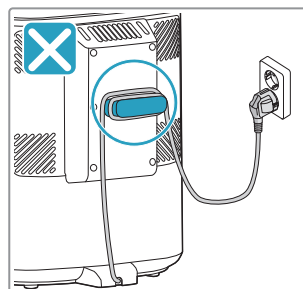
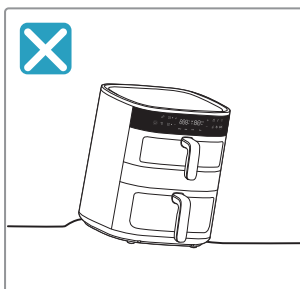
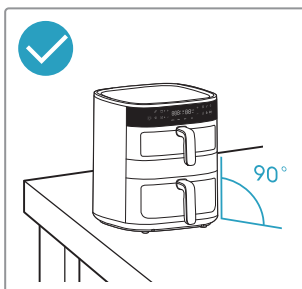
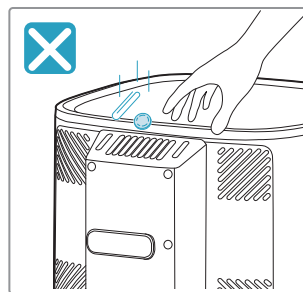
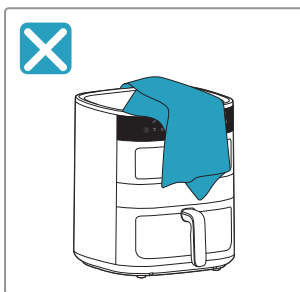

! Sikkerhetsforholdsregler







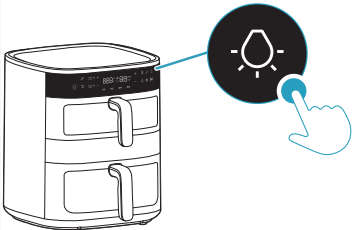
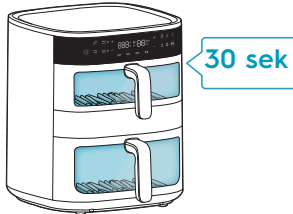









EN
BG
CZ
DE
DK
EE
FI
FR
GR
HR
HU
IT
LT
LV
NO
NL
PL
PT
RO
RU
SE
SI
SK
SR
TR
UA
ES
GE
AL

EN
BG
CZ
DE
DK
EE
FI
FR
GR
HR
HU
IT
LT
LV
NO
NL
PL
PT
RO
RU
SE
SI
SK
SR
TR
UA
ES
GE
AL







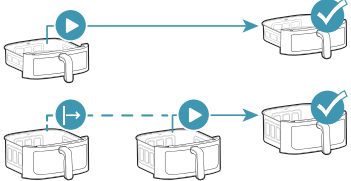







Lysstyring og temperaturskalaomregning

 <p>Lysstyring</p>		
<p>°C/°F</p> <p>Temperaturskalaomregning</p>		

Kurvvalg

	 <p>4l</p>	 <p>7l</p>	
 <p>Toppkurv</p>			
 <p>Bunnkurv</p>			
 <p>Koblingsfunksjon</p>			
 <p>Sluttsynkroniseringsfunksjon</p>			

Forhåndsinnstilte funksjoner

					
AirFry	180°C	15min	60-200°C	1-99min	
	170°C	10min	60-200°C	1-99min	
	140°C	15min	60-200°C	1-99min	
	180°C	30min	60-200°C	1-99min	
	200°C	10min	60-200°C	1-99min	
Bake	170°C	15min	60-200°C	1-99min	
Grill	200°C	5min	60-200°C	1-99min	
Dry	80°C	5t	40-80°C	1-5t	

Før tilberedning

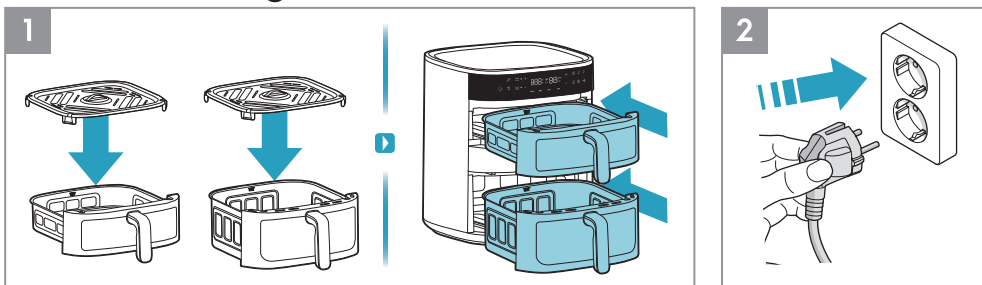

1. Før hver tilberedning må du plassere risten i kurven (den varmebestandige silikonfoten på risten trenger ikke fjernes) og skyve kurven helt inn i apparatet.
2. Sett strøpluggen inn i strømuttaket.

Hvordan bruke - Enkel kurv

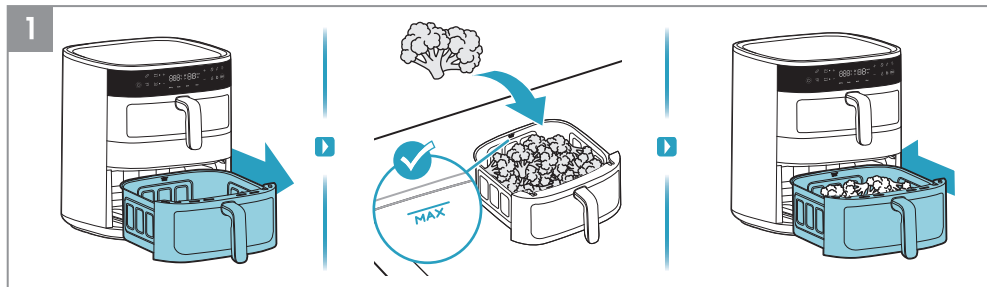

1. Trekk ut en kurv og plasser den på et stabilt underlag, legg maten i kurven og følg kapasitetsangivelsen "MAX". Skyv deretter kurven med maten helt tilbake inn i apparatet.



2. Trykk på Av/På-knappen. Velg først kurven med mat. Velg deretter ønsket tilberedningsmetode, for eksempel AirFry-funksjonen. Juster tid og temperatur etter smak, eller velg en av de forhåndsinnstilte oppskriftene, for eksempel "Grønnsaker". Til slutt trykker du på Start/Pause-knappen.

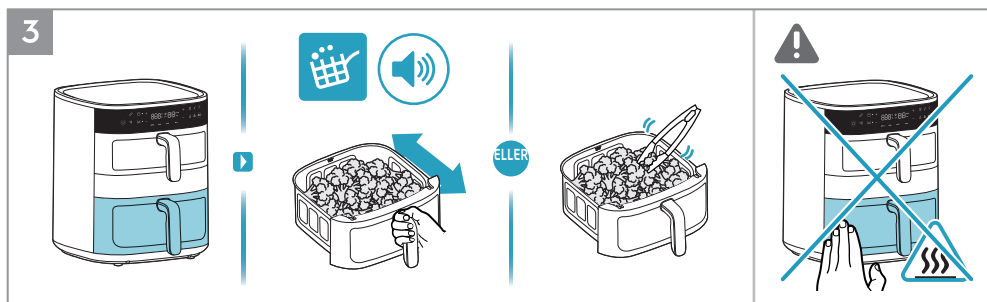

3. Når ikonet "Ristepåminnelse" lyser og piper under tilberedningen, bruk varmebestandige redskaper til å snu maten én gang eller rist forsiktig på maten i stekekurven.

⚠ **FORSIKTIG:** Ikke rist stekekurven kraftig for å forhindre at maten spruter og forårsaker brannskader.

⚠ **FORSIKTIG:** Vær forsiktig med varme overflater når apparatet er i bruk.

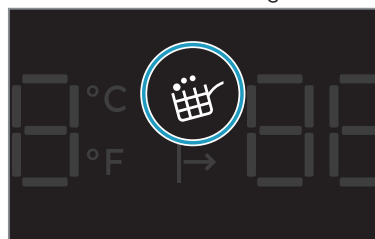

Ristepåminnelse

"Ristepåminnelse" aktiveres under AirFry-funksjonen og forhåndsinnstilte oppskrifter, for eksempel grønnsaker, fisk, kyllinglår og biff.

Når det er på tide å riste eller snu maten, vil

"Ristepåminnelse"-ikonet lyse og blinke i ett minutt, mens en pipelyd gjentas tre ganger.

"Ristepåminnelsen" er ikke obligatorisk, og tilberedningen fortsetter som vanlig selv om maten ikke blir snudd eller ristet.

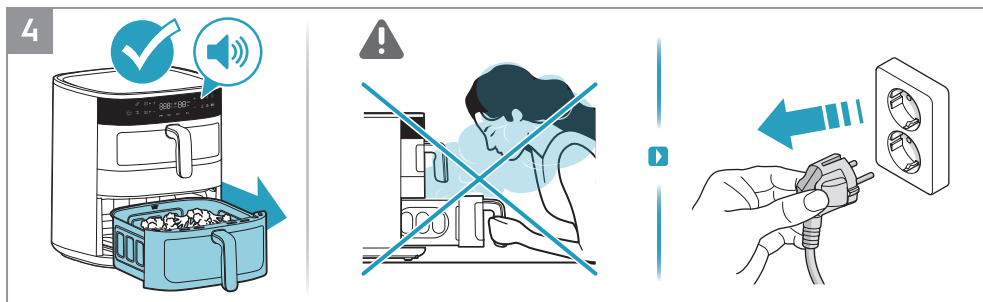

4. Når tilberedningstiden er over, vil apparatet avgi en pipelyd. Fjern kurven forsiktig og sett den på en varmebestandig overflate. Koble apparatet fra strømmettet etter bruk.

⚠ **FORSIKTIG:** Det kan komme varm damp ut av kurven når den åpnes midt i eller på slutten av tilberedningen. Sørg for at ansiktet, armene og hendene er unna dampen når du åpner den.

Hvordan bruke - Top- + Bunnkurv

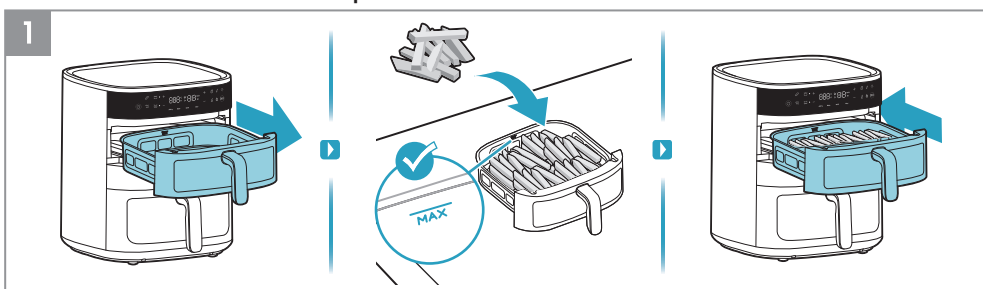

1. Først trekker du ut toppkurven og legger maten i kurven, for eksempel pommes frites.

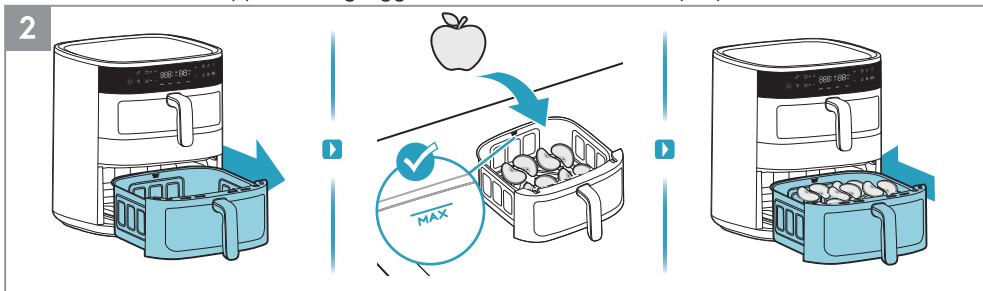

2. Deretter trekker du ut den bunnkurven og legger maten i kurven, for eksempel epleskiver.



3. Trykk på Av/På-knappen. Velg først toppkurven. Velg deretter ønsket tilberedningsmetode, for eksempel AirFry-funksjonen. Juster tid og temperatur etter smak, eller velg en av de forhåndsinnstilte oppskriftene, for eksempel "Grønnsaker". Til slutt trykker du på Start/Pause-knappen.

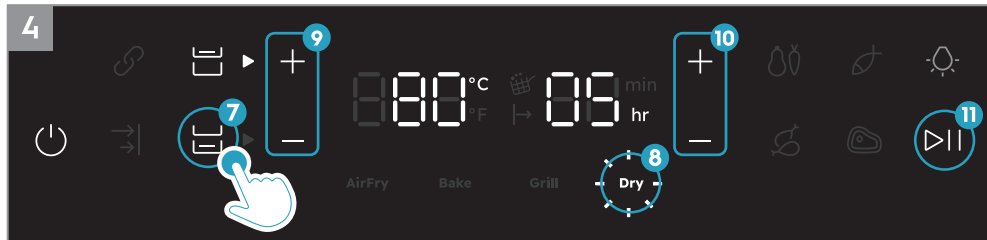

4. Velg deretter bunnkurven. Velg deretter ønsket tilberedningsmetode, for eksempel tørkefunksjonen. Juster tid og temperatur etter smak. Til slutt trykker du på Start/Pause-knappen.

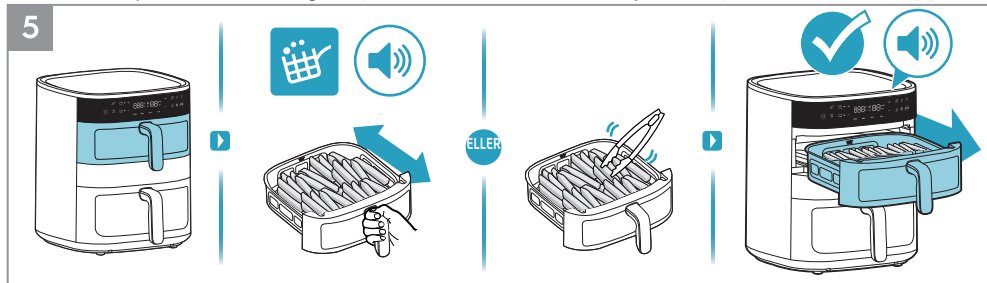

5. Når ikonet "Ristepåminnelse" lyser og piper under tilberedningen, bruk varmebestandige redskaper til å snu maten én gang eller rist forsiktig på maten i stekekurven. Når koketiden for toppkurven er over, vil apparatet avgi en pipelyd.

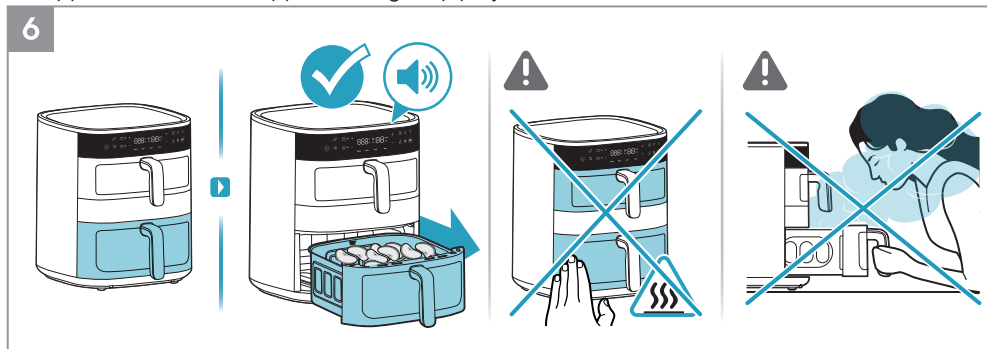

6. Når koketiden for bunnkurven er over, vil apparatet avgi en pipelyd.

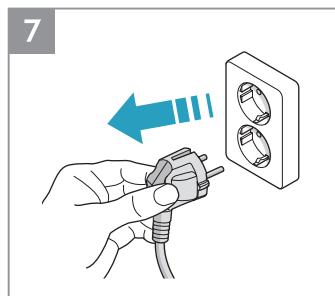

7. Koble apparatet fra strømmettet etter bruk.

Hvordan bruke - Koblingsfunksjon

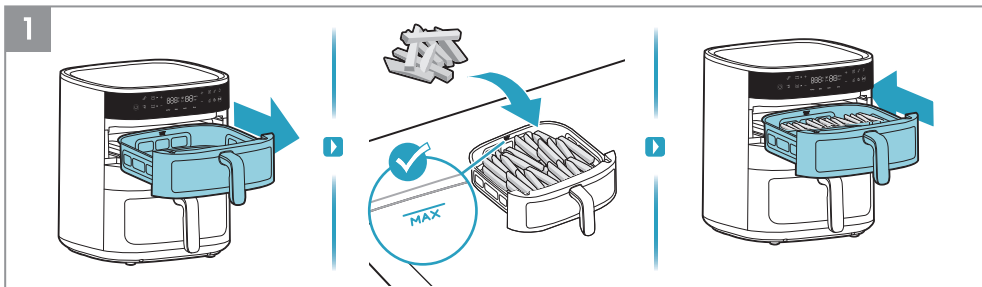

1. Først trekker du ut toppkurven og legger maten i kurven, for eksempel pommes frites.

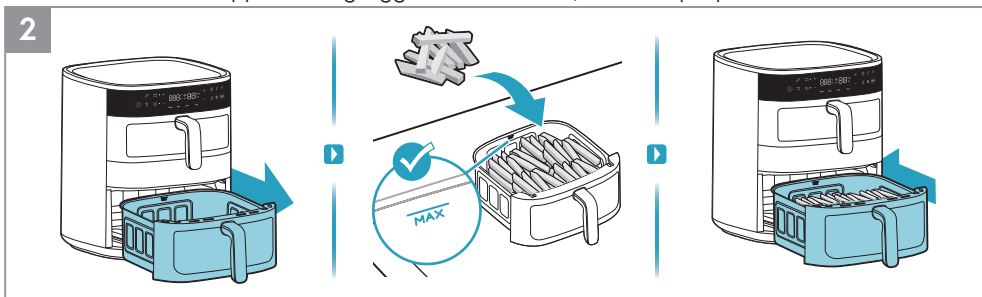

2. Deretter trekker du ut bunnkurven og legger maten i kurven, for eksempel pommes frites.



3. Trykk på Av/På-knappen. Velg først koblingsfunksjonen. Velg deretter ønsket tilberedningsmetode, for eksempel AirFry-funksjonen. Juster tid og temperatur etter smak, eller velg en av de forhåndsinnstilte oppskriftene. Til slutt trykker du på Start/Pause-knappen.

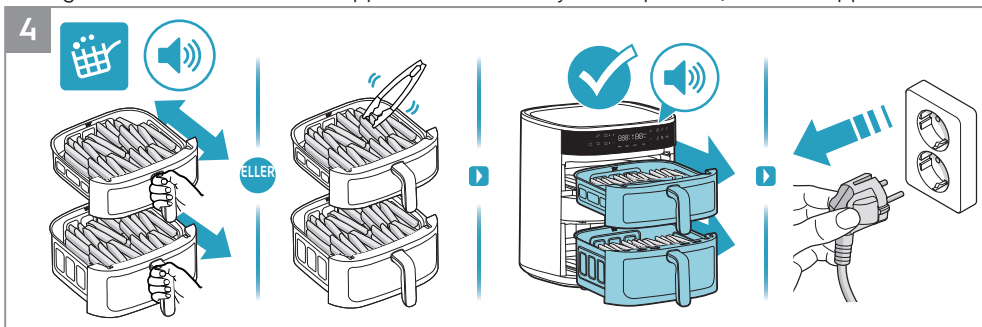

4. Når ikonet "Ristepåminnelse" lyser og piper under tilberedningen, bruk varmebestandige redskaper til å snu maten én gang eller rist forsiktig på maten i stekekurven. Når tilberedningstiden er over, vil apparatet avgi en pipelyd. Koble apparatet fra strømmettet etter bruk.

- EN
- BG
- CZ
- DE
- DK
- EE
- FI
- FR
- GR
- HR
- HU
- IT
- LT
- LV
- NO
- NL
- PL
- PT
- RO
- RU
- SE
- SI
- SK
- SR
- TR
- UA
- ES
- GE
- AL

EN
BG
CZ
DE
DK
EE
FI
FR
GR
HR
HU
IT
LT
LV
NO
NL
PL
PT
RO
RU
SE
SI
SK
SR
TR
UA
ES
GE
AL

Hvordan bruke - Sluttsynkroniseringsfunksjon

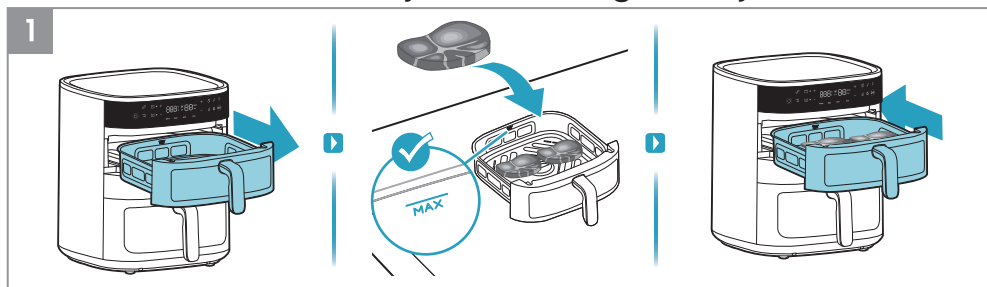

1. Først trekker du ut toppkurven og legger maten i kurven, for eksempel biff.

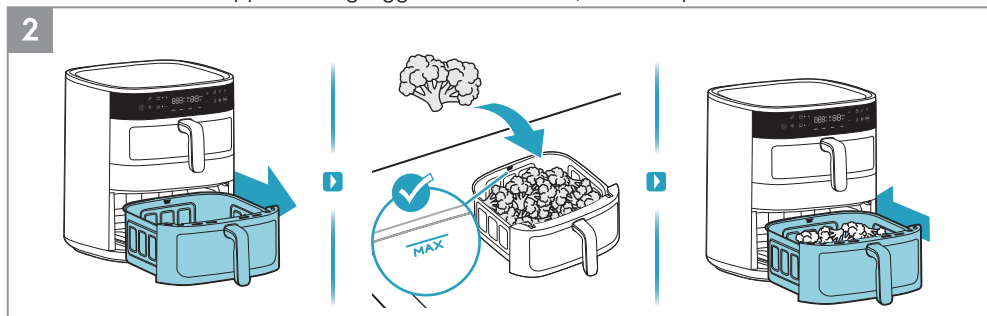

2. Deretter trekker du ut bunnkurven og legger maten i kurven, for eksempel brokkoli.



3. Trykk på Av/På-knappen. Velg sluttsynkroniseringsfunksjonen. Velg først toppkurven, og velg deretter ønsket tilberedningsmetode, for eksempel AirFry-funksjonen. Juster tid og temperatur etter smak, eller velg en av de forhåndsinnstilte oppskriftene, for eksempel "Biff".



4. Velg deretter bunnkurven, velg ønsket tilberedningsmetode, for eksempel AirFry-funksjonen. Juster tid og temperatur etter smak, eller velg en av de forhåndsinnstilte oppskriftene. Til slutt trykker du på Start/Pause-knappen.

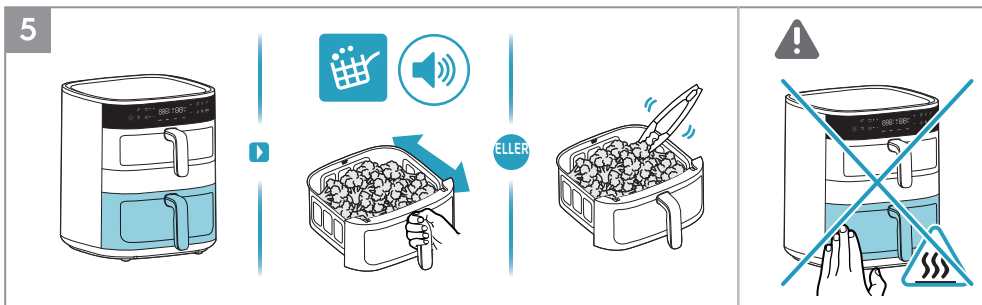

5. Tilberedning av bunnkurven med lengre innstillingstid vil prioriteres først. Når ikonet "Ristepåminnelse" lyser og piper under tilberedningen, bruk varmebestandige redskaper til å snu maten én gang eller rist forsiktig på maten i stekekurven.

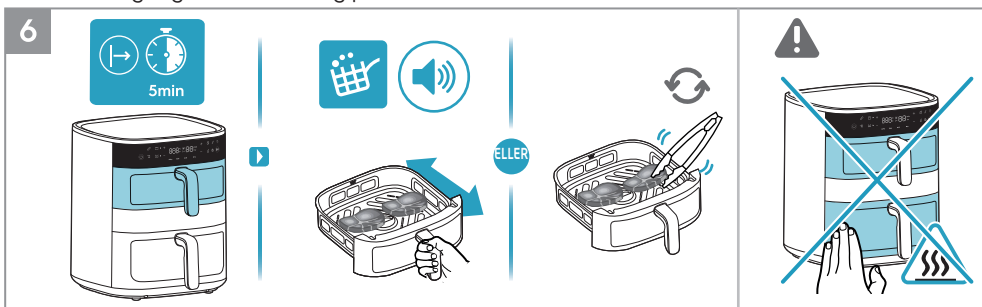

6. Deretter begynner tilberedningen av toppkurven med kortere innstillingstid. Når ikonet "Ristepåminnelse" lyser og piper under tilberedningen, bruk varmebestandige redskaper til å snu maten én gang eller rist forsiktig på maten i stekekurven.

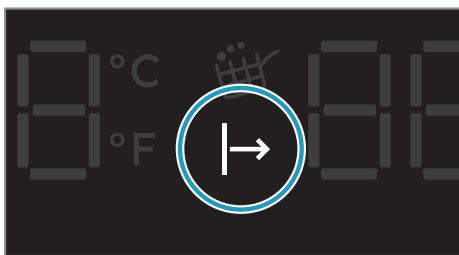

Indikator for venting på tilberedning

Når "Sluttsynkroniseringsfunksjonen" er aktivert, vil kurven med kortere tilberedningstid vente med tilberedningen til kurven med lengre tilberedningstid har tilberedt en stund, slik at begge kurvene kan avslutte tilberedningen samtidig. I denne perioden vil "Indikator for venting på tilberedning" lyse til tilberedningen starter.

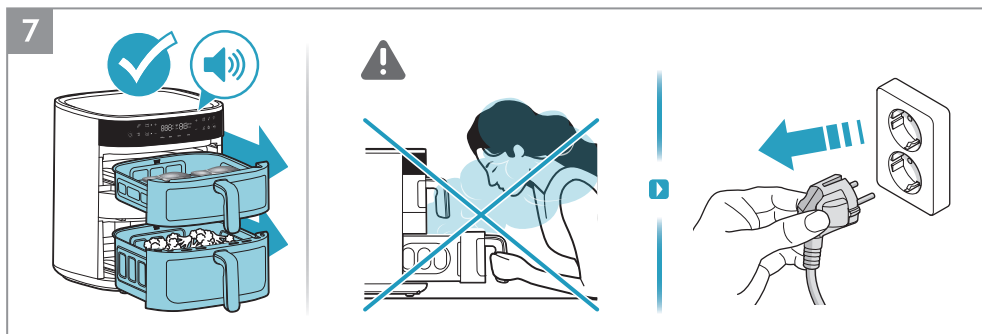

7. Når tilberedningstiden er over, vil apparatet avgi en pipelyd. Koble apparatet fra strømmettet etter bruk.

Rengjøring

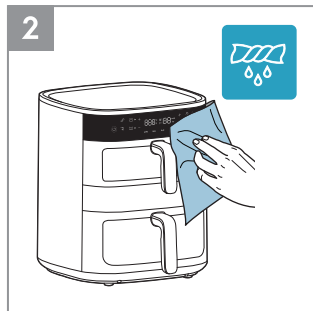
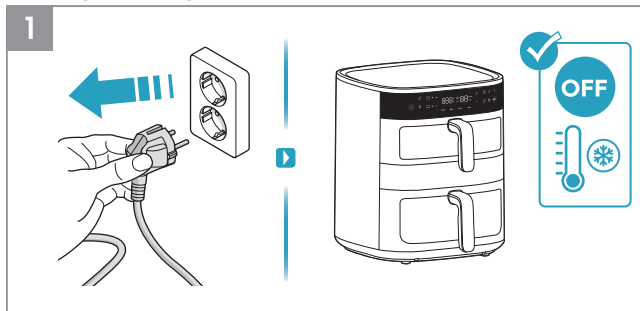

1. Koble alltid apparatet fra strømmettet og vent til det er avkjølt før du rengjør det
2. Tørk av utsiden av apparatet med en myk klut

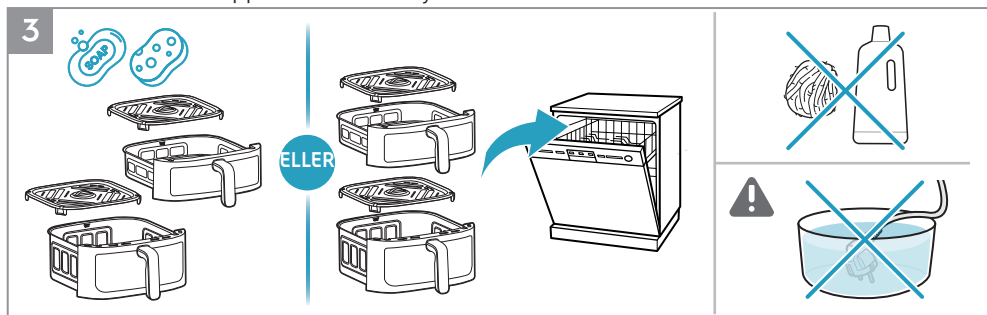

3. Rengjør pannen og risten med varmt vann og oppvaskmiddel, eller legg dem i oppvaskmaskinen.
▲MERK: Unngå å bruke slipende rengjøringsmidler eller metallverktøy for å beskytte non-stick-belegget.



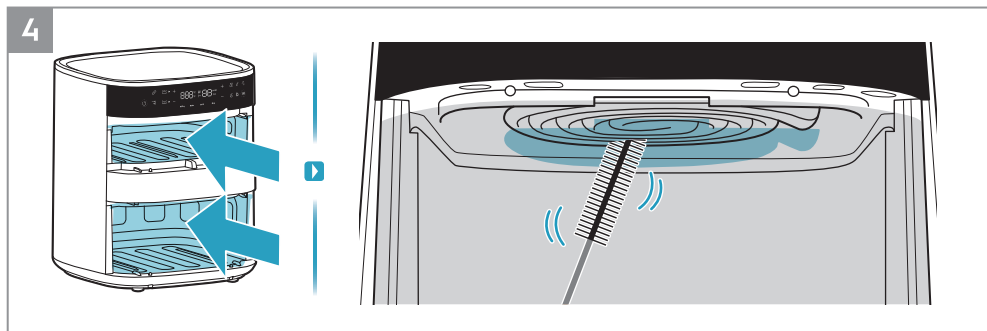

























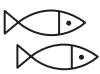







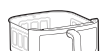

FORSIKTIG: Produktets ledning eller støpsel må aldri dyppes i vann eller andre væsker.



4. Rengjør varmeelementet med en rengjøringsbørste.













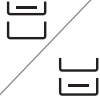











MERK: Sørg for at apparatet er helt avkjølt før du rengjør varmeelementet

Tilberedningsguide

 Recipe	 						
AirFry	7mm/10mm 	4l 	400g	180°C	18min		
		7l 	400g	180°C	18min		
AirFry		4l 	400g	170°C	8min		
		7l 	400g	170°C	10min		
AirFry		4l 	400g/2stk.	140°C	15min		
		7l 	400g/2stk.	140°C	15min		
AirFry		4l 	1000g/8stk.	180°C	28min		
		7l 	1000g/8stk.	180°C	28min		
AirFry		4l 	400g/2stk.	200°C	10min		
		7l 	400g/2stk.	200°C	10min		
AirFry		4l 	220g/15 cm	160°C	12min		
		7l 	220g/15 cm	160°C	14min		

- EN
- BG
- CZ
- DE
- DK
- EE
- FI
- FR
- GR
- HR
- HU
- IT
- LT
- LV
- NO**
- NL
- PL
- PT
- RO
- RU
- SE
- SI
- SK
- SR
- TR
- UA
- ES
- GE
- AL

EN
BG
CZ
DE
DK
EE
FI
FR
GR
HR
HU
IT
LT
LV
NO
NL
PL
PT
RO
RU
SE
SI
SK
SR
TR
UA
ES
GE
AL

							
AirFry		7l 	1200g	180°C	55min		
AirFry		7l 	400g/9stk.	160°C	20min		
Grill		4l 	180g/4stk.	180°C	8min		
		7l 	180g/4stk.	180°C	9min		
Dry		4l 	180g	80°C	3t		
		7l 	180g	80°C	3t		
Dry		4l 	200g	80°C	3t		
		7l 	200g	80°C	3t		

Hva gjør du hvis ...

Problem	Sjekk om ...
Du ikke kan aktivere eller bruke apparatet	<ul style="list-style-type: none">• Apparatet er riktig koblet til strømforsyningen.• Kurvene er i riktig posisjon. Sørg for at de er helt presset inn i apparatet for å aktivere strømforsyningen.• Tilberedningstiden er innstilt.
Du klarer ikke å skyve kurven inn i apparatet	<ul style="list-style-type: none">• Kurven er fylt over sin maksimale kapasitet• Kurven er plassert riktig. Den må klikke på plass når du setter den inn i enheten.• Det er et objekt under kurven som hindrer den i å lukkes ordentlig.
Det kommer hvit røyk ut av apparatet	<ul style="list-style-type: none">• Maten du lager er for fet• Kurven, risten og varmeelementet er rene.
Displayet viser E1	<ul style="list-style-type: none">• Åpen krets i toppkurven.
Displayet viser E2	<ul style="list-style-type: none">• Kortslutning i toppkurven.
Displayet viser E3	<ul style="list-style-type: none">• Åpen krets i bunnkurven.
Displayet viser E4	<ul style="list-style-type: none">• Kortslutning i bunnkurven.
Displayet viser E5	<ul style="list-style-type: none">• Kontroller-PCBA-kommunikasjonsfeil.
Displayet viser E6	<ul style="list-style-type: none">• Strøm-PCBA-kommunikasjonsfeil.

* Hvis displayet viser feilkoder, må apparatet repareres av et servicesenter.

Tekniske data

Produkt	Airfryer
Modell	EAFD11B
Spenning (V~)	220 V ~ 240 V
Effekt (W)	2700 W
Frekvens (Hz)	50 ~ 60 Hz
Kapasitet	4 L + 7 L



Handleiding

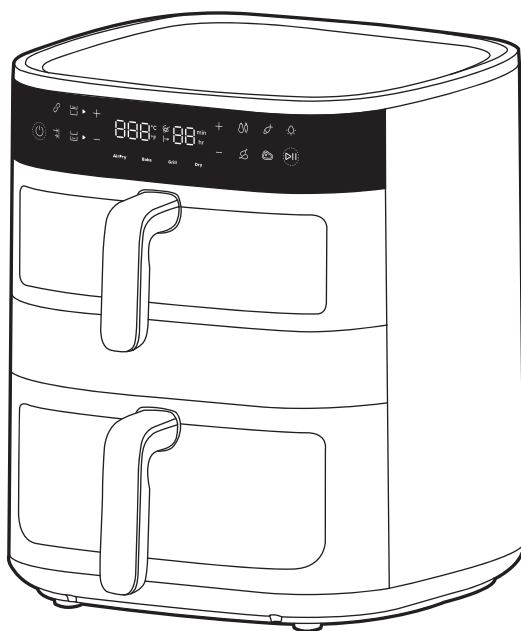

800 Air Fryer Dual

Algemene overzicht

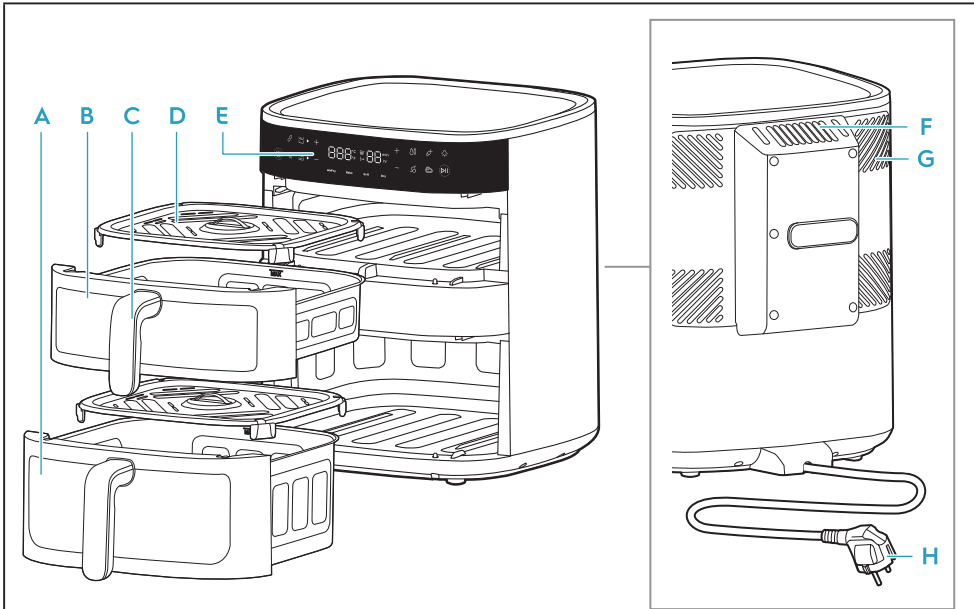

- | | | | |
|------------------------------|----------------------|---------------------------|----------------------|
| A Onderste mand (7 l) | C Mandhandvat | E Bedieningspaneel | G Koelsysteem |
| B Bovenste mand (4 l) | D Rooster | F Luchtuitlaat | H Hoofdkabel |

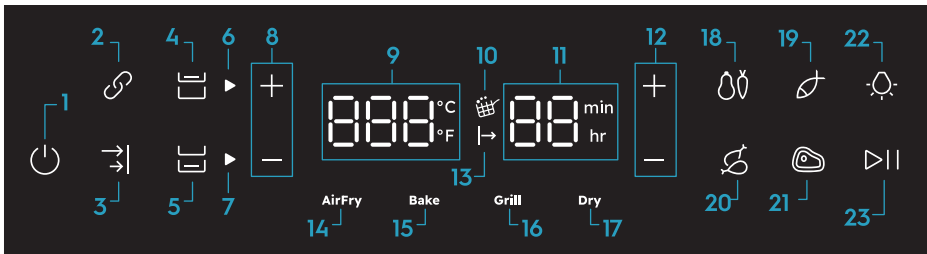

- | | | | |
|-------------------------------------|--|----------------------|--------------------|
| 1. Aan/uit | 7. Indicator onderste mand | 13. Wachten op koken | 20. Kip |
| 2. Koppelfunctie | 8. Temperatuurregelaar | 14. AirFry-functie | 21. Steak |
| 3. Synchronisatiefunctie beëindigen | 9. Temperatuurindicator (40-200°C) | 15. Bakfunctie | 22. Lichtregeling |
| 4. Bediening bovenste mand | 10. Schudherinnering | 16. Grillfunctie | 23. Afspelen/Pauze |
| 5. Bediening onderste mand | 11. Tijdindicator (AirFry: 1-99 min, Dehydrateren: 1-5h) | 17. Droogfunctie | |
| 6. Indicator bovenste mand | 12. Tijdcontrole | 18. Groenten | |
| | | 19. Vis | |

Voor het eerste gebruik

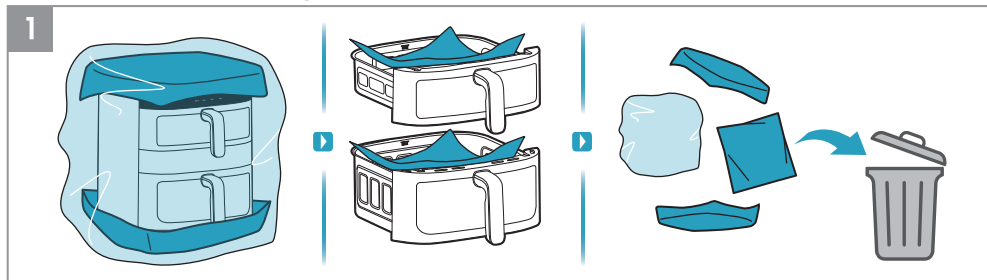

1. Verwijder alle verpakings- en beschermingsmateriaal.

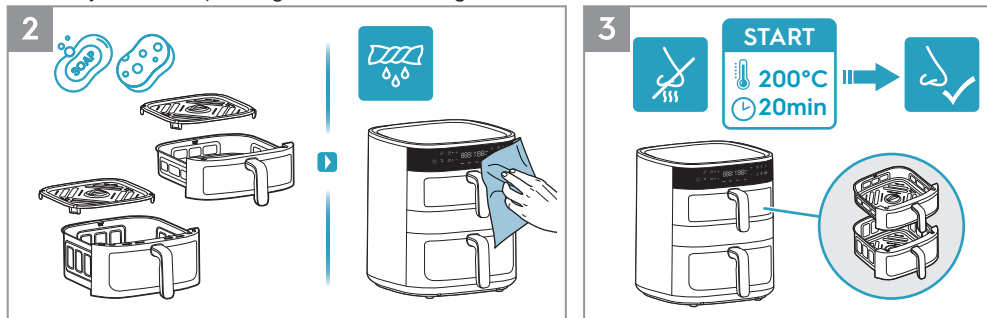

2. Reinig de pan en het rooster met warm water en afwasmiddel. Veeg de binnen- en buitenkant van het apparaat af met een zachte doek.

3. Het is normaal dat een nieuw apparaat de eerste paar keer dat het wordt gebruikt een geur afgeeft. Laat de lege airfryer voor het eerste gebruik 20 minuten op 200 °C draaien om dit te voorkomen.



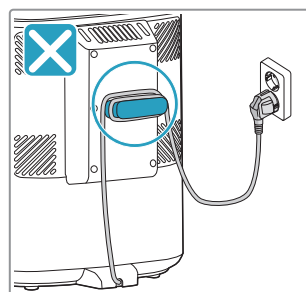
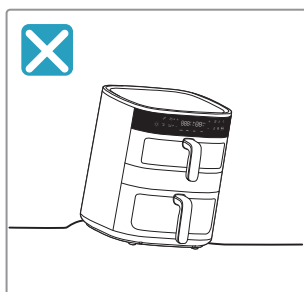
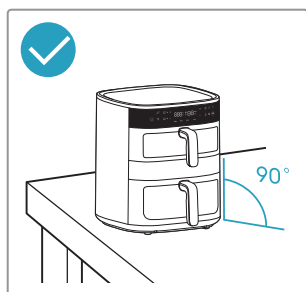
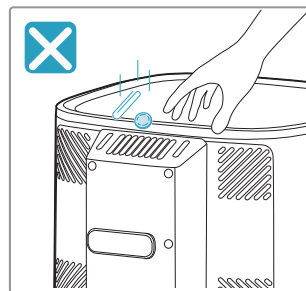
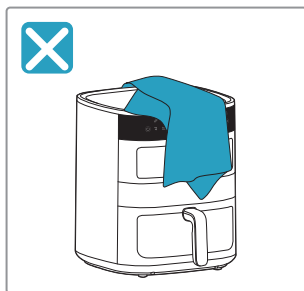
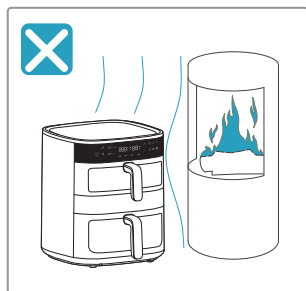



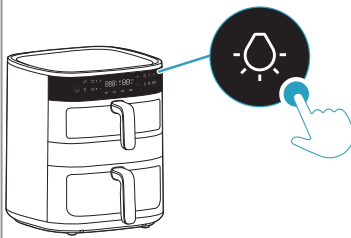
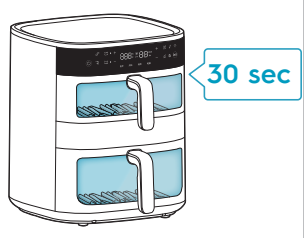
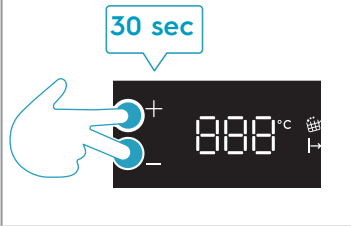
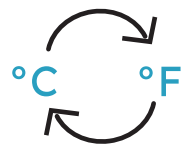



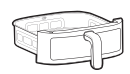
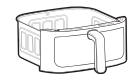

! Veiligheidsvoorschriften



Verlichtingsregeling en temperatuurschaalconversie





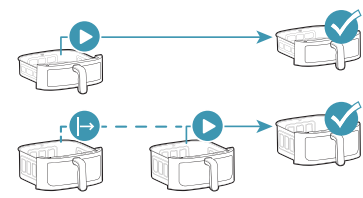





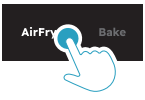



 <p>Verlichtingsregeling</p>		
<p>°C/°F</p> <p>Temperatuurschaalconversie</p>		

Mandselectie

	 <p>4l</p>	 <p>7l</p>	
 <p>Bovenste mand</p>			
 <p>Onderste mand</p>			
 <p>Koppelfunctie</p>			
 <p>Synchronisatiefunctie beëindigen</p>			

- EN
- BG
- CZ
- DE
- DK
- EE
- FI
- FR
- GR
- HR
- HU
- IT
- LT
- LV
- NO
- NL**
- PL
- PT
- RO
- RU
- SE
- SI
- SK
- SR
- TR
- UA
- ES
- GE
- AL

Vooraf ingestelde functies

					
Air Fry	180°C	15min	60-200°C	1-99min	
	170°C	10min	60-200°C	1-99min	
	140°C	15min	60-200°C	1-99min	
	180°C	30min	60-200°C	1-99min	
	200°C	10min	60-200°C	1-99min	
Bake	170°C	15min	60-200°C	1-99min	
Grill	200°C	5min	60-200°C	1-99min	
Dry	80°C	5h	40-80°C	1-5h	

Voor het koken

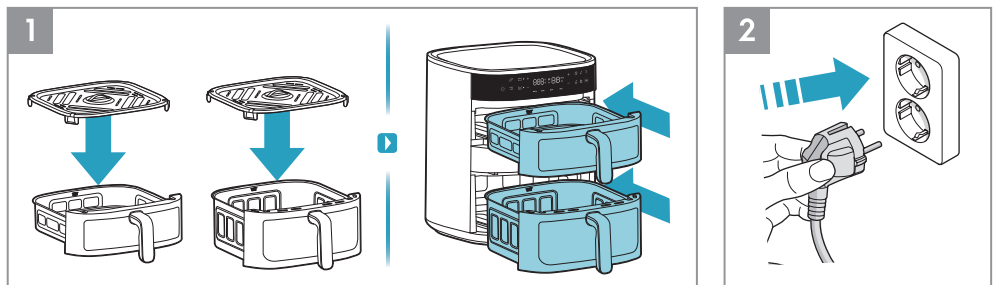

1. Plaats voor elke bereiding het rooster in de mand (het hittebestendige siliconen voetskussen van het rooster hoeft niet te worden verwijderd) en duw de mand volledig in het apparaat
2. Steek de stekker in het stopcontact

Gebruiksaanwijzing - Enkele mand

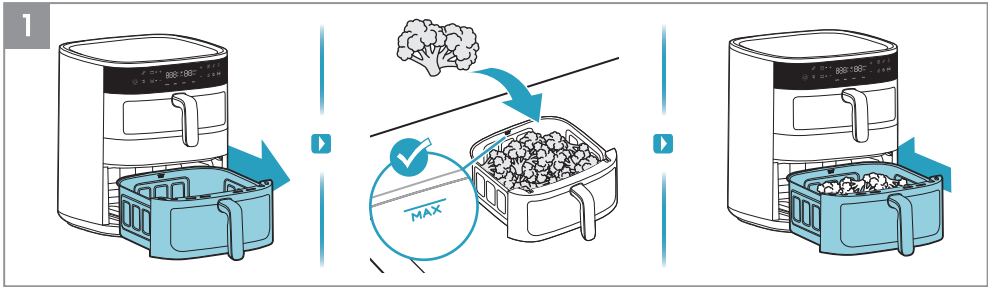

1. Trek één mand naar buiten en plaats de mand op een stabiel oppervlak. Plaats het eten en de mand en houd rekening met de aangegeven maximale capaciteit. Duw vervolgens de mand met eten volledig terug in het apparaat.

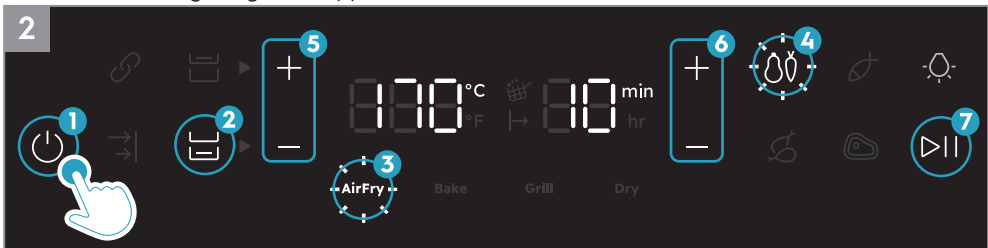

2. Druk de Aan/uit-knop. Selecteer eerst de mand met eten. Selecteer vervolgens de gewenste bereidingswijze, bijvoorbeeld de Air Fry-functie. Pas de tijd en temperatuur aan naar uw smaak of selecteer een van de vooraf ingestelde recepten, bijvoorbeeld Groenten. Druk als laatste op de knop Afspelen/Pauzeren.

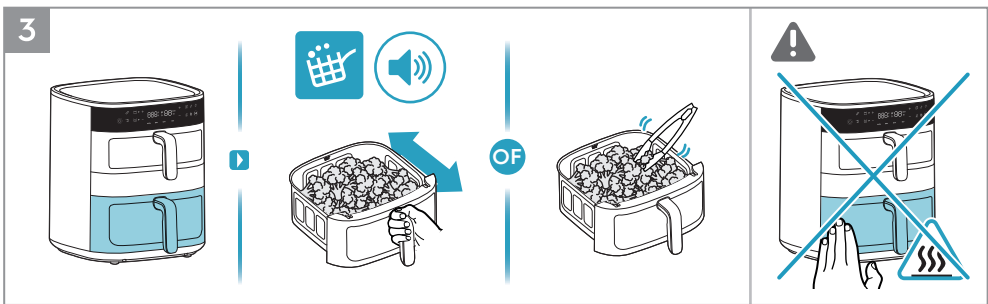

3. Wanneer het pictogram "Schudherinnering" oplicht en er een geluidssignaal klinkt tijdens het bereiden, gebruik dan hittebestendige hulpmiddelen om het eten eenmaal om te draaien of schud het eten voorzichtig in de frituurmand.

⚠ **OPGELET:** Schud de frituurmand niet te hard om te voorkomen dat er eten uit spat en brandwonden veroorzaakt

⚠ **OPGELET:** Wees voorzichtig met hete oppervlakken wanneer het apparaat in gebruik is.

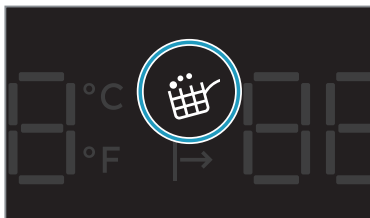

Schudherinnering

De "Schudherinnering" wordt geactiveerd tijdens de Air Fry-functie en de vooraf ingestelde recepten, zoals groenten, vis, kippenpoten en biefstuk.

Op het moment dat uw eten moet worden geschud of omgedraaid, gaat het pictogram "Schudherinnering" branden en knippert het gedurende één minuut, terwijl er drie keer een pieptoon klinkt.

De "Schudherinnering" is niet verplicht, dus het kookproces gaat gewoon door, zelfs als het eten niet wordt omgedraaid of geschud.



4. Aan het einde van de bereidingstijd geeft het apparaat een piepsignaal. Verwijder de mand voorzichtig en plaats deze op een hittebestendig oppervlak. Haal de stekker na gebruik uit het stopcontact

⚠ **OPGELET:** Er kan hete stoom uit de mand komen wanneer deze halverwege of aan het einde van het kookproces wordt geopend. Zorg ervoor dat uw gezicht, armen en handen uit de buurt van de stoom blijven wanneer u het opent

Gebruiksaanwijzing - Bovenste + onderstemand

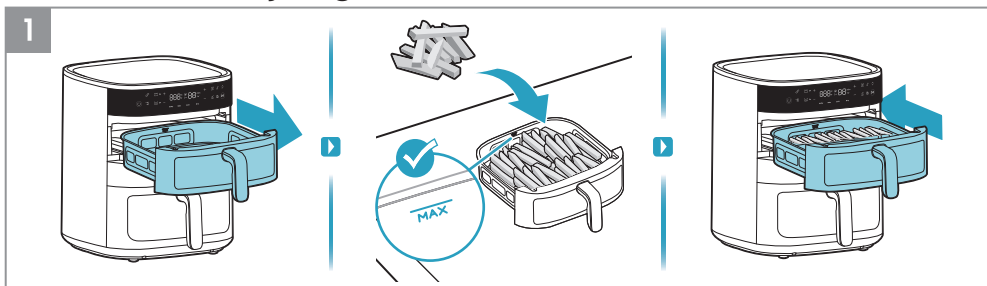

1. Trek eerst de bovenste mand eruit en doe het eten in de mand, bijvoorbeeld frietjes.

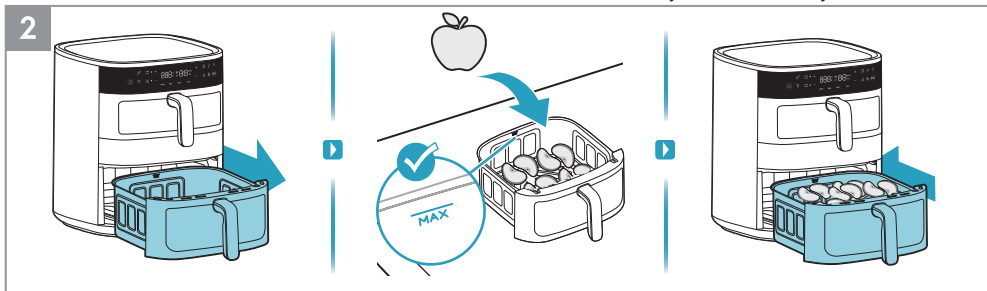

2. Trek vervolgens de onderste mand eruit en doe het eten in de mand, bijvoorbeeld appelschijfjes.



3. Druk de Aan/uit-knop. Selecteer eerst de bovenste mand. Selecteer vervolgens de gewenste bereidingswijze, bijvoorbeeld de Air Fry-functie. Pas de tijd en temperatuur aan naar uw smaak of selecteer een van de vooraf ingestelde recepten, bijvoorbeeld Groenten. Druk als laatste op de knop AfspeLEN/Pauzeren.



4. Selecteer vervolgens de onderste mand. Selecteer vervolgens de gewenste bereidingswijze, bijvoorbeeld de Droogfunctie. Stel de tijd en temperatuur naar wens in. Druk als laatste op de knop Afspelen/Pauzeren.

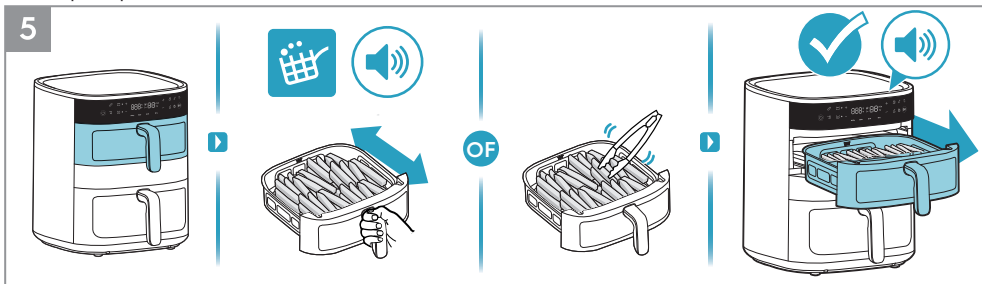

5. Wanneer het pictogram "Schudherinnering" oplicht en er een geluidssignaal klinkt tijdens het bereiden, gebruik dan hittebestendige hulpmiddelen om het eten eenmaal om te draaien of schud het eten voorzichtig in de frituurmand. Aan het einde van de bereidingstijd van de bovenste mand geeft het apparaat een piepsignaal.

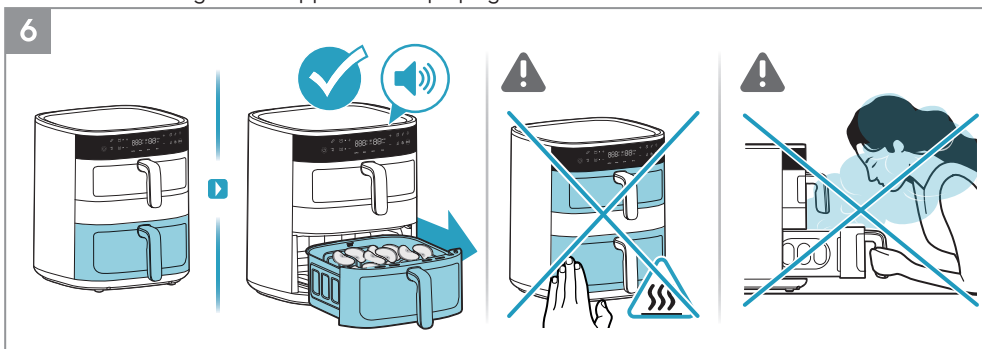

6. Aan het einde van de bereidingstijd van de onderste mand geeft het apparaat een piepsignaal.

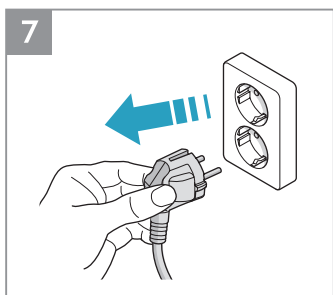

7. Haal de stekker na gebruik uit het stopcontact.

EN
BG
CZ
DE
DK
EE
FI
FR
GR
HR
HU
IT
LT
LV
NO
NL
PL
PT
RO
RU
SE
SI
SK
SR
TR
UA
ES
GE
AL

Gebruiksaanwijzing - Koppelfunctie

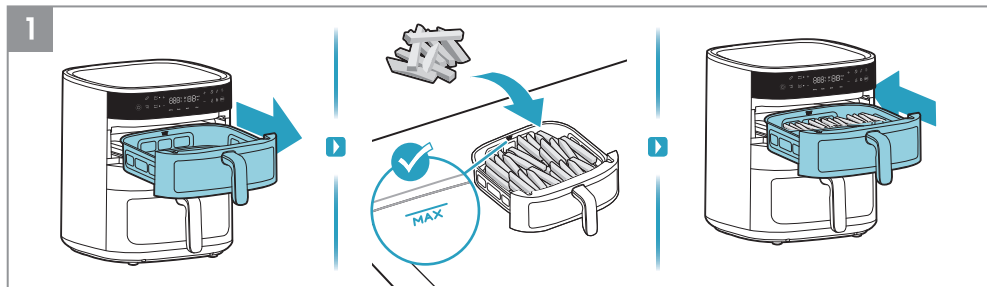

1. Trek eerst de bovenste mand eruit en doe het eten in de mand, bijvoorbeeld frietjes.

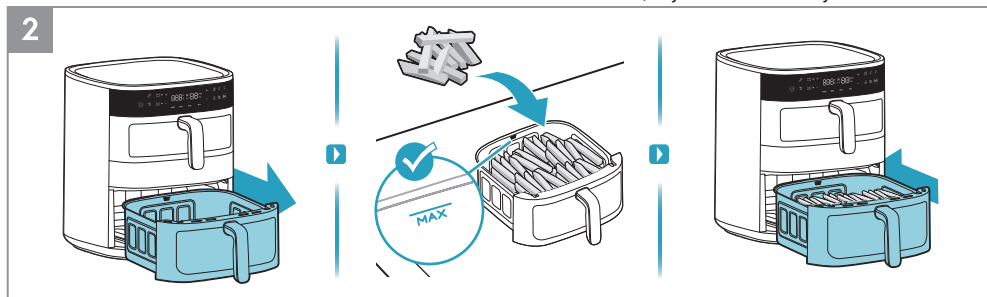

2. Trek vervolgens de onderste mand eruit en doe het eten in de mand, bijvoorbeeld patat.



3. Druk de Aan/uit-knop. Selecteer eerst de koppelfunctie. Selecteer vervolgens de gewenste bereidingswijze, bijvoorbeeld de Air Fry-functie. Pas de tijd en temperatuur aan naar uw smaak of selecteer een van de vooraf ingestelde recepten. Druk als laatste op de knop Afspelen/Pauzeren.

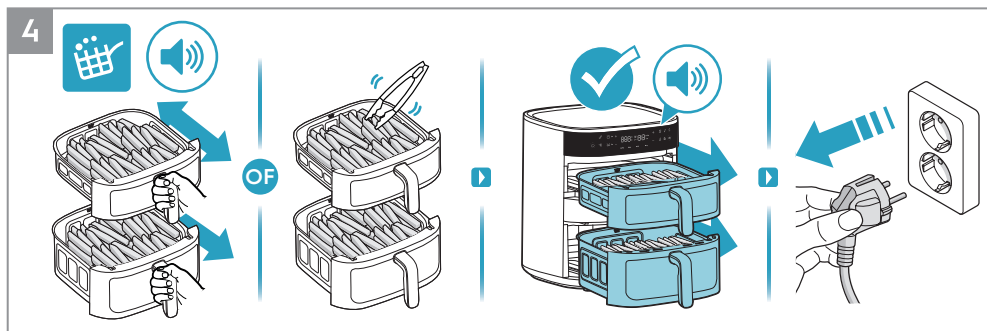

4. Wanneer het pictogram "Schudherinnering" oplicht en er een geluidssignaal klinkt tijdens het bereiden, gebruik dan hittebestendige hulpmiddelen om het eten eenmaal om te draaien of schud het eten voorzichtig in de frituurmand. Aan het einde van de bereidingstijd geeft het apparaat een piepsignaal. Haal de stekker na gebruik uit het stopcontact.

Gebruiksaanwijzing - Synchronisatiefunctie beëindigen

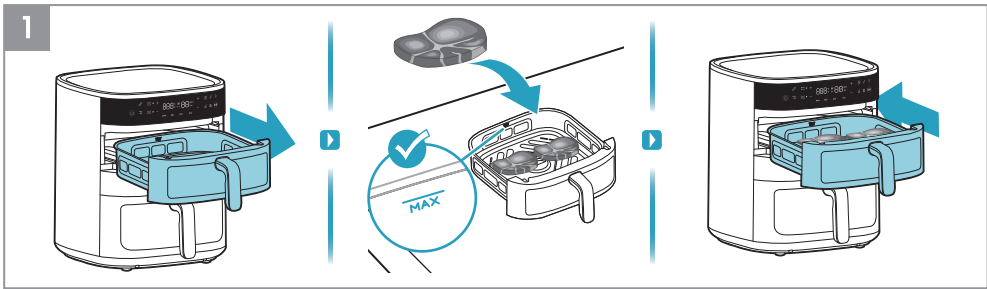

1. Trek eerst de bovenste mand eruit en doe het eten in de mand, bijvoorbeeld steak.

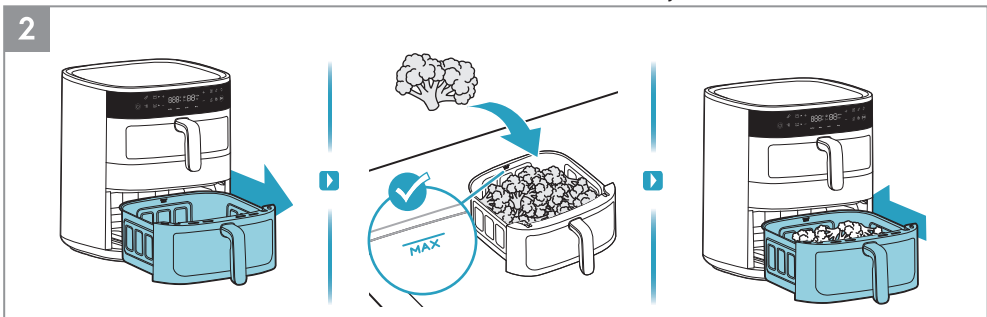

2. Trek vervolgens de onderste mand eruit en doe het eten in de mand, bijvoorbeeld broccoli.



3. Druk de Aan/uit-knop. Selecteer de Synchronisatiefunctie beëindigen. Selecteer eerst de bovenste mand en vervolgens de gewenste bereidingswijze, bijvoorbeeld de Air Fry-functie. Pas de tijd en temperatuur aan naar uw smaak of selecteer een van de vooraf ingestelde recepten, bijvoorbeeld steak.

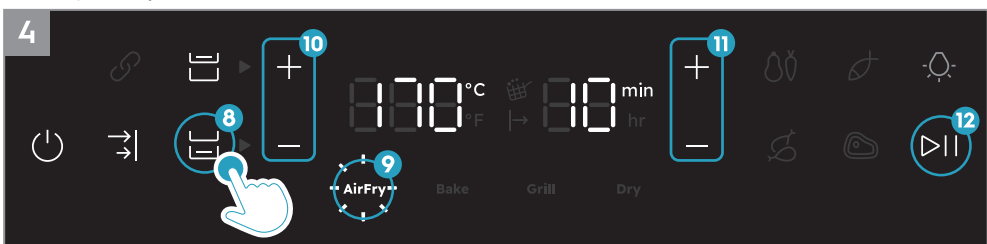

4. Selecteer vervolgens de onderste mand en kies de gewenste bereidingswijze, bijvoorbeeld de Air Fry-functie. Pas de tijd en temperatuur aan naar uw smaak of selecteer een van de vooraf ingestelde recepten. Druk als laatste op de knop Afspelen/Pauzeren.

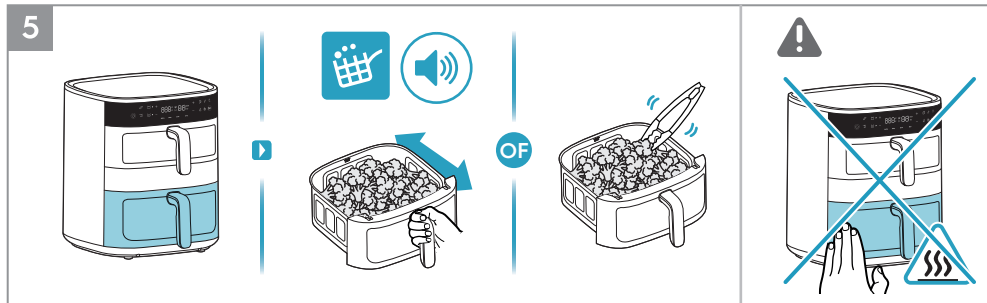

5. Ten eerste wordt de onderste mand met een langere insteltijd voorrang gegeven bij het koken. Wanneer het pictogram “Schudherinnering” oplicht en er een geluidssignaal klinkt tijdens het bereiden, gebruik dan hittebestendige hulpmiddelen om het eten eenmaal om te draaien of schud het eten voorzichtig in de frituurmand.

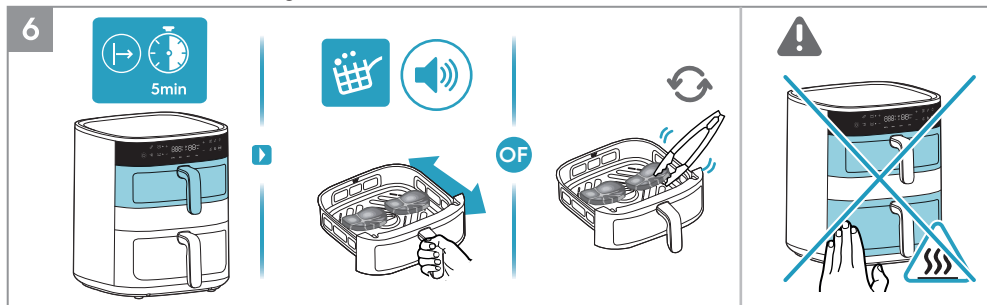

6. Ten tweede begint de bovenste mand met een kortere insteltijd met koken. Wanneer het pictogram “Schudherinnering” oplicht en er een geluidssignaal klinkt tijdens het bereiden, gebruik dan hittebestendige hulpmiddelen om het eten eenmaal om te draaien of schud het eten voorzichtig in de frituurmand.

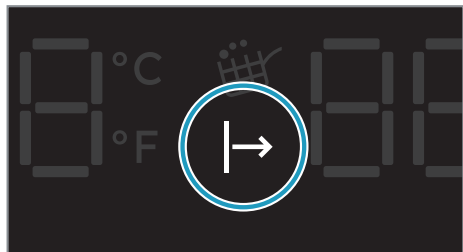

Wachten op kookindicator

Wanneer de functie “Synchronisatiefunctie beëindigen” is geactiveerd, wacht de mand met de kortere bereidingstijd totdat de mand met de langere bereidingstijd een tijdje heeft gekookt, zodat beide manden tegelijkertijd klaar zijn met koken. Tijdens deze fase blijft de “Wachten op kookindicator” branden totdat het koken begint.

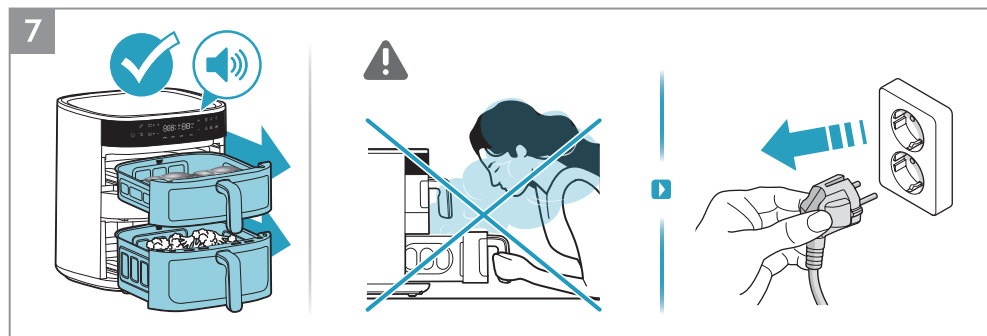

7. Aan het einde van de bereidingstijd geeft het apparaat een piepsignaal. Haal de stekker na gebruik uit het stopcontact.

Reiniging

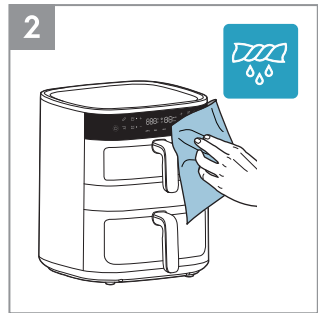
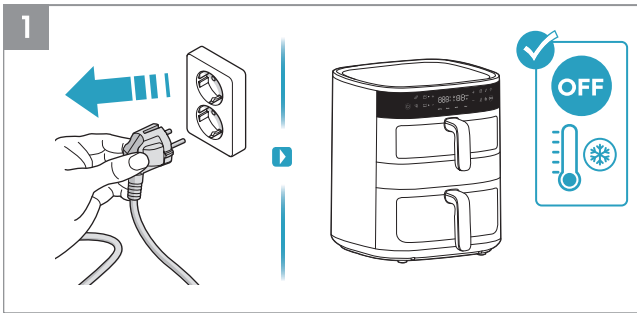

1. Haal altijd de stekker uit het stopcontact en wacht tot het apparaat is afgekoeld voordat u het schoonmaakt
2. Veeg de buitenkant van het apparaat af met een zachte doek.

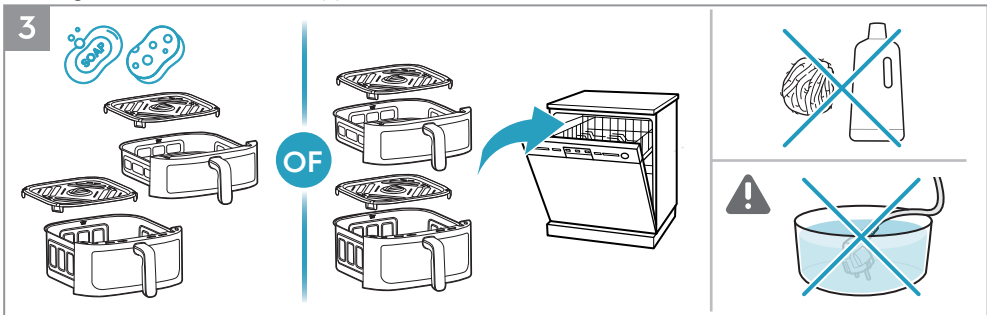

3. Reinig de pan en het rooster met warm water en afwasmiddel, of plaats ze in de vaatwasser.

⚠OPMERKING: Gebruik geen schurende reinigingsmiddelen of metalen gereedschap om de antiaanbaklaag te beschermen.

OPGELET: Dompel het product, het snoer of de stekker nooit onder in water of een andere vloeistof.

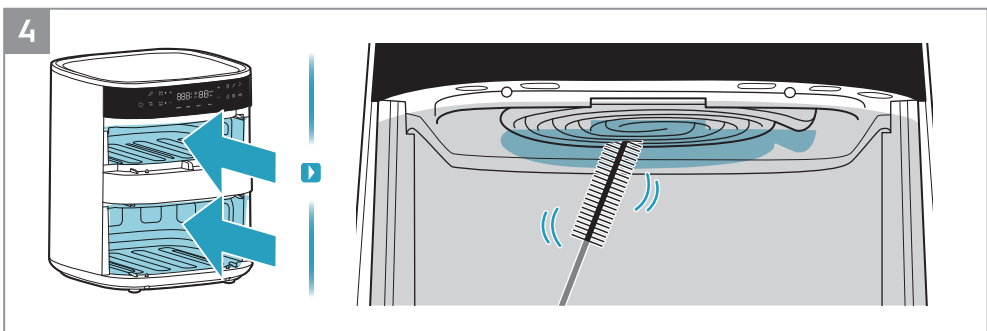











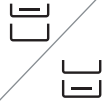







































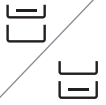











4. Reinig het verwarmingselement met een reinigingsborstel.

OPMERKING: Zorg dat het apparaat volledig is afgekoeld voordat u het verwarmingselement schoonmaakt

EN
BG
CZ
DE
DK
EE
FI
FR
GR
HR
HU
IT
LT
LV
NO
NL
PL
PT
RO
RU
SE
SI
SK
SR
TR
UA
ES
GE
AL

Kookgids

								
AirFry	7mm/10mm 	4l 	400g	180°C	18min			
		7l 	400g	180°C	18min			
AirFry		4l 	400g	170°C	8min			
		7l 	400g	170°C	10min			
AirFry		4l 	400g/2stuk	140°C	15min			
		7l 	400g/2stuk	140°C	15min			
AirFry		4l 	1000g/8stuk	180°C	28min			
		7l 	1000g/8stuk	180°C	28min			
AirFry		4l 	400g/2stuk	200°C	10min			
		7l 	400g/2stuk	200°C	10min			
AirFry		4l 	220g/15 cm	160°C	12min			
		7l 	220g/15 cm	160°C	14min			

							
AirFry		 4l	1200g	180°C	55min		
AirFry		 7l	400g/9stuks	160°C	20min		
Grill		 4l	180g/4stuks	180°C	8min		
		 7l	180g/4stuks	180°C	9min		
Dry		 4l	180g	80°C	3h		
		 7l	180g	80°C	3h		
Dry		 4l	200g	80°C	3h		
		 7l	200g	80°C	3h		

- EN
- BG
- CZ
- DE
- DK
- EE
- FI
- FR
- GR
- HR
- HU
- IT
- LT
- LV
- NO
- NL**
- PL
- PT
- RO
- RU
- SE
- SI
- SK
- SR
- TR
- UA
- ES
- GE
- AL

Wat te doen als...

Probleem	Controleer of...
U het apparaat niet kunt activeren of bedienen.	<ul style="list-style-type: none"> • Het apparaat is correct aangesloten op een stroombron. • De manden staan in de juiste positie. Zorg ervoor dat ze volledig in het apparaat zijn gedrukt om de stroomtoevoer mogelijk te maken. • De kooktijd is ingesteld.
U de mand niet in het apparaat kunt schuiven.	<ul style="list-style-type: none"> • De mand is boven zijn maximale capaciteit gevuld. • De mand is correct geplaatst. Het moet vastklikken wanneer u het in de eenheid plaatst. • Er ligt een voorwerp onder de mand dat verhindert dat deze goed kan worden gesloten.
Er witte rook uit het apparaat komt.	<ul style="list-style-type: none"> • Het eten dat u bereidt is te vet. • De mand, het rooster en het verwarmingselement zijn schoon.
Het display E1 weergeeft	<ul style="list-style-type: none"> • Open stroomkring in de bovenste mand.
Het display E2 weergeeft	<ul style="list-style-type: none"> • Kortsluiting in de bovenste mand.
Het display E3 weergeeft	<ul style="list-style-type: none"> • Open stroomkring in de onderste mand.
Het display E4 weergeeft	<ul style="list-style-type: none"> • Kortsluiting in de onderste mand.
Het display E5 weergeeft	<ul style="list-style-type: none"> • Communicatiestoring van de besturingsprintplaat
Het display E6 weergeeft	<ul style="list-style-type: none"> • Communicatiestoring van de voedingsprintplaat

* Als er foutcodes op het display worden weergegeven, moet het apparaat door een Servicecentrum worden gerepareerd.

Technische gegevens

Product	Air Fryer
Model	EAFD11B
Spanning (V~)	220 V - 240 V
Vermogen (W)	2700 W
Frequentie (Hz)	50 ~ 60 Hz
Capaciteit	4 l + 7 l



Instrukcja obsługi

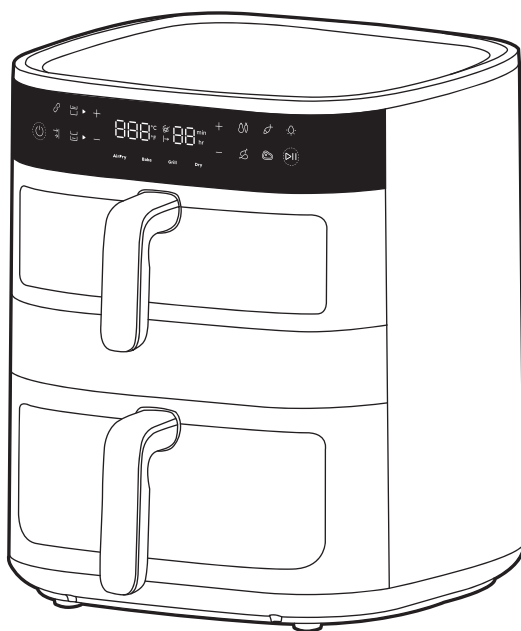

800 Air Fryer Dual

EN
BG
CZ
DE
DK
EE
FI
FR
GR
HR
HU
IT
LT
LV
NO
NL
PL
PT
RO
RU
SE
SI
SK
SR
TR
UA
ES
GE
AL

Przegląd ogólny

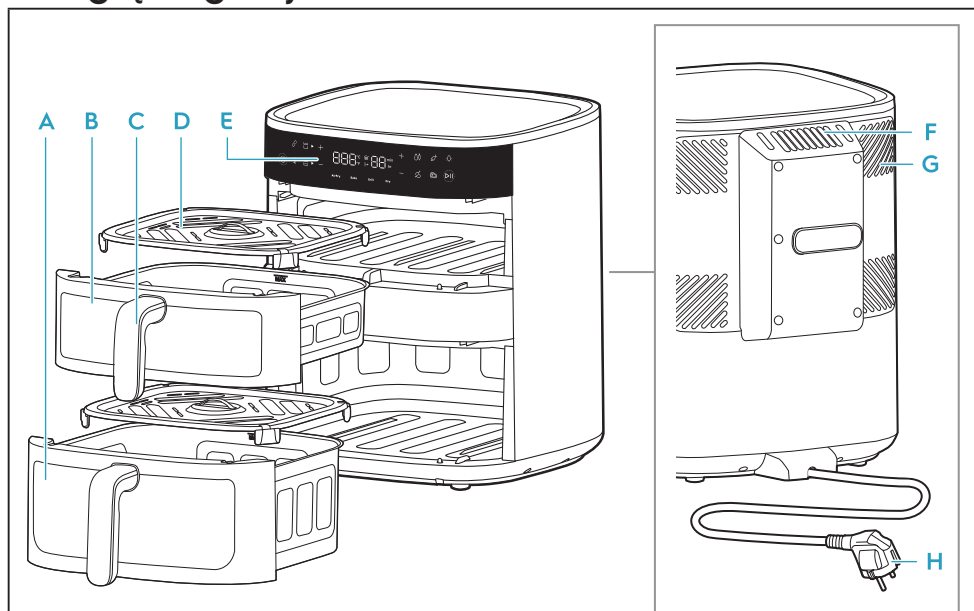

- A** Dolny kosz (7L) **C** Uchwyt kosza **E** Panel sterowania **G** System chłodzenia
B Górny kosz (4L) **D** Kratka **F** Wylot powietrza **H** Przewód zasilający

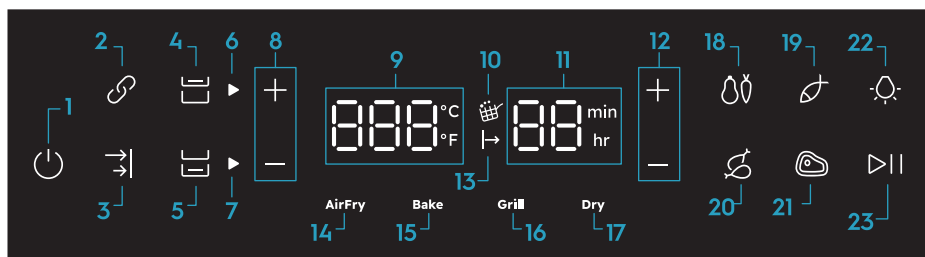

- | | | | |
|---------------------------------------|------------------------------------|--|-----------------------------|
| 1. Wł./Wył. | 7. Wskaźnik dolnego kosza | 11. Wskaźnik czasu (AirFry: 1-99 min, Suszenie: 1-5 godz.) | 17. Funkcja suszenia |
| 2. Funkcja połączenia koszy | 8. Regulacja temperatury | 12. Regulacja czasu | 18. Warzywa |
| 3. Funkcja synchronizacji zakończenia | 9. Wskaźnik temperatury (40-200°C) | 13. Oczekiwanie na rozpoczęcie gotowania | 19. Ryba |
| 4. Sterowanie górnym koszem | 10. Przypomnienie o potrząśnięciu | 14. Funkcja AirFry | 20. Kurczak |
| 5. Sterowanie dolnym koszem | | 15. Funkcja pieczenia | 21. Stek |
| 6. Wskaźnik górnego kosza | | 16. Funkcja grillowania | 22. Sterowanie oświetleniem |
| | | | 23. Start/Pauza |

Przed pierwszym użyciem

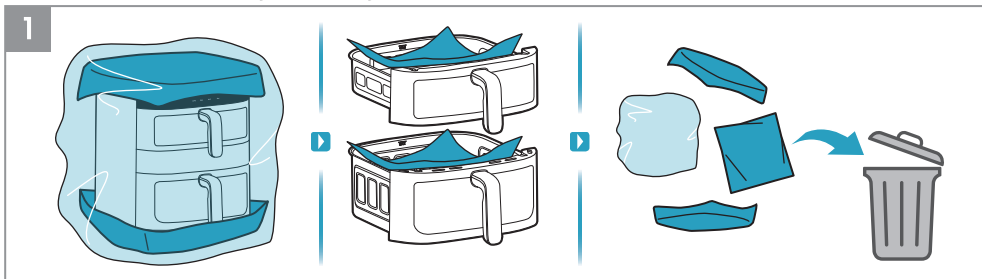

1. Należy usunąć wszystkie materiały opakowaniowe i zabezpieczające.

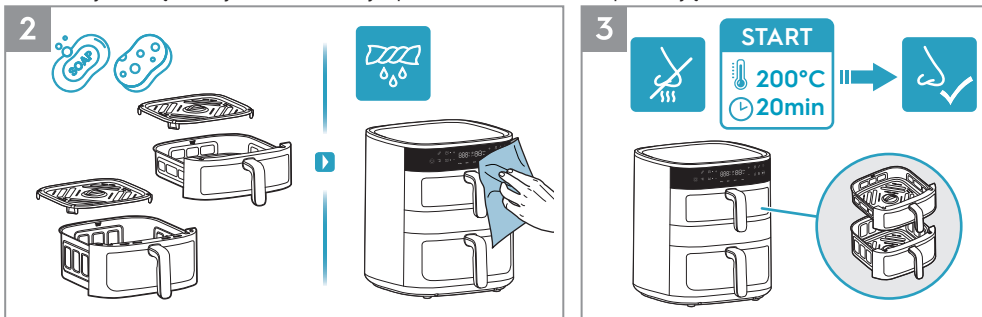

2. Należy umyć kosze i kratkę w ciepłej wodzie z dodatkiem płynu do mycia naczyń. Należy przetrzeć wnętrze i zewnętrzną część urządzenia miękką ściereczką.

3. To normalne, że nowe urządzenie może wydzielać zapach podczas pierwszych kilku użycy. Aby usunąć zapach nowego urządzenia, przed pierwszym użyciem należy uruchomić pustą frytkownicę beztłuszczową w temperaturze 200°C na 20 minut.

! Informacje dotyczące bezpieczeństwa

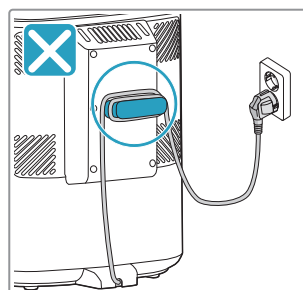
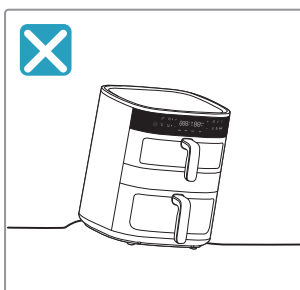
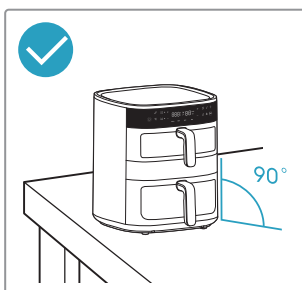
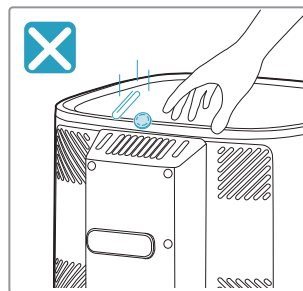
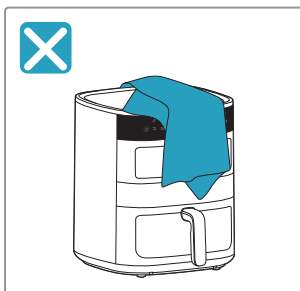
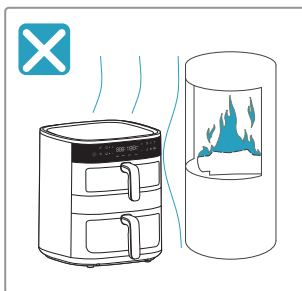





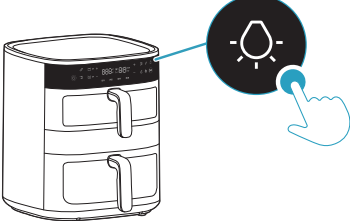
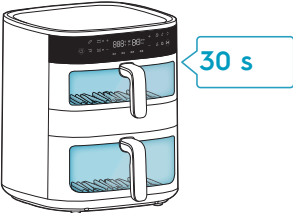
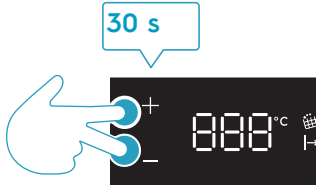
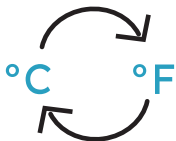



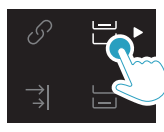





EN
BG
CZ
DE
DK
EE
FI
FR
GR
HR
HU
IT
LT
LV
NO
NL
PL
PT
RO
RU
SE
SI
SK
SR
TR
UA
ES
GE
AL







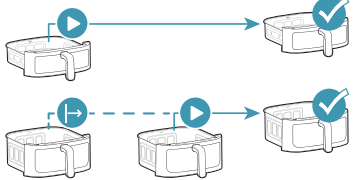







Sterowanie oświetleniem i zmiana jednostek temperatury

 <p>Sterowanie oświetleniem</p>		
<p>°C/°F</p> <p>Zmiana jednostek temperatury</p>		

Wybór kosza

	 <p>4L</p>	 <p>7L</p>	
 <p>Górny kosz</p>			
 <p>Dolny kosz</p>			
 <p>Funkcja połączenia koszy</p>			
 <p>Funkcja synchronizacji zakończenia</p>			

Zaprogramowane funkcje

					
Air Fry	180°C	15min	60-200°C	1-99min	
	170°C	10min	60-200°C	1-99min	
	140°C	15min	60-200°C	1-99min	
	180°C	30min	60-200°C	1-99min	
	200°C	10min	60-200°C	1-99min	
Bake	170°C	15min	60-200°C	1-99min	
Grill	200°C	5min	60-200°C	1-99min	
Dry	80°C	5godz.	40-80°C	1-5godz.	

Przed rozpoczęciem gotowania

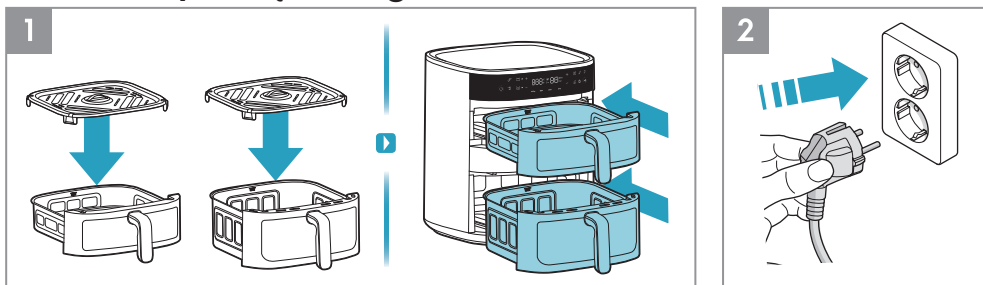

1. Przed każdym gotowaniem należy umieścić kratkę w koszu (silikonowe, żaroodporne stopki kratki mogą pozostać na miejscu), a następnie całkowicie wsunąć kosz do urządzenia.
2. Włożyć wtyczkę przewodu zasilającego do gniazdka.

Sposób użycia – pojedynczy kosz

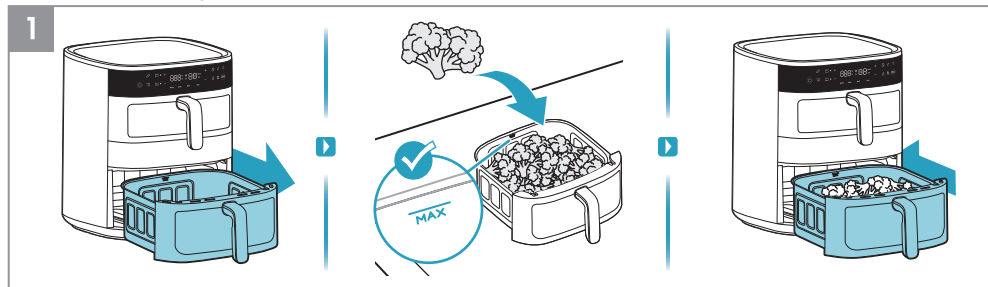

1. Wysunąć jeden kosz, postawić go na stabilnej powierzchni, a następnie włożyć do niego żywność, nie przekraczając oznaczenia maksymalnego poziomu "MAX.". Następnie całkowicie wsunąć kosz z żywnością do urządzenia.



2. Naciśnąć przyciski Wł./Wył. Najpierw wybrać kosz z żywnością. Następnie wybrać żądaną metodę przygotowywania, na przykład funkcję frytkownicy beztłuszczowej. Dostosować czas i temperaturę według własnych preferencji lub wybrać jeden z zaprogramowanych przepisów, na przykład Warzywa. Na koniec naciśnąć przycisk Start/Pauza.

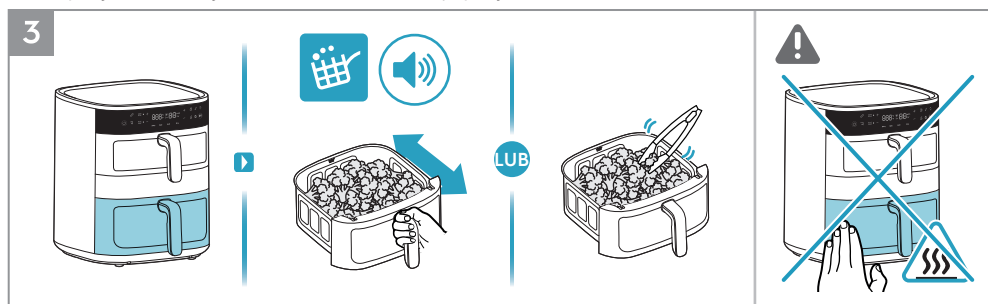

3. Gdy podczas procesu gotowania zaświeci się i wyda sygnał dźwiękowy ikona "Przypomnienie o potrząśnięciu", należy użyć narzędzi odpornych na wysoką temperaturę, aby jednokrotnie obrócić żywność lub ostrożnie lekko potrząsnąć koszem do smażenia.

⚠ **UWAGA:** Nie potrząsać koszem do smażenia gwałtownie, aby uniknąć rozpryskiwania żywności i ryzyka poparzenia.

⚠ **UWAGA:** Podczas pracy urządzenia należy zachować ostrożność w pobliżu gorących powierzchni.

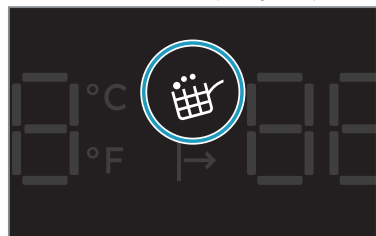

Przypomnienie o potrząśnięciu

"Przypomnienie o potrząśnięciu" jest aktywowane podczas funkcji frytkownicy beztłuszczowej oraz w zaprogramowanych przepisach, takich jak warzywa, ryba, udka z kurczaka i stek.

Gdy nadejdzie czas potrząśnięcia lub obrócenia żywności, ikona "Przypomnienie o potrząśnięciu" zaświeci się i będzie migać przez jedną minutę, a sygnał dźwiękowy powtórzy się trzykrotnie.

"Przypomnienie o potrząśnięciu" nie jest obowiązkowe, dlatego gotowanie będzie kontynuowane jak zwykle, nawet jeśli żywność nie zostanie obrócona ani potrząśnięta.



4. Po zakończeniu czasu gotowania urządzenie wyemituje sygnał dźwiękowy. Ostrożnie wyjąć kosz i postawić go na powierzchni odpornej na wysoką temperaturę. Po zakończeniu użytkowania odłączyć urządzenie od zasilania.

⚠ **UWAGA:** Gorąca para może wydostawać się z kosza podczas jego otwierania w trakcie lub po zakończeniu gotowania. Podczas otwierania należy upewnić się, że twarz, ramiona i dłonie znajdują się z dala od pary.

Sposób użycia – górny + dolny kosz

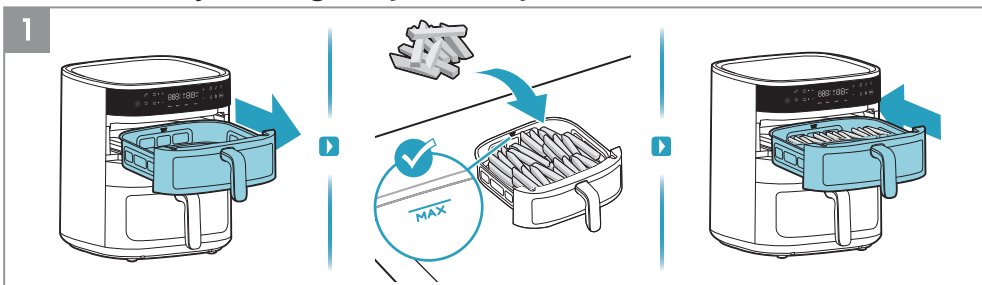

1. Najpierw wysunąć górny kosz i włożyć do niego żywność, na przykład frytki.

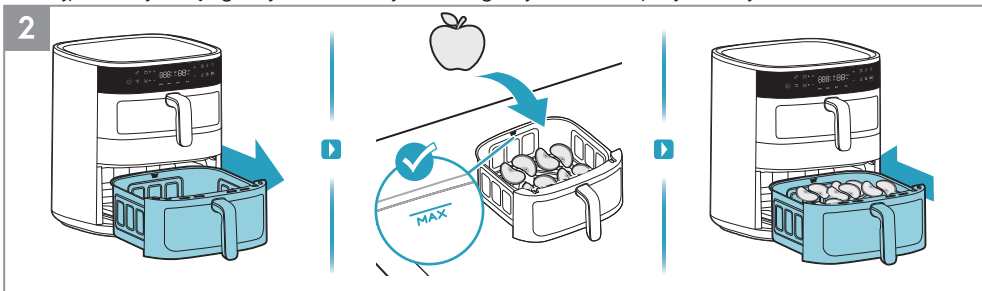

2. Następnie wysunąć dolny kosz i włożyć do niego żywność, na przykład plasterki jabłek.



3. Naciśnąć przycisk Wł./Wył. Najpierw wybrać górny kosz. Następnie wybrać żądaną metodę przygotowywania, na przykład funkcję Air Fry. Dostosować czas i temperaturę według własnych preferencji lub wybrać jeden z zaprogramowanych przepisów, na przykład Warzywa. Na koniec naciśnąć przycisk Start/Pauza.



4. Następnie wybrać dolny kosz. Następnie wybrać żądaną metodę przygotowywania, na przykład funkcję suszenia. Dostosować czas i temperaturę według własnych preferencji. Na koniec nacisnąć przycisk Start/Pauza.

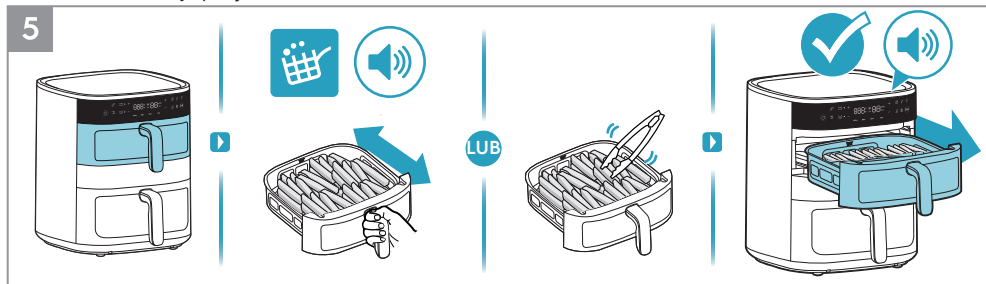

5. Gdy podczas procesu gotowania zaświeci się i wyda sygnał dźwiękowy ikona "Przypomnienie o potrząśnięciu", należy użyć narzędzi odpornych na wysoką temperaturę, aby jednokrotnie obrócić żywność lub ostrożnie lekko potrząsnąć koszem do smażenia. Po zakończeniu czasu gotowania górnego kosza urządzenie wyemituje sygnał dźwiękowy.

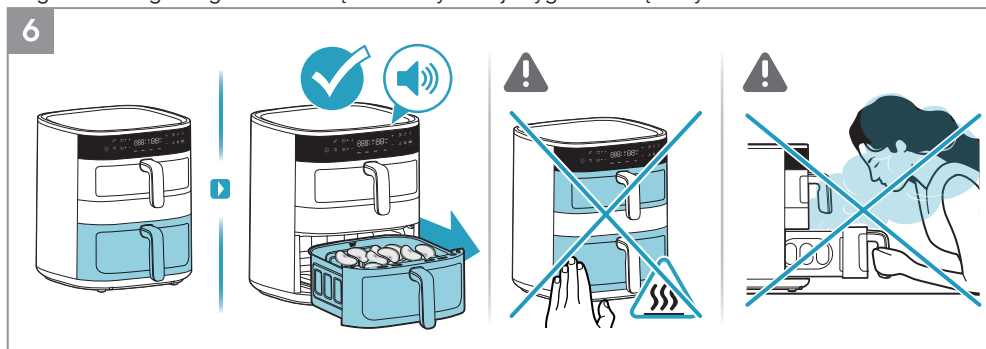

6. Po zakończeniu czasu gotowania dolnego kosza urządzenie wyemituje sygnał dźwiękowy.

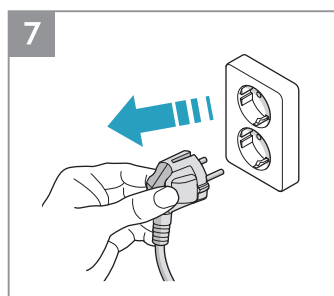

7. Po zakończeniu użytkowania odłączyć urządzenie od zasilania.

Sposób użycia – funkcja połączenia koszy

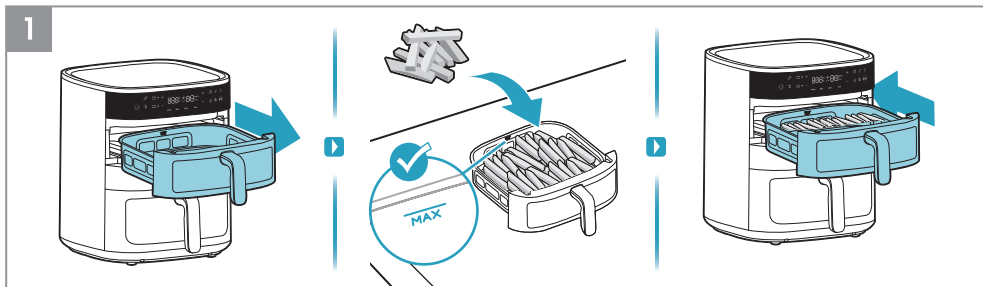

1. Najpierw wysunąć górny kosz i włożyć do niego żywność, na przykład frytki.

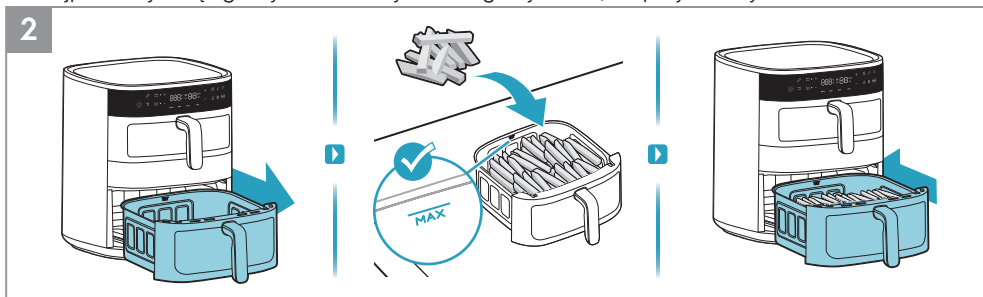

2. Następnie wysunąć dolny kosz i włożyć do niego żywność, na przykład frytki.

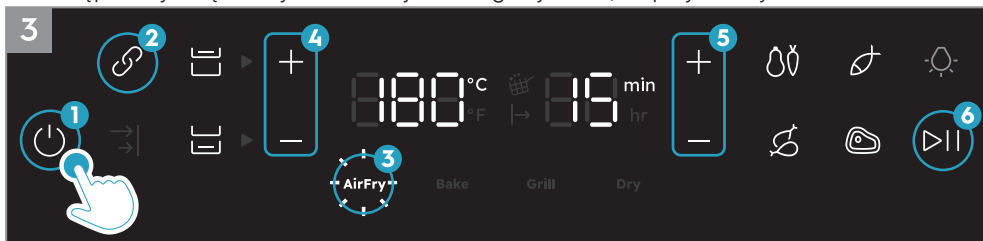

3. Nacisnąć przycisk Wł./Wył. Najpierw wybrać funkcję połączenia koszy. Następnie wybrać żądaną metodę przygotowywania, na przykład funkcję Air Fry. Dostosować czas i temperaturę według własnych preferencji lub wybrać jeden z zaprogramowanych przepisów. Na koniec nacisnąć przycisk Start/Pauza.

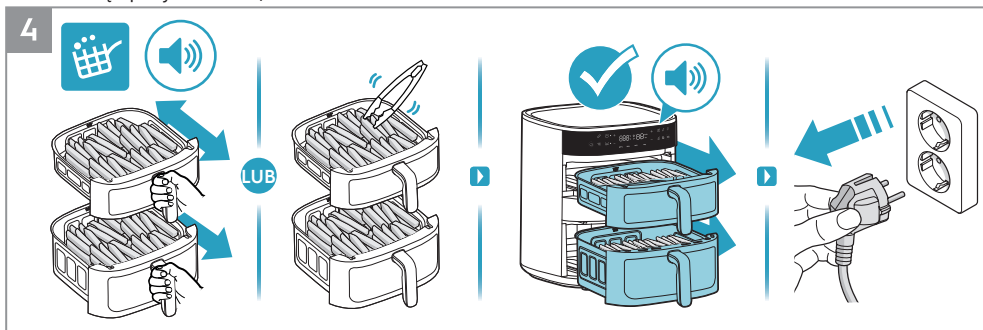

4. Gdy podczas procesu gotowania zaświeci się i wyda sygnał dźwiękowy ikona "Przypomnienie o potrząśnięciu", należy użyć narzędzi odpornych na wysoką temperaturę, aby jednokrotnie obrócić żywność lub ostrożnie lekko potrząsnąć koszem do smażenia. Po zakończeniu czasu gotowania urządzenie wyemituje sygnał dźwiękowy. Po zakończeniu użytkowania odłączyć urządzenie od zasilania.

Sposób użycia – funkcja synchronizacji zakończenia

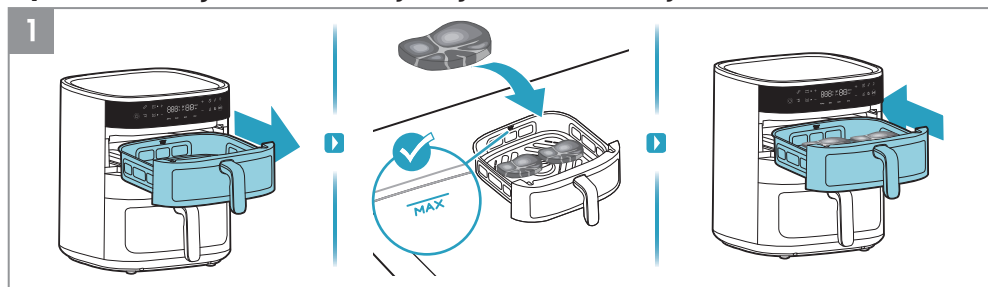

1. Najpierw wysunąć górny kosz i włożyć do niego żywność, na przykład stek.

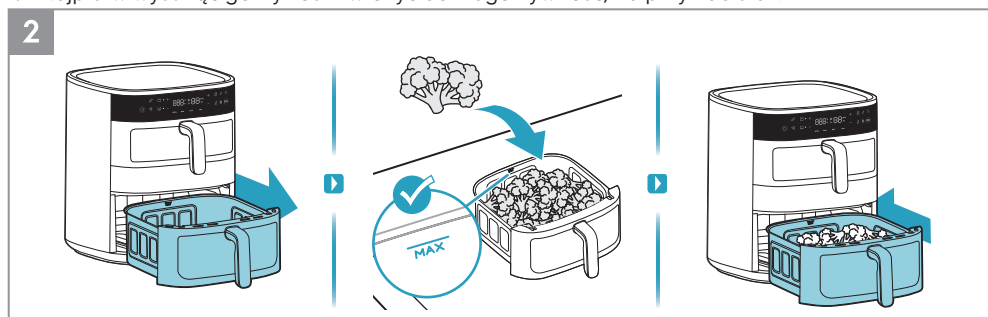

2. Następnie wysunąć dolny kosz i włożyć do niego żywność, na przykład brokuły.



3. Naciśnięć przycisk Wł./Wył. Wybrać funkcję synchronizacji zakończenia. Najpierw wybrać górny kosz, a następnie wybrać żądaną metodę przygotowywania, na przykład funkcję frytkownicy beztłuszczowej. Dostosować czas i temperaturę według własnych preferencji lub wybrać jeden z zaprogramowanych przepisów, na przykład Stek.

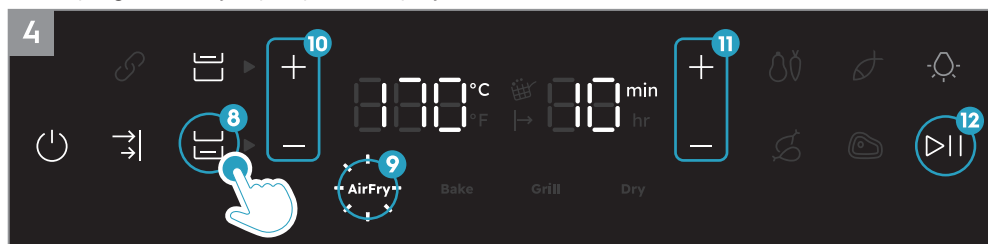

4. Następnie wybrać dolny kosz i wybrać żądaną metodę przygotowywania, na przykład funkcję frytkownicy beztłuszczowej. Dostosować czas i temperaturę według własnych preferencji lub wybrać jeden z zaprogramowanych przepisów. Na koniec naciśnięć przycisk Start/Pauza.

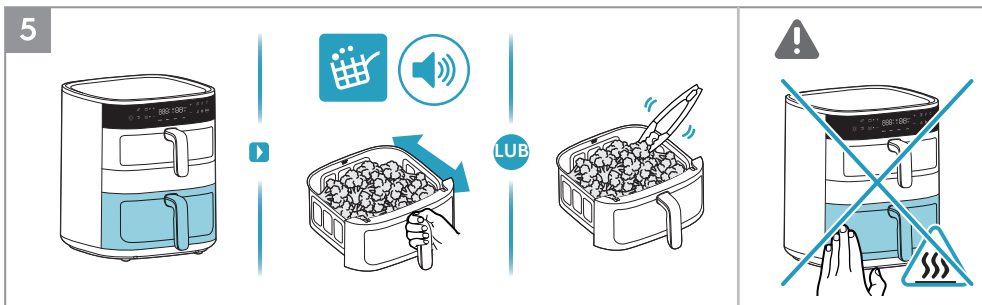

5. Najpierw rozpocznie się gotowanie w dolnym koszu z dłuższym ustawionym czasem. Gdy podczas procesu gotowania zaświeci się i wyda sygnał dźwiękowy ikona "Przypomnienie o potrząśnięciu", należy użyć narzędzi odpornych na wysoką temperaturę, aby jednokrotnie obrócić żywność lub ostrożnie lekko potrząsnąć koszem do smażenia.

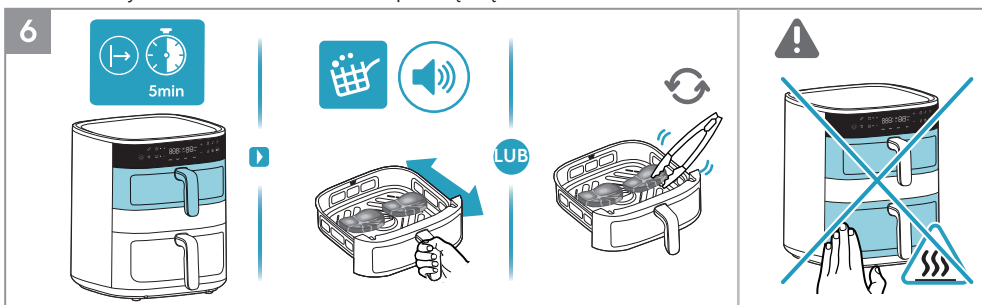

6. Następnie rozpocznie się gotowanie w górnym koszu z krótszym ustawionym czasem. Gdy podczas procesu gotowania zaświeci się i wyda sygnał dźwiękowy ikona "Przypomnienie o potrząśnięciu", należy użyć narzędzi odpornych na wysoką temperaturę, aby jednokrotnie obrócić żywność lub ostrożnie lekko potrząsnąć koszem do smażenia.

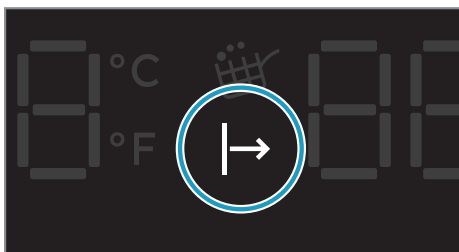

Wskaźnik oczekiwania na rozpoczęcie gotowania

Gdy "Funkcja synchronizacji zakończenia" jest aktywna, kosz z krótszym czasem gotowania będzie oczekiwał na rozpoczęcie pracy, aż kosz z dłuższym czasem gotowania będzie pracował przez pewien czas, tak aby oba kosze zakończyły gotowanie jednocześnie. W tym czasie świeci się "Wskaźnik oczekiwania na rozpoczęcie gotowania" aż do rozpoczęcia gotowania.

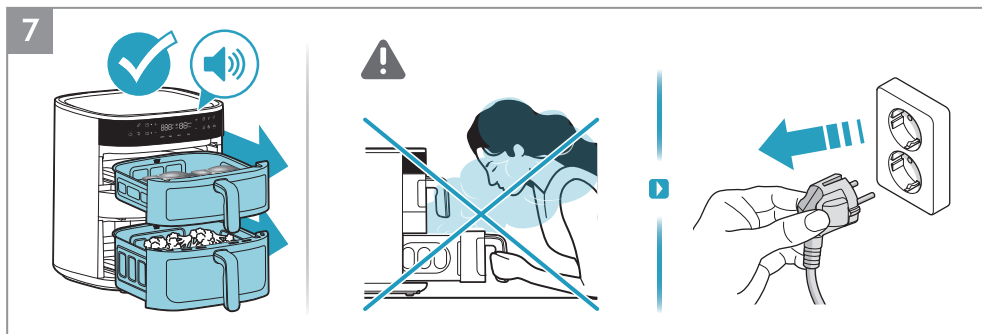

7. Po zakończeniu czasu gotowania urządzenie wyemituje sygnał dźwiękowy. Po zakończeniu użytkowania odłączyć urządzenie od zasilania.

Czyszczenie

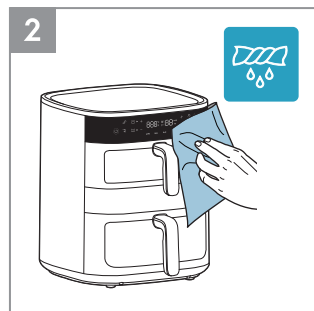
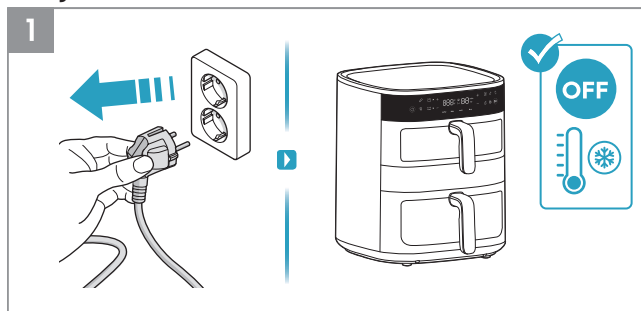

1. Przed czyszczeniem zawsze odłączyć urządzenie od zasilania i poczekać, aż całkowicie ostygnie.
2. Przetrzeć zewnętrzną powierzchnię urządzenia miękką ściereczką.

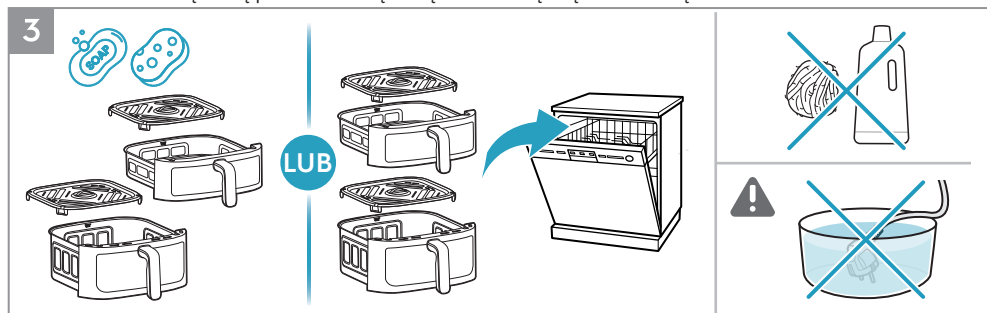

3. Umyć kosz i kratkę w ciepłej wodzie z dodatkiem płynu do mycia naczyń lub umieścić je w zmywarce.

ΔINFORMACJA: Aby chronić powłokę nieprzywierającą, należy unikać stosowania ściernych środków czyszczących oraz metalowych narzędzi.



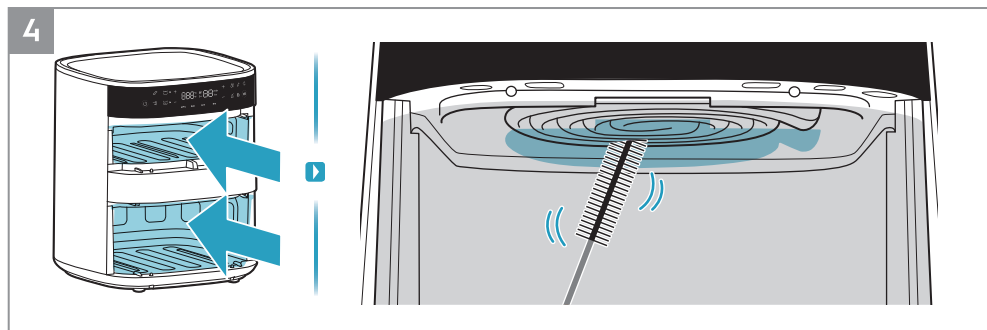









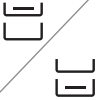

























UWAGA: Nigdy nie zanurzać urządzenia, przewodu zasilającego ani wtyczki w wodzie ani w żadnej innej cieczy.



4. Element grzejny czyścić szczotką do czyszczenia.



























INFORMACJA: Przed czyszczeniem elementu grzejnego należy upewnić się, że urządzenie całkowicie ostygło.

Przewodnik gotowania

							
AirFry	7mm/10mm 	 4L	400g	180°C	18min		
		 7L	400g	180°C	18min		
AirFry		 4L	400g	170°C	8min		
		 7L	400g	170°C	10min		
AirFry		 4L	400g/2szt.	140°C	15min		
		 7L	400g/2szt.	140°C	15min		
AirFry		 4L	1000g/8szt.	180°C	28min		
		 7L	1000g/8szt.	180°C	28min		
AirFry		 4L	400g/2szt.	200°C	10min		
		 7L	400g/2szt.	200°C	10min		
AirFry		 4L	220g/6cali	160°C	12min		
		 7L	220g/6cali	160°C	14min		

- EN
- BG
- CZ
- DE
- DK
- EE
- FI
- FR
- GR
- HR
- HU
- IT
- LT
- LV
- NO
- NL
- PL**
- PT
- RO
- RU
- SE
- SI
- SK
- SR
- TR
- UA
- ES
- GE
- AL

EN
BG
CZ
DE
DK
EE
FI
FR
GR
HR
HU
IT
LT
LV
NO
NL
PL
PT
RO
RU
SE
SI
SK
SR
TR
UA
ES
GE
AL

							
AirFry		7L 	1200g	180°C	55min		
AirFry		7L 	400g/9szt	160°C	20min		
Grill		4L 	180g/4szt	180°C	8min		
Grill		7L 	180g/4szt	180°C	9min		
Dry		4L 	180g	80°C	3godz.		
Dry		7L 	180g	80°C	3godz.		
Dry		4L 	200g	80°C	3godz.		
Dry		7L 	200g	80°C	3godz.		

Co zrobić, jeśli...

Problem	Sprawdź, czy...
Nie można uruchomić ani obsługiwać urządzenia.	<ul style="list-style-type: none"> • Urządzenie jest prawidłowo podłączone do zasilania elektrycznego. • Kosze znajdują się w prawidłowym położeniu. Upewnić się, że są całkowicie wsunięte do urządzenia, aby umożliwić doprowadzenie zasilania. • Ustawiono czas gotowania.
Nie można wsunąć kosza do urządzenia.	<ul style="list-style-type: none"> • Kosz jest napęczniony powyżej maksymalnej pojemności. • Kosz jest prawidłowo umieszczony. Po umieszczeniu w urządzeniu powinien być słyszalny klik. • Pod koszem znajduje się przedmiot, który utrudnia jego prawidłowe zamknięcie.
Z urządzenia wydobywa się biały dym.	<ul style="list-style-type: none"> • Przygotowywana żywność jest zbyt tłusta. • Kosz, kratka i element grzejny są czyste.
Na wyświetlaczu pojawia się E1	<ul style="list-style-type: none"> • Przerwa w obwodzie górnego kosza.
Na wyświetlaczu pojawia się E2	<ul style="list-style-type: none"> • Zwarcie w obwodzie górnego kosza.
Na wyświetlaczu pojawia się E3	<ul style="list-style-type: none"> • Przerwa w obwodzie dolnego kosza.
Na wyświetlaczu pojawia się E4	<ul style="list-style-type: none"> • Zwarcie w obwodzie dolnego kosza.
Na wyświetlaczu pojawia się E5	<ul style="list-style-type: none"> • Błąd komunikacji płytki sterującej PCBA.
Na wyświetlaczu pojawia się E6	<ul style="list-style-type: none"> • Błąd komunikacji płytki zasilania PCBA.

* W przypadku pojawienia się kodów błędów na wyświetlaczu urządzenie musi zostać naprawione w Autoryzowanym Centrum Serwisowym.

Dane techniczne

Produkt	Frytkownica beztłuszczowa
Model	EAFD11B
Napięcie (V~)	220 V - 240 V
Moc (W)	2700 W
Częstotliwość (Hz)	50 - 60 Hz
Pojemność	4 L + 7 L



Manual do utilizador

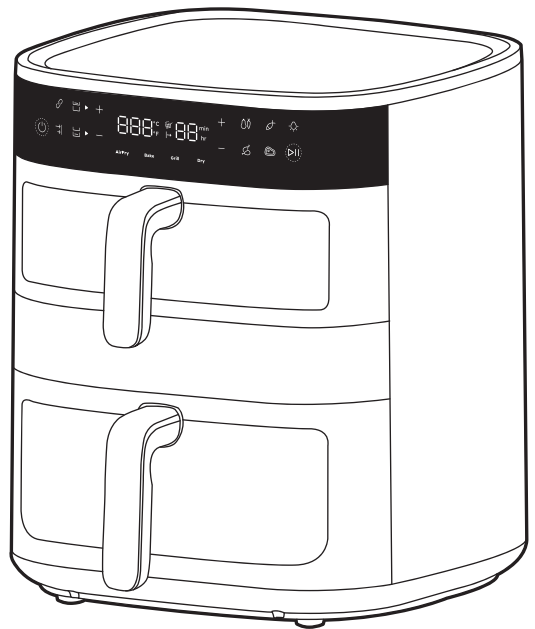

800 Air Fryer Dual

Visão geral

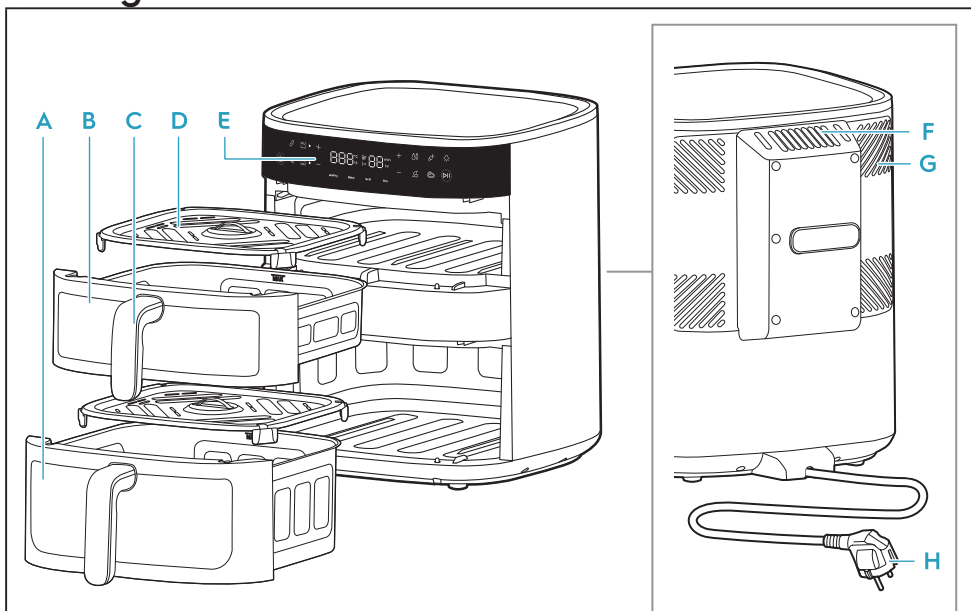

- A** Cesto inferior (7 L) **C** Pega do cesto **E** Painel de controlo **G** Sistema de arrefecimento
B Cesto superior (4 L) **D** Grelha **F** Saída de ar **H** Cabo de alimentação

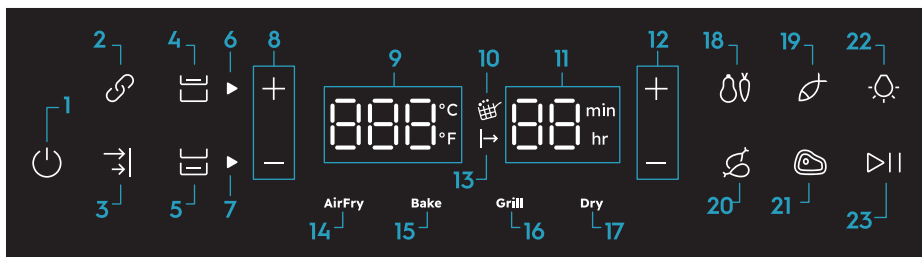

- | | | | |
|--------------------------------|---|---|-----------------------|
| 1. Ligar / desligar | 7. Indicador do cesto inferior | 11. Indicador do tempo (Fritar a ar: 1 min - 99 min, Desidratar: 1 h - 5 h) | 17. Função Desidratar |
| 2. Função Ligação | 8. Controlo da temperatura | 12. Controlo do tempo | 18. Vegetais |
| 3. Função Fim de Sincronização | 9. Indicador da temperatura (40 °C - 200 °C) | 13. Cocção em espera | 19. Peixe |
| 4. Controlo do cesto superior | 10. Aviso para Agitar | 14. Função Fritar a Ar | 20. Bife |
| 5. Controlo do cesto inferior | 11. Indicador do tempo (Fritar a ar: 1 min - 99 min, Desidratar: 1 h - 5 h) | 15. Função Cozer | 21. Steak |
| 6. Indicador do cesto superior | 12. Controlo do tempo | 16. Função Grelhar | 22. Controlo da luz |
| | 13. Cocção em espera | | 23. Iniciar / Pausar |
| | 14. Função Fritar a Ar | | |
| | 15. Função Cozer | | |
| | 16. Função Grelhar | | |

Antes da primeira utilização

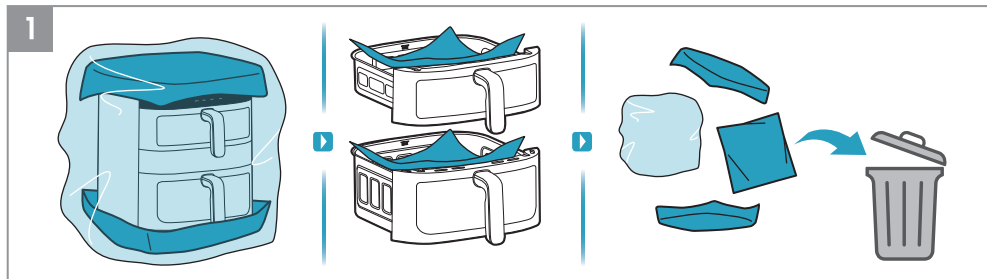

1. Remova todo material de embalagem e de proteção.

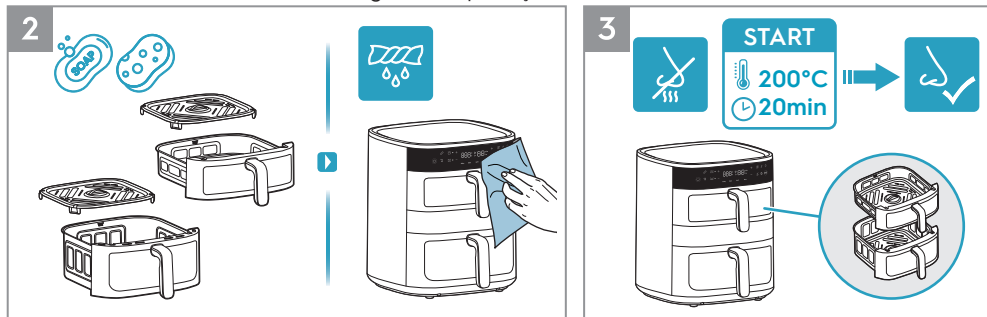

2. Limpe a frigideira e a grelha com água morna e detergente da louça. Limpe o interior e o exterior do aparelho com um pano macio.

3. É normal que uma unidade nova liberte odores nas primeiras utilizações. Para evitar esta situação, ligue a fritadeira vazia a 200 °C durante 20 minutos antes da primeira utilização.



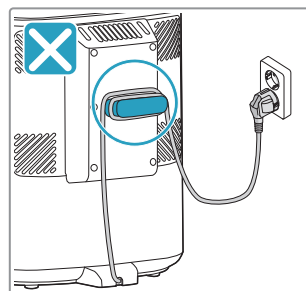
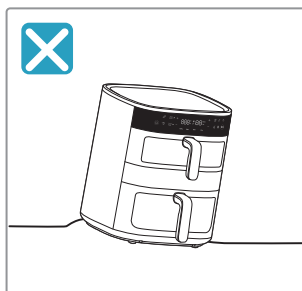
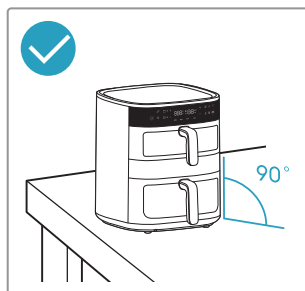
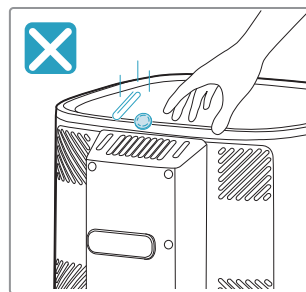
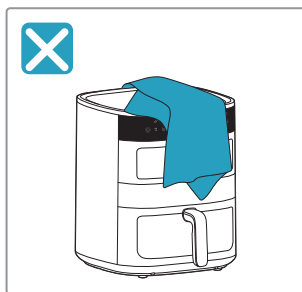
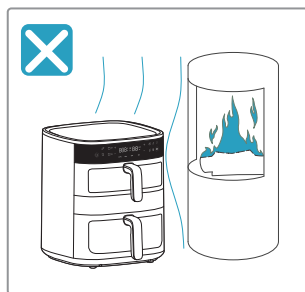



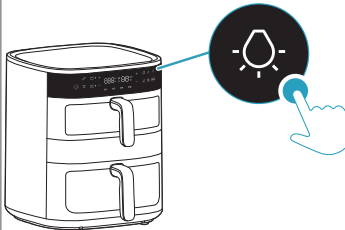
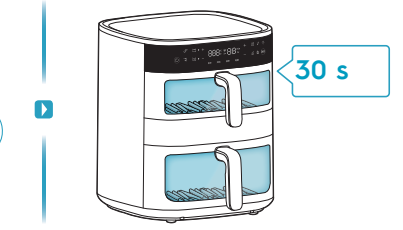
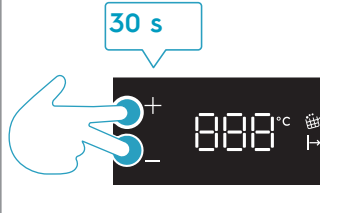
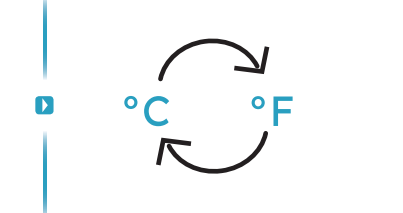







! Precauções de segurança



Controlo da luz e conversão da escala de temperatura





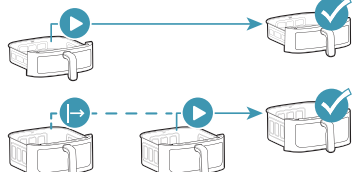





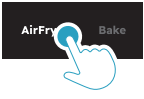



 <p>Controlo da luz</p>		
<p>°C/°F</p> <p>Conversão da escala de temperatura</p>		

Seleção do cesto

	 <p>4L</p>	 <p>7L</p>	
 <p>Cesto superior</p>			
 <p>Cesto inferior</p>			
 <p>Função Ligação</p>			
 <p>Função Fim de Sincronização</p>			

EN
BG
CZ
DE
DK
EE
FI
FR
GR
HR
HU
IT
LT
LV
NO
NL
PL
PT
RO
RU
SE
SI
SK
SR
TR
UA
ES
GE
AL

Funções predefinidas

					
Air Fry	180°C	15min	60-200°C	1-99min	
	170°C	10min	60-200°C	1-99min	
	140°C	15min	60-200°C	1-99min	
	180°C	30min	60-200°C	1-99min	
	200°C	10min	60-200°C	1-99min	
Bake	170°C	15min	60-200°C	1-99min	
Grill	200°C	5min	60-200°C	1-99min	
Dry	80°C	5h	40-80°C	1-5h	

Antes de cozinhar

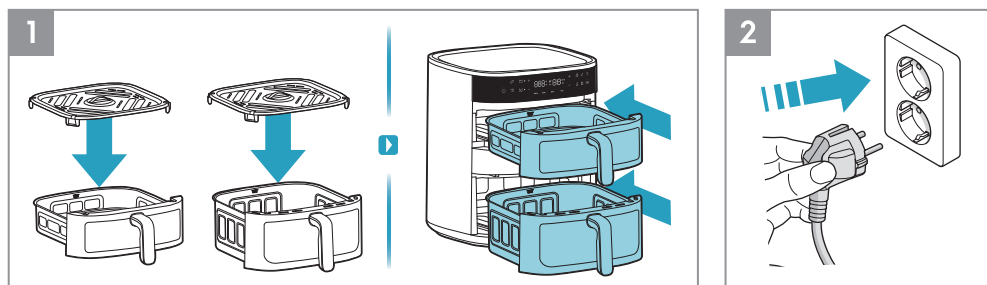

1. Antes de cada cocção, coloque a grelha no cesto (não precisa de remover a base de silicone resistente ao calor da grelha) e introduza completamente o cesto no aparelho.
2. Introduza a ficha de alimentação na tomada elétrica.

Como utilizar - cesto único

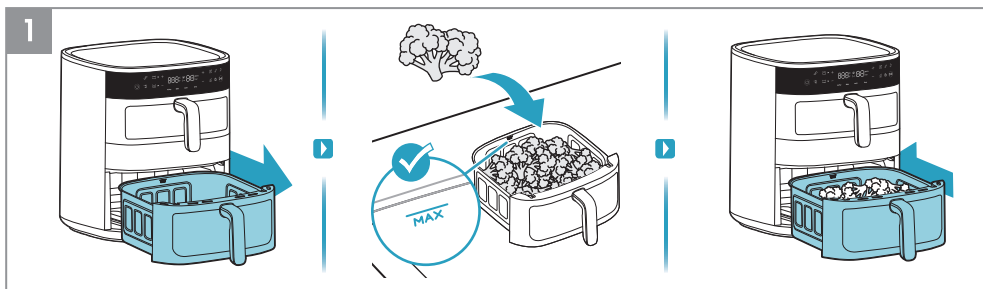

1. Extraia um cesto, coloque-o sobre uma superfície estável e introduza os alimentos no cesto, respeitando a indicação de capacidade "MAX." Em seguida, reintroduza o cesto com alimentos no aparelho.

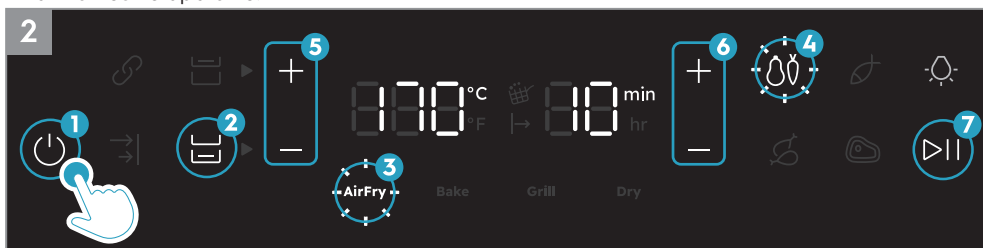

2. Carregue no botão de Ligar / Desligar. Primeiro, selecione o cesto com alimentos. Em seguida, selecione o método de cocção pretendido como, por exemplo, a função Fritar a Ar. Regule o tempo e a temperatura como quiser ou selecione uma das receitas predefinidas como, por exemplo, Vegetais. Por fim, prima o botão Iniciar / Pausar.

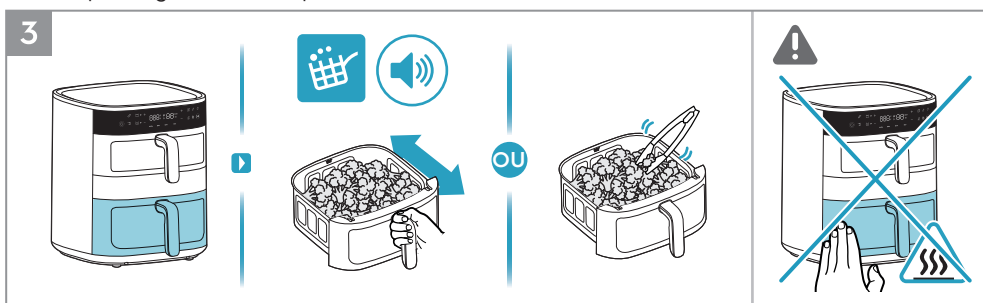

3. Quando o ícone "Aviso para Agitar" se acender e emitir um sinal sonoro durante o processo de cocção, utilize ferramentas resistentes ao calor para dar a volta aos alimentos ou agite, ligeiramente e com cuidado, os alimentos no cesto de fritura.

⚠ **CUIDADO:** Não agite com o cesto de fritura demasiada força para evitar salpicos de alimentos e queimaduras.

⚠ **CUIDADO:** Tenha atenção às superfícies quentes quando estiver a utilizar o aparelho.

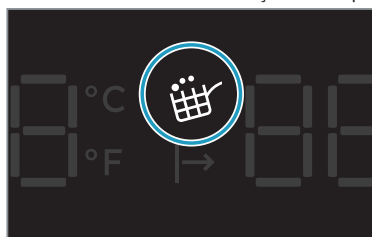

Aviso para Agitar

O "Aviso para Agitar" é ativado durante a função Fritar a Ar e as receitas predefinidas como Vegetais, Peixe, pernas de Frango e Bife.

Quando for o momento de mexer ou virar os alimentos, o ícone de "Aviso para Agitar" acende-se e pisca durante um minuto, ao mesmo tempo que é emitido um sinal sonoro três vezes.

O "Aviso para Agitar" não implica uma ação obrigatória; portanto, a cocção irá continuar normalmente, mesmo que não dê a volta nem mexa os alimentos.



4. No final do tempo de cocção, o aparelho emite um sinal sonoro. Retire o cesto com cuidado e coloque-o numa superfície resistente ao calor. Desligue o aparelho da corrente elétrica depois de o utilizar.

⚠ **CUIDADO:** O cesto pode libertar vapor quente se for extraído a meio ou no fim da cocção. Certifique-se de que o rosto, os braços e as mãos estão afastados do vapor quando o extrair.

Como utilizar - Cesto superior + inferior

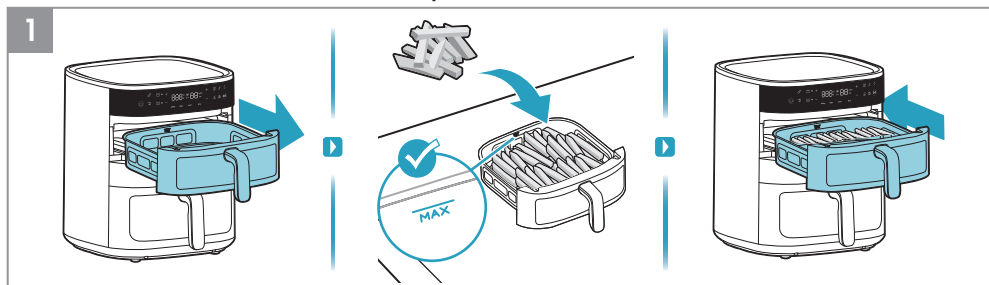

1. Primeiro, retire o cesto superior e coloque nele os alimentos como, por exemplo, batatas fritas.

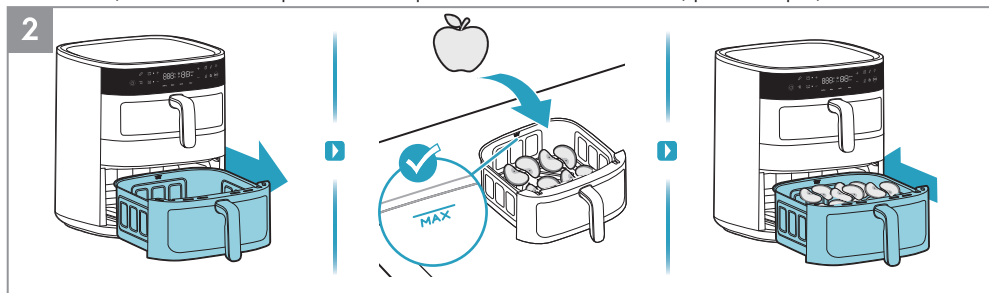

2. Em seguida, retire o cesto inferior e coloque nele os alimentos como, por exemplo, fatias de maçã.



3. Carregue no botão de Ligar / Desligar. Primeiro, selecione o cesto superior. Em seguida, selecione o método de cocção pretendido como, por exemplo, a função Fritar a Ar. Regule o tempo e a temperatura como quiser ou selecione uma das receitas predefinidas como, por exemplo, Vegetais. Por fim, prima o botão Iniciar / Pausar.



4. Depois, seleccione o cesto inferior. Em seguida, seleccione o método de cocção pretendido como, por exemplo, a função Desidratar. Regule o tempo e a temperatura como quiser. Por fim, prima o botão Iniciar / Pausar.

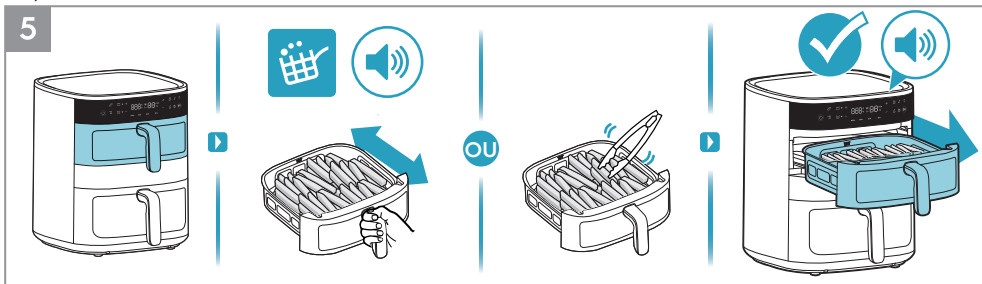

5. Quando o ícone “Aviso para Agitar” se acender e emitir um sinal sonoro durante o processo de cocção, utilize ferramentas resistentes ao calor para dar a volta aos alimentos ou agite, ligeiramente e com cuidado, os alimentos no cesto de fritura. No final do tempo de cocção no cesto superior, o aparelho emite um sinal sonoro.

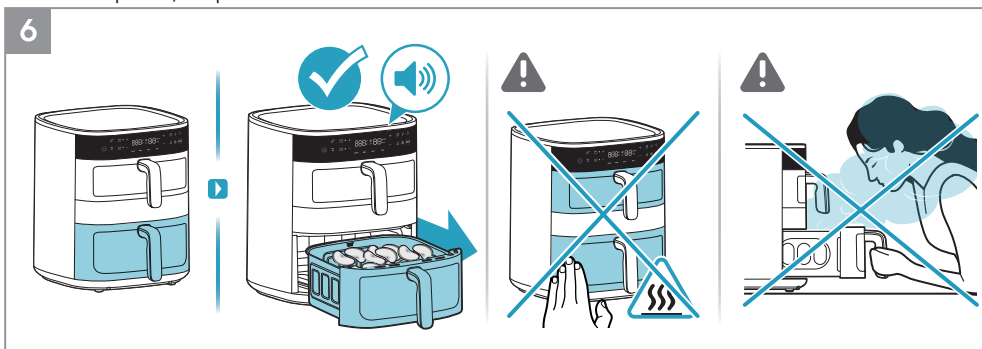

6. No final do tempo de cocção do cesto inferior, o aparelho emite um sinal sonoro.

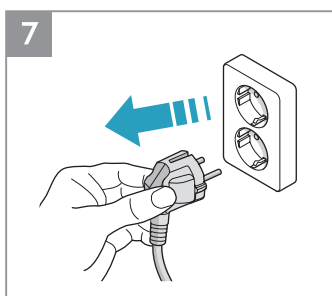

7. Desligue o aparelho da corrente elétrica depois de o utilizar.

EN
BG
CZ
DE
DK
EE
FI
FR
GR
HR
HU
IT
LT
LV
NO
NL
PL
PT
RO
RU
SE
SI
SK
SR
TR
UA
ES
GE
AL

Como utilizar - Função ligação

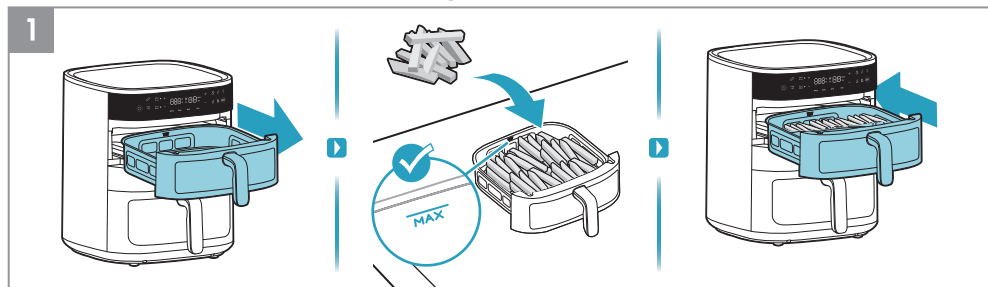

1. Primeiro, retire o cesto superior e coloque nele os alimentos como, por exemplo, batatas fritas.

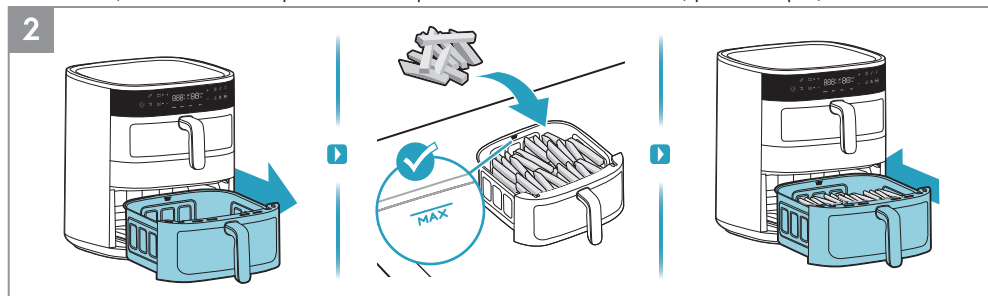

2. Em seguida, retire o cesto inferior e coloque nele os alimentos como, por exemplo, batatas fritas.



3. Carregue no botão de Ligar / Desligar. Primeiro, selecione a função Ligação. Em seguida, selecione o método de cocção pretendido como, por exemplo, a função Fritar a Ar. Regule o tempo e a temperatura como quiser ou selecione uma das receitas predefinidas. Por fim, prima o botão Iniciar / Pausar.

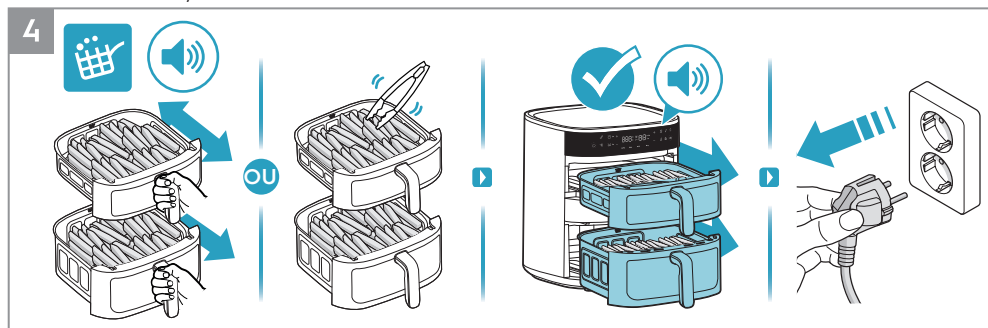

4. Quando o ícone "Aviso para Agitar" se acender e emitir um sinal sonoro durante o processo de cocção, utilize ferramentas resistentes ao calor para dar a volta aos alimentos ou agite, ligeiramente e com cuidado, os alimentos no cesto de fritura. No final do tempo de cocção, o aparelho emite um sinal sonoro. Desligue o aparelho da corrente elétrica depois de o utilizar.

Como utilizar - Função Fim de Sincronização

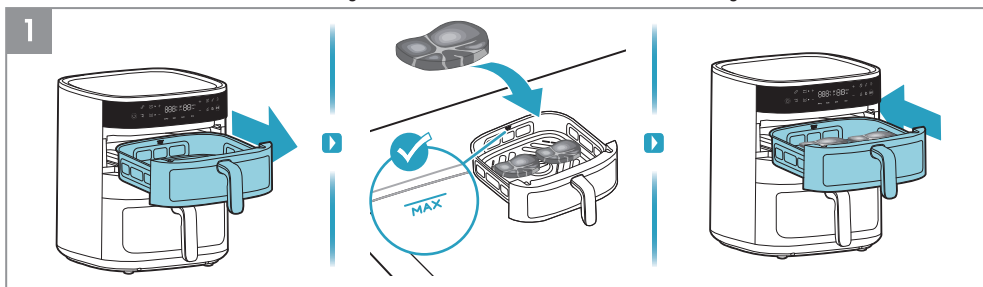

1. Primeiro, retire o cesto superior e coloque nele os alimentos como, por exemplo, bife.

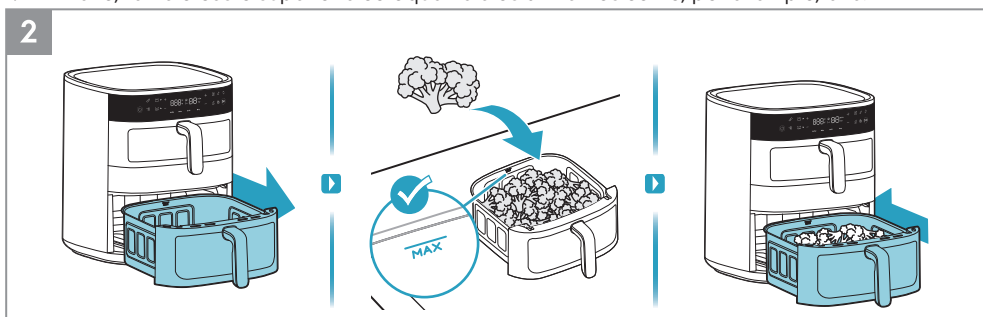

2. Em seguida, retire o cesto inferior e coloque nele os alimentos como, por exemplo, brócolos.



3. Carregue no botão de Ligar / Desligar. Selecione a função Fim de Sincronização. Primeiro, selecione o cesto superior e, em seguida, o método de cocção pretendido como, por exemplo, a função Fritar a Ar. Regule o tempo e a temperatura como quiser ou selecione uma das receitas predefinidas, por exemplo, Bife.



4. E agora selecione o cesto inferior e o método de cocção pretendido como, por exemplo, a função Fritar a Ar. Regule o tempo e a temperatura como quiser ou selecione uma das receitas predefinidas. Por fim, prima o botão Iniciar / Pausar.

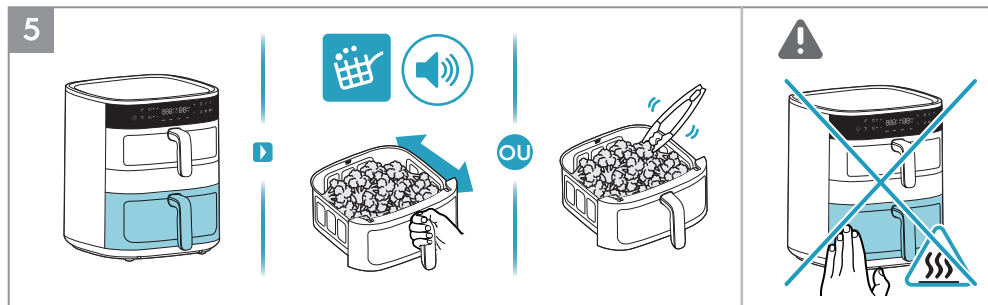

5. Primeiro, o cesto inferior com um tempo definido superior será priorizado para cozinhar. Quando o ícone “Aviso para Agitar” se acender e emitir um sinal sonoro durante o processo de cocção, utilize ferramentas resistentes ao calor para dar a volta aos alimentos ou agite, ligeiramente e com cuidado, os alimentos no cesto de fritura.

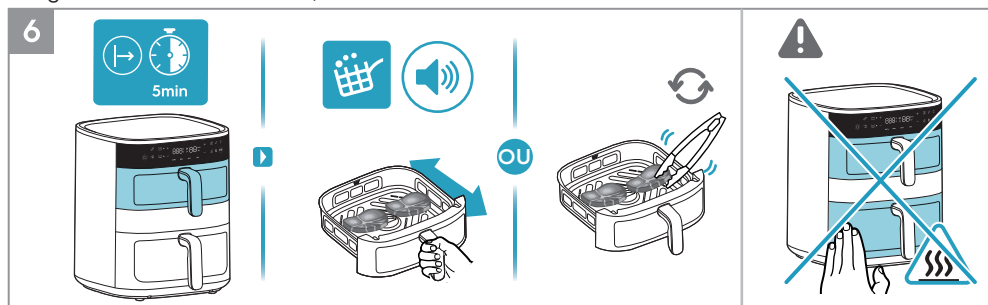

6. depois, o cesto superior com um tempo definido inferior irá iniciar cocção. Quando o ícone “Aviso para Agitar” se acender e emitir um sinal sonoro durante o processo de cocção, utilize ferramentas resistentes ao calor para dar a volta aos alimentos ou agite, ligeiramente e com cuidado, os alimentos no cesto de fritura.

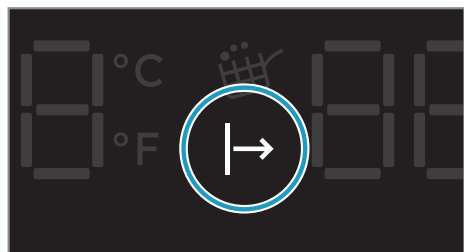

Indicador de Cocção em Espera

Quando a “função Fim de Sincronização” estiver ativada, o cesto com o tempo de cocção inferior aguarda para iniciar a cocção até que o cesto com o tempo de cocção superior efetue a cocção durante algum tempo, para que ambos os cestos possam terminar a cocção em simultâneo. Durante este período, o “indicador de Cocção em Espera” acende-se até que a cocção seja iniciada.

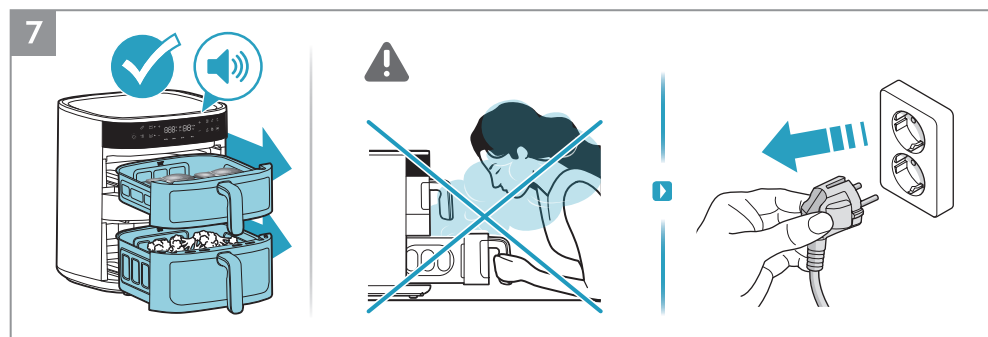

7. No final do tempo de cocção, o aparelho emite um sinal sonoro. Desligue o aparelho da corrente elétrica depois de o utilizar.

Limpeza

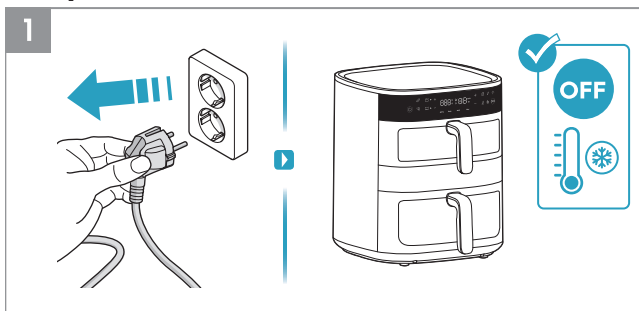

1. Desligue sempre o aparelho da corrente elétrica e aguarde até que arrefeça antes de o limpar.
2. Limpe o exterior do aparelho com um pano macio.

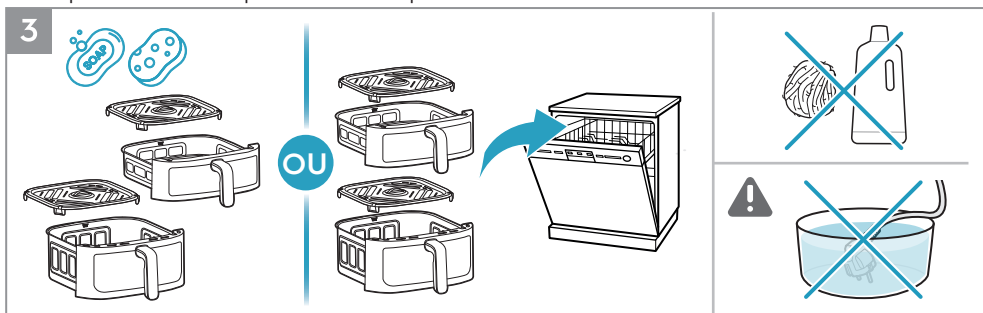

3. Limpe a frigideira e a grelha com água quente e detergente da louça; também pode colocá-las na máquina de lavar louça.

▲NOTA: Evite a utilização de produtos de limpeza abrasivos ou de ferramentas metálicas para proteger o revestimento antiaderente.

CUIDADO: Nunca mergulhe o produto, o cabo ou a ficha elétrica em água ou noutro líquido.

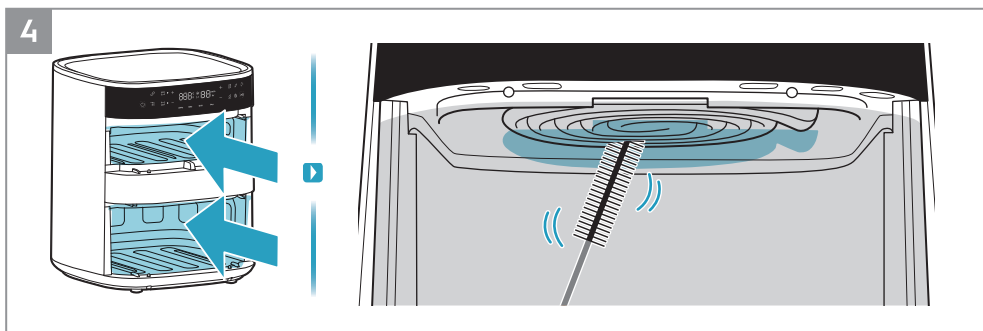











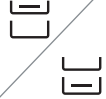



















































4. Limpe o elemento de aquecimento com uma escova de limpeza.

NOTA: Certifique-se de que o aparelho está totalmente frio antes de limpar o elemento de aquecimento.

EN
BG
CZ
DE
DK
EE
FI
FR
GR
HR
HU
IT
LT
LV
NO
NL
PL
PT
RO
RU
SE
SI
SK
SR
TR
UA
ES
GE
AL

Guia de cozinha

							
AirFry	7mm/10mm 	4L 	400g	180°C	18min		
		7L 	400g	180°C	18min		
AirFry		4L 	400g	170°C	8min		
		7L 	400g	170°C	10min		
AirFry		4L 	400g/2pçs.	140°C	15min		
		7L 	400g/2pçs.	140°C	15min		
AirFry		4L 	1000g/8pçs.	180°C	28min		
		7L 	1000g/8pçs.	180°C	28min		
AirFry		4L 	400g/2pçs.	200°C	10min		
		7L 	400g/2pçs.	200°C	10min		
AirFry		4L 	220g/6cm	160°C	12min		
		7L 	220g/6cm	160°C	14min		

							
AirFry		 7L	1200g	180°C	55min		
AirFry		 7L	400g/9pçs.	160°C	20min		
Grill		 4L	180g/4pçs.	180°C	8min		
		 7L	180g/4pçs.	180°C	9min		
Dry		 4L	180g	80°C	3h		
		 7L	180g	80°C	3h		
Dry		 4L	200g	80°C	3h		
		 7L	200g	80°C	3h		

- EN
- BG
- CZ
- DE
- DK
- EE
- FI
- FR
- GR
- HR
- HU
- IT
- LT
- LV
- NO
- NL
- PL
- PT**
- RO
- RU
- SE
- SI
- SK
- SR
- TR
- UA
- ES
- GE
- AL

O que fazer se...

Problema	Verificar se...
Não conseguir ativar ou utilizar o aparelho.	<ul style="list-style-type: none"> • O aparelho está ligado corretamente à alimentação elétrica. • Os cestos estão na posição correta. Certifique-se de que estão completamente inseridos no aparelho para permitir a alimentação elétrica. • O tempo de cocção está definido.
Não conseguir introduzir o cesto no aparelho.	<ul style="list-style-type: none"> • A capacidade do cesto foi ultrapassada. • O cesto está colocado corretamente. Deve emitir um estalido ao ser colocado na unidade. • Existe um objeto sob o cesto a impedir que feche corretamente.
O aparelho liberta fumo branco.	<ul style="list-style-type: none"> • A comida preparada é demasiado oleosa. • O cesto, a grelha e o elemento de aquecimento estão limpos.
O visor apresenta E1	• Circuito aberto do cesto superior.
O visor apresenta E2	• Curto-circuito do cesto superior.
O visor apresenta E3	• Circuito aberto do cesto inferior.
O visor apresenta E4	• Curto-circuito no cesto inferior.
O visor apresenta E5	• Falha de comunicação da PCBA de controlo.
O visor apresenta E6	• Falha de comunicação da PCBA de alimentação.

* Caso o visor apresente códigos de erro, o aparelho deve ser reparado por um Centro de Assistência Técnica.

Dados técnicos

Produto	Fritadeira a ar
Modelo	EAFD11B
Tensão (V~)	220 V - 240 V
Potência (W)	2700 W
Frequência (Hz)	50 - 60 Hz
Capacidade	4 L + 7 L



Manual de instrucțiuni

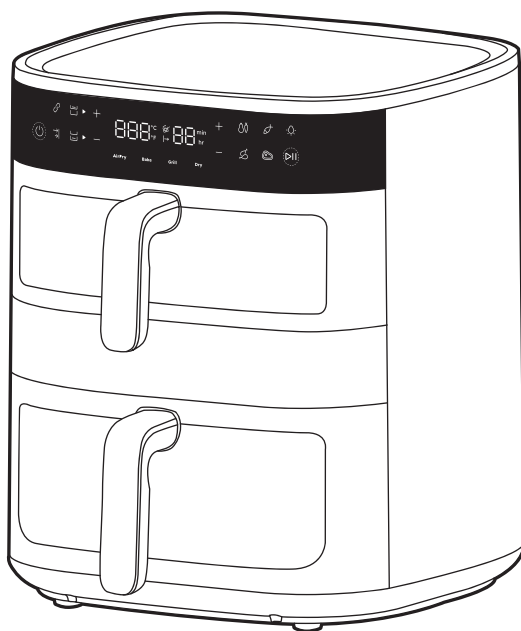

Friteuză cu aer cald Dual 800

Prezentare generală

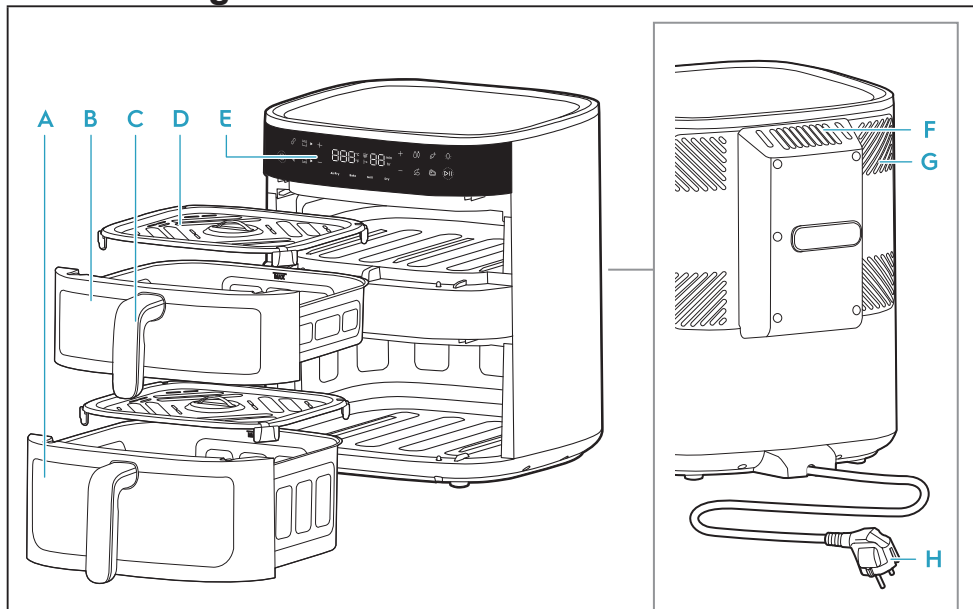

- A** Coș inferior (7 L) **C** Mâner coș **E** Panou de comandă **G** Sistem de răcire
- B** Coș superior (4 L) **D** Grătar **F** Orificiu evacuare aer **H** Cablu principal

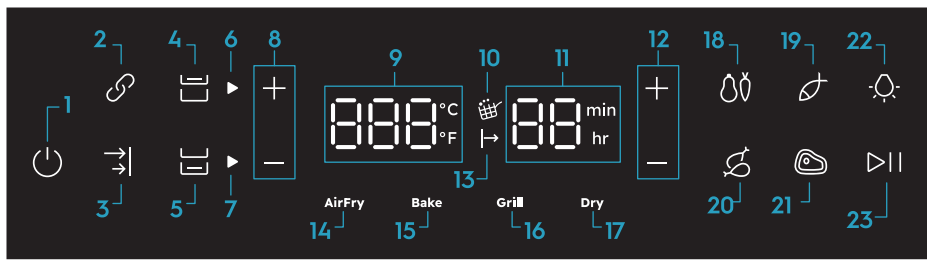

- | | | | |
|--|--|--|--|
| <ul style="list-style-type: none"> 1. Pornire/Oprire 2. Funcție sincronizare setări coșuri 3. Funcție sincronizare temporizator coșuri 4. Control coș superior 5. Control coș inferior 6. Indicator coș superior | <ul style="list-style-type: none"> 7. Indicator coș inferior 8. Control temperatură 9. Indicator temperatură (40-200°C) 10. Memento amestecare | <ul style="list-style-type: none"> 11. Indicator timp (Fritează cu aer cald: 1-99 min, Deshidratare: 1-5 h) 12. Control timp 13. Programare gătire 14. Funcție fritează cu aer cald 15. Funcție coacere | <ul style="list-style-type: none"> 16. Funcție grătar 17. Funcție uscare 18. Legume 19. Pește 20. Pui 21. Friptură 22. Control iluminat 23. Redare/Pauză |
|--|--|--|--|

Înainte de prima utilizare

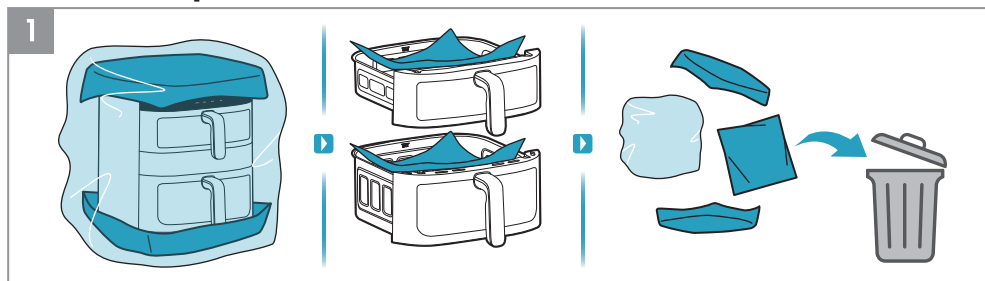

1. Îndepărtați toate ambalajele și materialele de protecție.

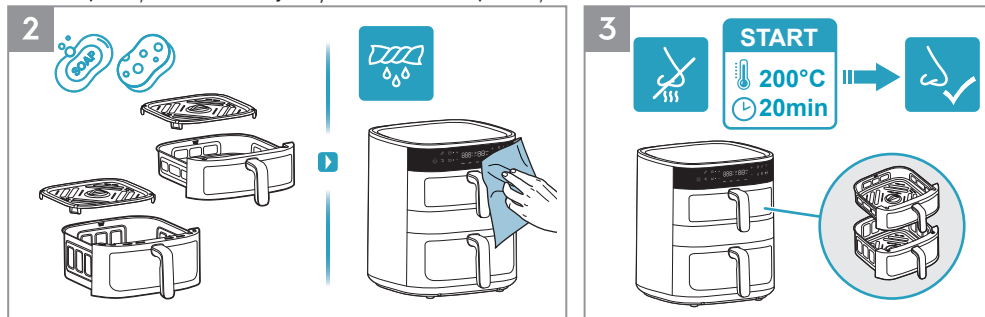

2. Curățați coșul și grătarul cu apă caldă și detergent de vase. Ștergeți interiorul și exteriorul aparatului cu o lavetă moale.

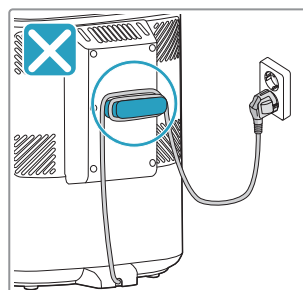
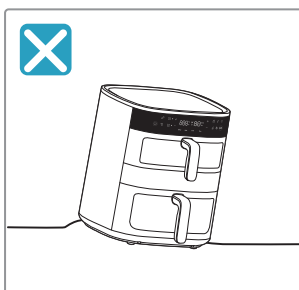
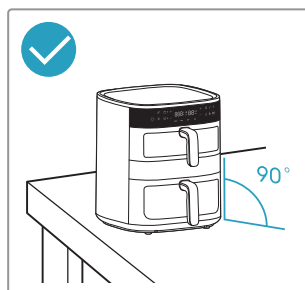
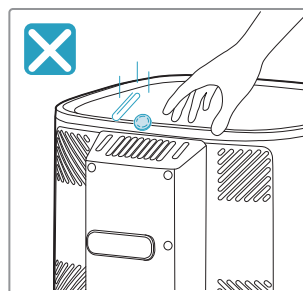
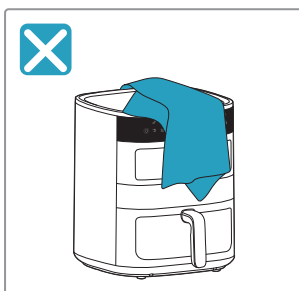
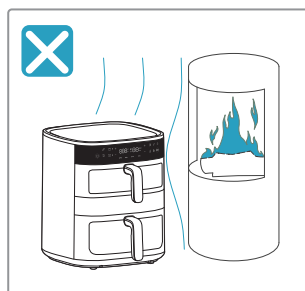

3. Este normal ca o unitate nouă să emane mirosuri la primele câteva utilizări. Lăsați friteuza goală să funcționeze la 200°C timp de 20 de minute înainte de prima utilizare, pentru a evita acest lucru.

! Măsurile de siguranță





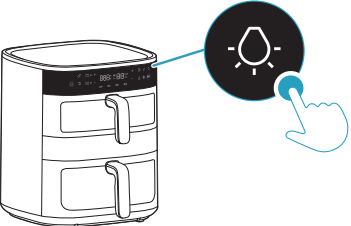
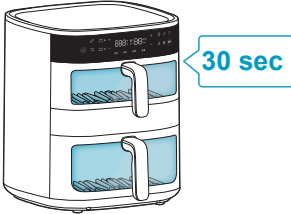

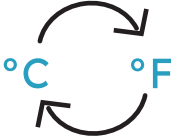









EN
BG
CZ
DE
DK
EE
FI
FR
GR
HR
HU
IT
LT
LV
NO
NL
PL
PT
RO
RU
SE
SI
SK
SR
TR
UA
ES
GE
AL







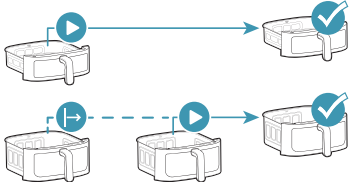







Controlul iluminatului și conversia scalei de temperatură

 <p>Control iluminat</p>		
<p>°C/°F</p> <p>Conversia scalei de temperatură</p>		

Selectarea coșului

	 <p>4L</p>	 <p>7L</p>	
 <p>Coș superior</p>			
 <p>Coș inferior</p>			
 <p>Funcție sincronizare setări coșuri</p>			
 <p>Funcție sincronizare temporizator coșuri</p>			

Funcții presetate

 AirFry					
AirFry	180°C	15min	60~200°C	1~99min	
	170°C	10min	60~200°C	1~99min	
	140°C	15min	60~200°C	1~99min	
	180°C	30min	60~200°C	1~99min	
	200°C	10min	60~200°C	1~99min	
Bake	170°C	15min	60~200°C	1~99min	
Grill	200°C	5min	60~200°C	1~99min	
Dry	80°C	5h	40~80°C	1~5h	

Înainte de a găti

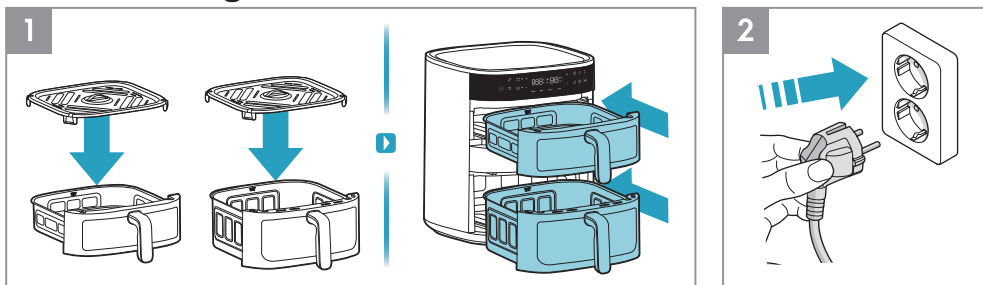

1. De fiecare dată, înainte de a găti, vă rugăm să așezați grătarul în coș (nu este nevoie să îndepărtați suportul din silicon rezistent la căldură al grătarului) și să împingeți complet coșul în aparat.
2. Introduceți ștecăru în priză.

Mod de utilizare - Coș individual

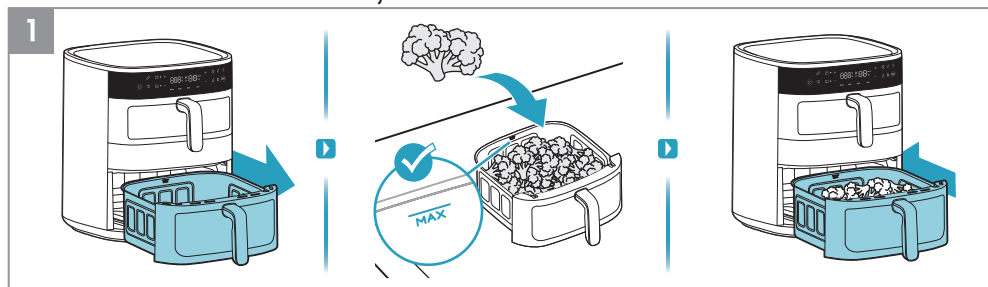

1. Scoateți un coș și așezați-l pe o suprafață stabilă, puneți alimentele în coș, respectând indicația de capacitate "MAX". Apoi împingeți coșul cu alimente complet înapoi în aparat.



2. Apăsați butonul Pornire/Oprire. Mai întâi selectați coșul cu mâncare. Apoi selectați metoda de gătit dorită, de exemplu, funcția Friteuză cu aer cald. Reglați timpul și temperatura după gust sau selectați una dintre rețetele prestabilite, de exemplu, Legume. La final, apăsați butonul Redare/Pauză.

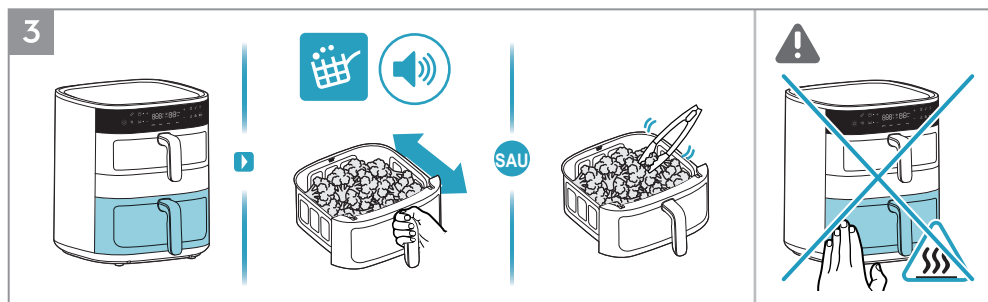

3. Când pictograma "Memento amestecare" se aprinde și emite un semnal sonor în timpul procesului de gătit, folosiți unelte rezistente la căldură pentru a întoarce mâncarea o dată sau agitați ușor mâncarea din coș.

⚠ **ATENȚIE:** Nu agitați puternic coșul pentru a evita stropirea cu mâncare și arsurile pielii.

⚠ **ATENȚIE:** Aveți grijă la suprafețele fierbinți atunci când aparatul este în funcțiune.

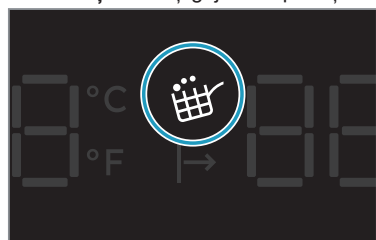

Memento amestecare

"Memento amestecare" este activat în timpul funcției Friteuză cu aer cald și a rețetelor pre-setate, cum ar fi legume, pește, pulpe de pui și friptură.

Când este momentul să amestecați sau să întoarceți mâncarea, pictograma "Memento amestecare" se va aprinde și va clipi timp de un minut, în timp ce un semnal sonor se va repeta de trei ori.

"Memento amestecare" nu este obligatoriu, prin urmare, gătitul va continua ca de obicei, chiar dacă mâncarea nu este întoarsă sau agitată.

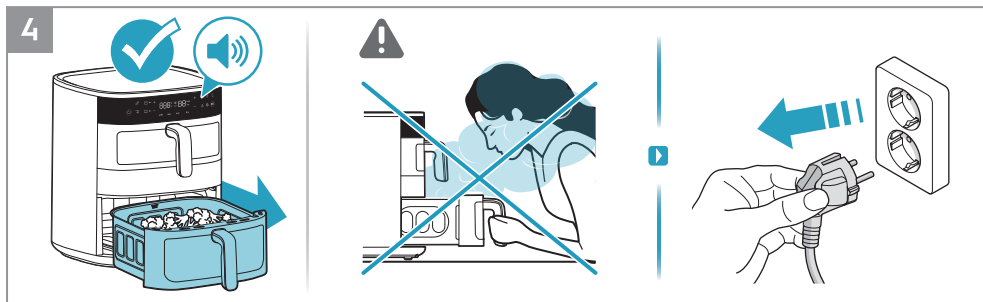

4. La sfârșitul timpului de gătire, aparatul va emite un semnal sonor. Scoateți cu grijă coșul și așezați-l pe o suprafață rezistentă la căldură. Deconectați aparatul de la priză după utilizare.

⚠ **ATENȚIE:** Din coș poate ieși abur fierbinte atunci când acesta este deschis în mijlocul sau la sfârșitul procesului de gătire. Asigurați-vă că fața, brațele și mâinile nu intră în contact cu aburul atunci când îl deschideți.

Mod de utilizare - Coș superior + inferior

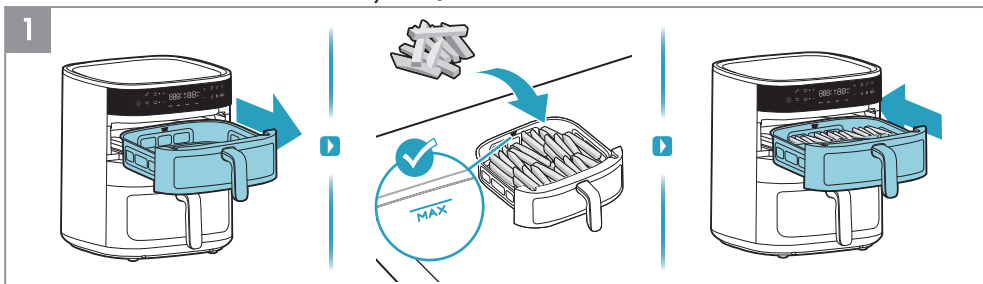

1. Mai întâi, scoateți coșul superior și puneți alimentele în coș, de exemplu, cartofi prăjiți.

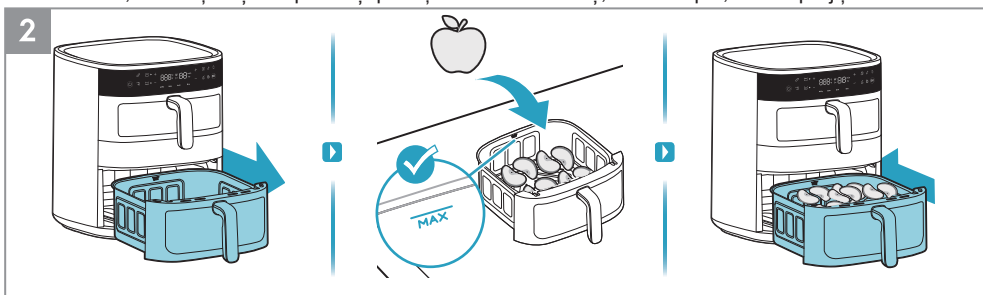

2. Apoi, scoateți coșul inferior și puneți alimentele în coș, de exemplu, felii de măr.



3. Apăsăți butonul Pornire/Oprire. Selectați întâi coșul superior. Apoi selectați metoda de gătit dorită, de exemplu, funcția Fritează cu aer cald. Reglați timpul și temperatura după gust sau selectați una dintre rețetele prestabilite, de exemplu, Legume. La final, apăsați butonul Redare/Pauză.



4. Apoi, selectați coșul inferior. Apoi selectați metoda de gătit dorită, de exemplu, funcția Uscare. Reglați timpul și temperatura după gust. La final, apăsați butonul Redare/Pauză.

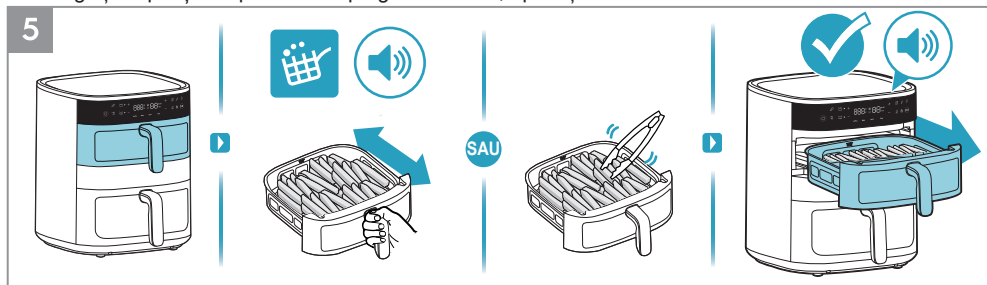

5. Când pictograma “Memento amestecare” se aprinde și emite un semnal sonor în timpul procesului de gătire, folosiți unelte rezistente la căldură pentru a întoarce mâncarea o dată sau agitați ușor mâncarea din coș. La sfârșitul timpului de gătire al coșului superior, aparatul va emite un semnal sonor.

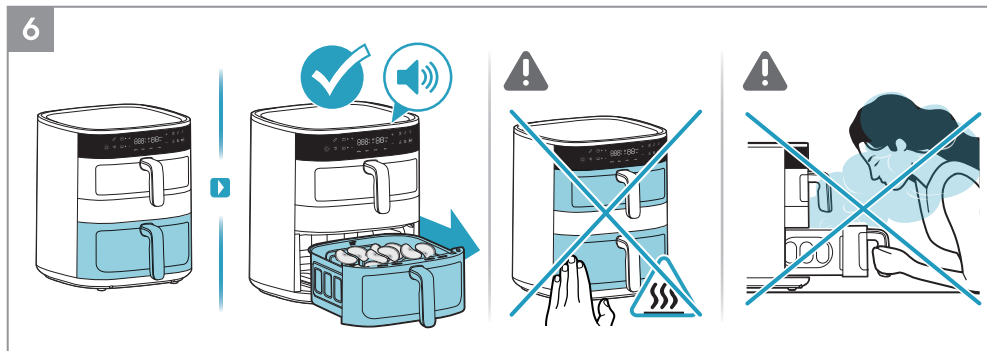

6. La sfârșitul timpului de gătire al coșului inferior, aparatul va emite un semnal sonor.

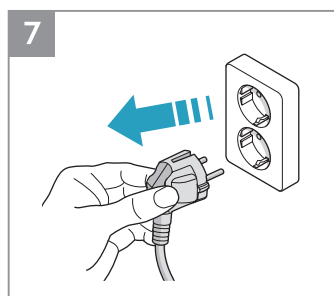

7. Deconectați aparatul de la priză după utilizare.

Mod de utilizare - Funcție sincronizare setări coșuri

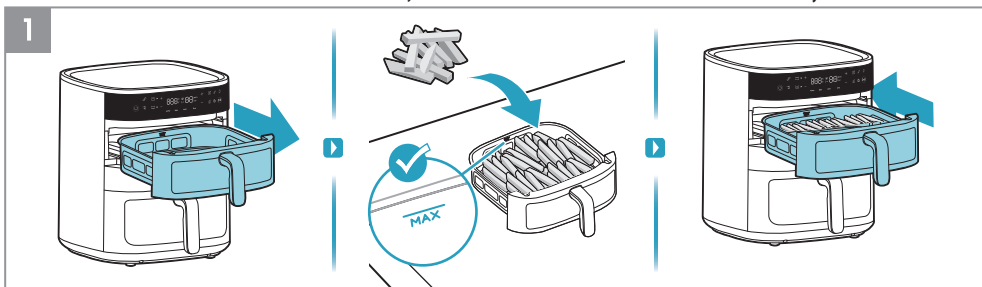

1. Mai întâi, scoateți coșul superior și puneți alimentele în coș, de exemplu, cartofi prăjiți.

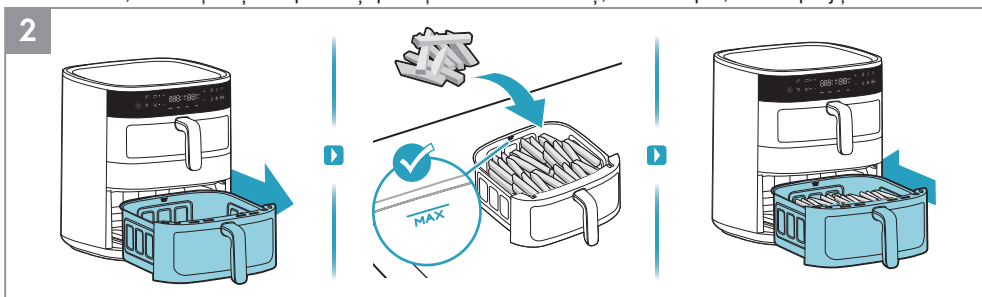

2. Apoi, scoateți coșul inferior și puneți alimentele în coș, de exemplu, cartofi prăjiți.



3. Apăsați butonul Pornire/Opreire. Selectați întâi funcția de sincronizare setări coșuri. Apoi selectați metoda de gătit dorită, de exemplu, funcția Fritează cu aer cald. Reglați timpul și temperatura după gust sau selectați una dintre rețetele prestabilite. La final, apăsați butonul Redare/Pauză.

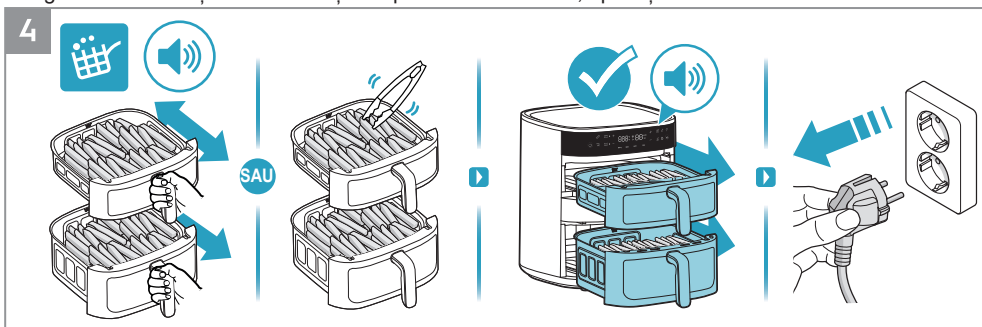

4. Când pictograma “Memento amestecare” se aprinde și emite un semnal sonor în timpul procesului de gătit, folosiți unelte rezistente la căldură pentru a întoarce mâncarea o dată sau agitați ușor mâncarea din coș. La sfârșitul timpului de gătit, aparatul va emite un semnal sonor. Deconectați aparatul de la priză după utilizare.

EN
BG
CZ
DE
DK
EE
FI
FR
GR
HR
HU
IT
LT
LV
NO
NL
PL
PT
RO
RU
SE
SI
SK
SR
TR
UA
ES
GE
AL

Mod de utilizare - Funcție sincronizare temporizator coșuri

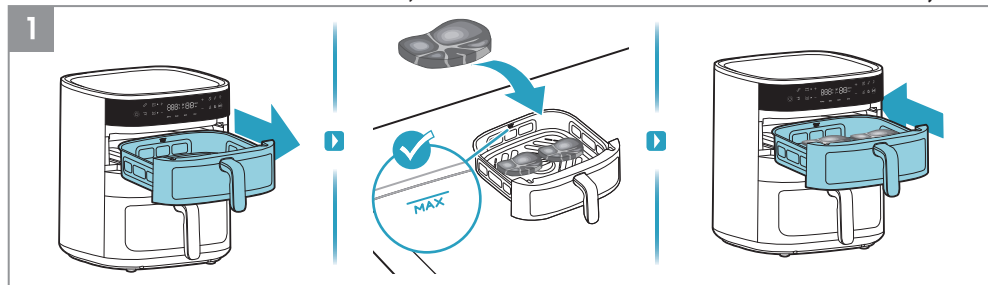

1. Mai întâi, scoateți coșul superior și puneți alimentele în coș, de exemplu, friptură.

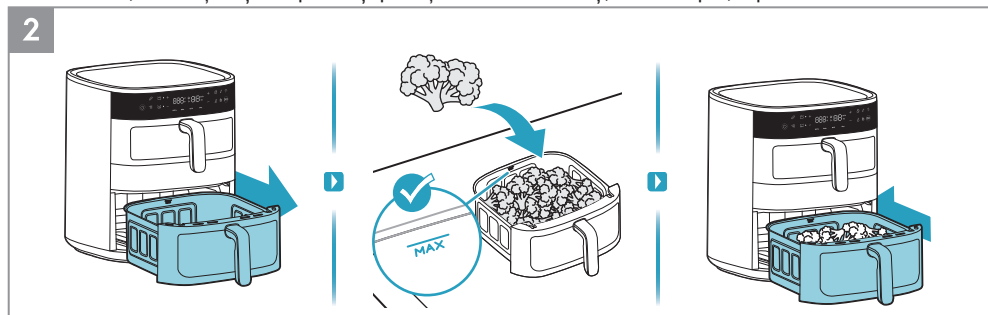

2. Apoi, scoateți coșul inferior și puneți alimentele în coș, de exemplu, broccoli.



3. Apăsați butonul Pornire/Oprire. Selectați funcția sincronizare temporizator coșuri. Selectați întâi coșul superior, apoi selectați metoda de gătit dorită, de exemplu, funcția Fritează cu aer cald. Reglați timpul și temperatura după gust sau selectați una dintre rețetele prestabilite, de exemplu, Friptură.

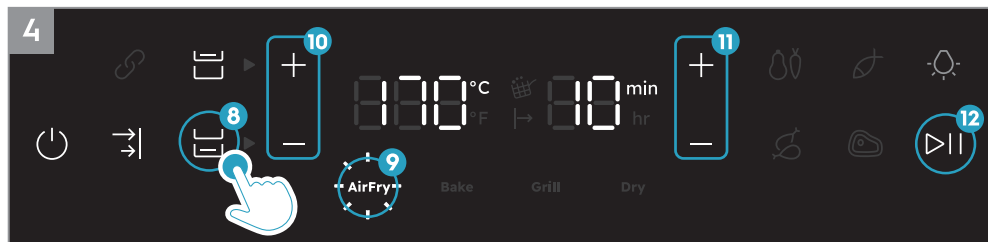

4. Selectați apoi coșul inferior și selectați metoda de gătit dorită, de exemplu, funcția Fritează cu aer cald. Reglați timpul și temperatura după gust sau selectați una dintre rețetele prestabilite. La final, apăsați butonul Redare/Pauză.

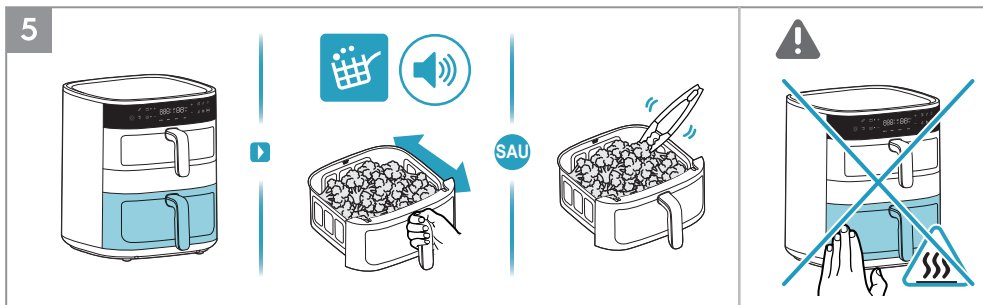

5. În primul rând, coșul inferior, cu un timp de gătire mai lung, va fi prioritar pentru gătit. Când pictograma "Memento amestecare" se aprinde și emite un semnal sonor în timpul procesului de gătire, folosiți unele rezistente la căldură pentru a întoarce mâncarea o dată sau agitați ușor mâncarea din coș.

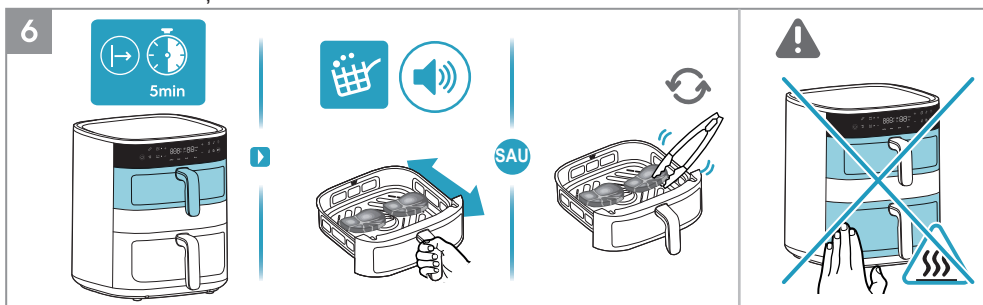

6. În al doilea rând, coșul superior, cu un timp de gătire mai scurt, va începe să gătească. Când pictograma "Memento amestecare" se aprinde și emite un semnal sonor în timpul procesului de gătire, folosiți unele rezistente la căldură pentru a întoarce mâncarea o dată sau agitați ușor mâncarea din coș.

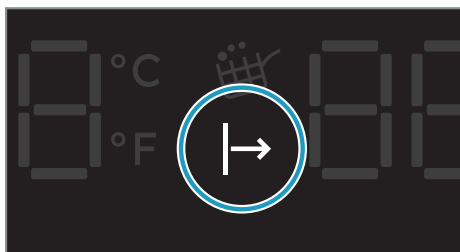

Indicator programare gătire

Când este activată "Funcția sincronizare temporizator coșuri", coșul cu un timp de gătire mai scurt va aștepta gătitul până când coșul cu un timp de gătire mai lung gătește o perioadă, astfel încât ambele coșuri să poată încheia gătitul simultan. În această perioadă, "Indicatorul programare gătire" se va aprinde până la începerea gătitului.

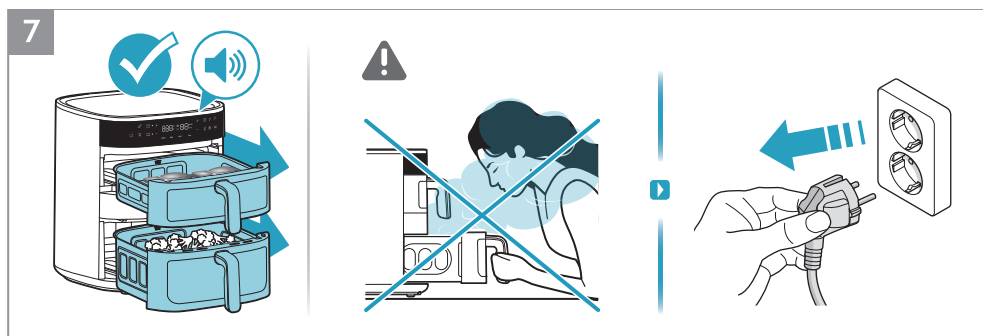

7. La sfârșitul timpului de gătire, aparatul va emite un semnal sonor. Deconectați aparatul de la priză după utilizare.

Curățare

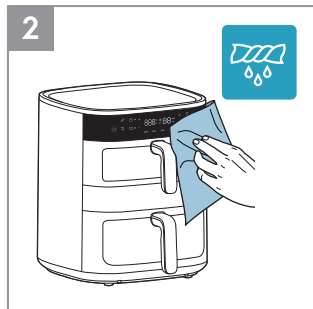
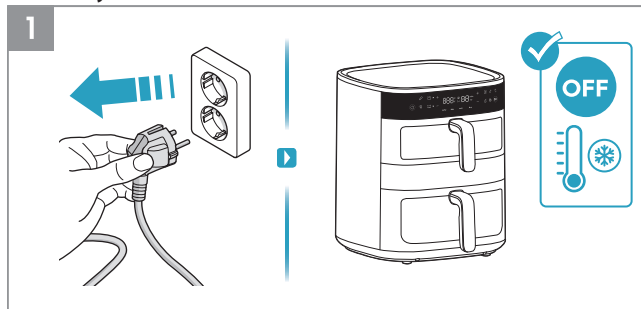

1. Deconectați întotdeauna aparatul de la priză și așteptați până se răcește înainte de a-l curăța.
2. Ștergeți exteriorul aparatului cu o lavetă moale.

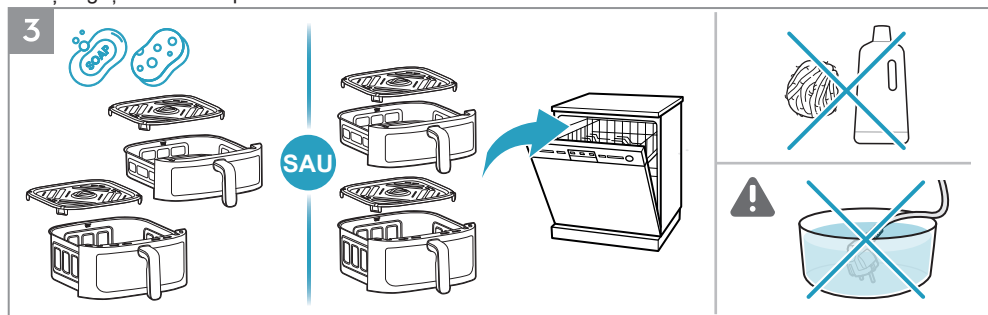

3. Curățați coșul și grătarul cu apă caldă și detergent de vase sau puneți-le în mașina de spălat vase.

▲OBSERVAȚII: Evitați utilizarea produselor de curățare abrazive sau a uneltelor metalice pentru a proteja stratul antiaderent.



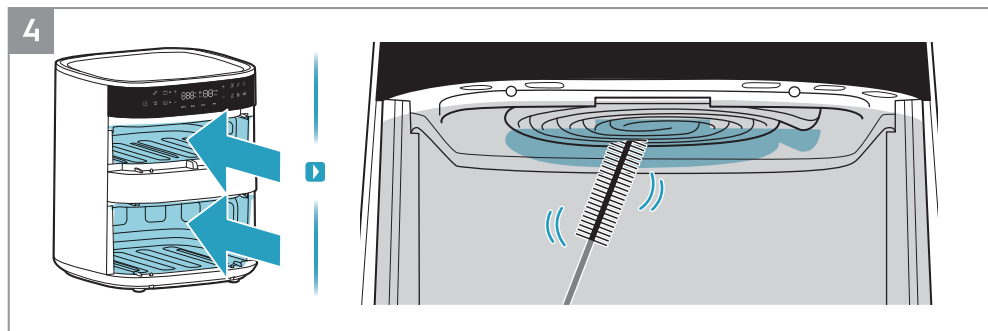









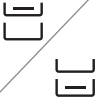

























ATENȚIE: Nu scufundați niciodată produsul, cablul sau ștecărul acestuia în apă sau în orice alt lichid.



4. Curățați elementul de încălzire cu o perie de curățare.













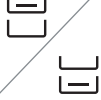











OBSERVAȚII: Asigurați-vă că aparatul s-a răcit complet înainte de a curăța elementul de încălzire.

Ghid de gătit

							
AirFry	7mm/10mm 	 4L	400g	180°C	18min		
		 7L	400g	180°C	18min		
AirFry		 4L	400g	170°C	8min		
		 7L	400g	170°C	10min		
AirFry		 4L	400g/2bucăți	140°C	15min		
		 7L	400g/2bucăți	140°C	15min		
AirFry		 4L	1000g/8bucăți	180°C	28min		
		 7L	1000g/8bucăți	180°C	28min		
AirFry		 4L	400g/2bucăți	200°C	10min		
		 7L	400g/2bucăți	200°C	10min		
AirFry		 4L	220g/6/15 cm	160°C	12min		
		 7L	220g/6/15 cm	160°C	14min		

- EN
- BG
- CZ
- DE
- DK
- EE
- FI
- FR
- GR
- HR
- HU
- IT
- LT
- LV
- NO
- NL
- PL
- PT
- RO**
- RU
- SE
- SI
- SK
- SR
- TR
- UA
- ES
- GE
- AL

EN
BG
CZ
DE
DK
EE
FI
FR
GR
HR
HU
IT
LT
LV
NO
NL
PL
PT
RO
RU
SE
SI
SK
SR
TR
UA
ES
GE
AL

							
AirFry		7L 	1200g	180°C	55min		
AirFry		7L 	400g/9bucăți	160°C	20min		
Grill		4L 	180g/4bucăți	180°C	8min		
		7L 	180g/4bucăți	180°C	9min		
Dry		4L 	180g	80°C	3h		
		7L 	180g	80°C	3h		
Dry		4L 	200g	80°C	3h		
		7L 	200g	80°C	3h		

Ce să faceți dacă...

Problemă	Verificați dacă...
Nu puteți activa sau utiliza aparatul.	<ul style="list-style-type: none">• Aparatul este conectat corect la o priză electrică.• Coșurile sunt în poziția corectă. Asigurați-vă că sunt complet introduse în aparat pentru a permite alimentarea cu energie electrică.• Timpul de gătire este setat.
Nu puteți introduce coșul în aparat.	<ul style="list-style-type: none">• Coșul este umplut peste capacitatea sa maximă.• Coșul este pus corect. Trebuie să audă un clic când îl așezați în unitate.• Sub coș se află un obiect care împiedică închiderea corectă a acestuia.
Din aparat iese fum alb.	<ul style="list-style-type: none">• Mâncarea pe care o pregătiți este prea grasă.• Coșul, grătarul și elementul de încălzire sunt curate.
Afișajul arată E1	<ul style="list-style-type: none">• Circuit deschis coș superior.
Afișajul arată E2	<ul style="list-style-type: none">• Scurtcircuit la coșul superior.
Afișajul arată E3	<ul style="list-style-type: none">• Circuit deschis coș inferior.
Afișajul arată E4	<ul style="list-style-type: none">• Scurtcircuit la coșul inferior.
Afișajul arată E5	<ul style="list-style-type: none">• Controlează defecțiunea comunicării PCBA.
Afișajul arată E6	<ul style="list-style-type: none">• Eroarea comunicării PCBA de alimentare.

* În cazul în care pe afișaj apar coduri de eroare, aparatul trebuie reparat de un Centru de service.

Date tehnice

Produs	Friteuză cu aer cald
Model	EAFD11B
Voltaj (V~)	220 V ~ 240 V
Putere (W)	2700 W
Frecvență (Hz)	50 ~ 60 Hz
Capacitate	4 L + 7 L



Инструкция по эксплуатации

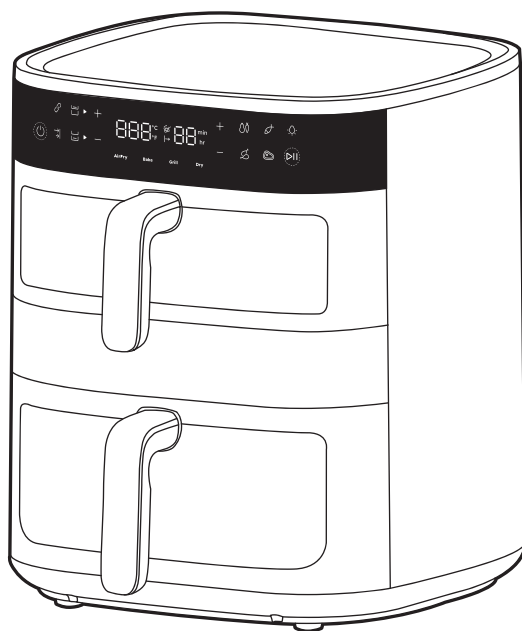

Двойная аэрофритюрница серии **800**

Общий обзор

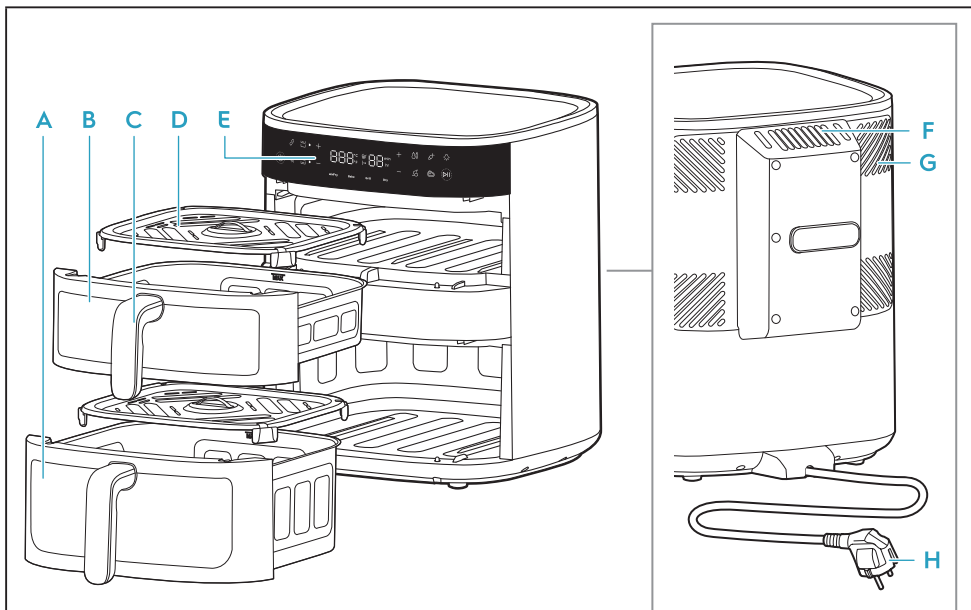

- A** Нижняя корзина (7 л) **C** Ручка корзины **E** Панель управления **G** Система охлаждения
B Верхняя корзина (4 л) **D** Решетка **F** Выход воздуха **H** Шнур питания

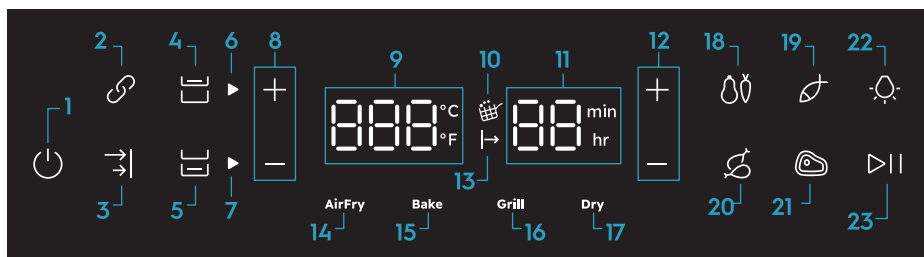

- | | | | |
|--|--|--------------------------------------|---------------------------|
| 1. Включение/выключение | 7. Индикатор нижней корзины | 12. Регулировка времени | 17. Функция сушки (Dry) |
| 2. Функция сопряжения | 8. Регулировка температуры | 13. Ожидание приготовления | 18. Овощи |
| 3. Функция синхронизации окончания приготовления | 9. Индикатор температуры (40-200 °C) | 14. Функция воздушной жарки (AirFry) | 19. Рыба |
| 4. Управление верхней корзиной | 10. Напоминание о перемешивании | 15. Функция выпекания (Bake) | 20. Курица |
| 5. Управление нижней корзиной | 11. Индикатор времени (Воздушная жарка: 1-99 мин, Дегидратация: 1-5 ч) | 16. Функция гриля (Grill) | 21. Стейк |
| 6. Индикатор верхней корзины | | | 22. Управление подсветкой |
| | | | 23. Пуск/Приостановка |

Перед первым использованием

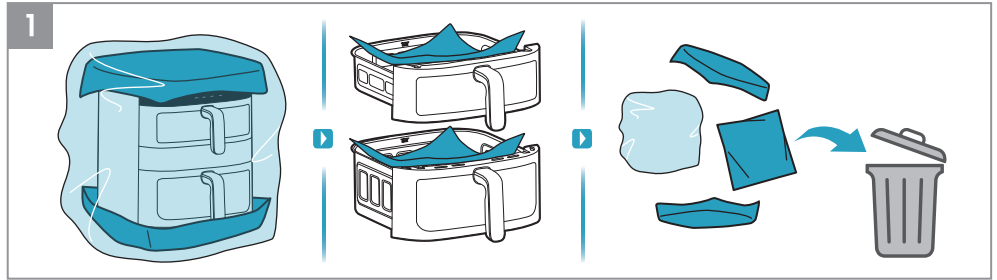

1. Удалите всю упаковку и защитный материал.

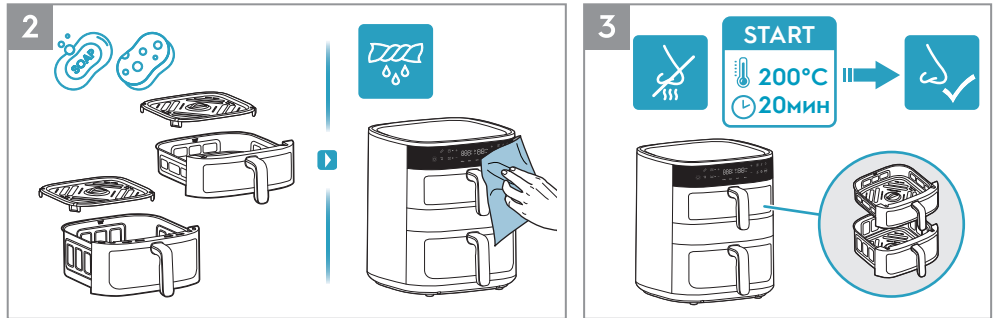



2. Очистите корзину и решетку теплой водой с добавлением средства для мытья посуды. Протрите внутреннюю и внешнюю поверхности устройства мягкой тканью.
3. Во время первых нескольких использований нового устройства выделение запахов является нормальным явлением. Чтобы избежать этого, перед первым использованием прогрейте пустую аэрофритюрницу при температуре 200 °C в течение 20 минут.

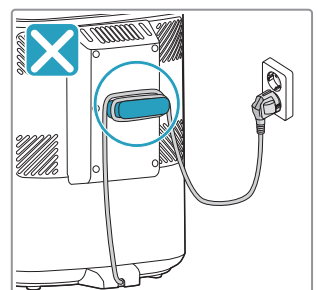
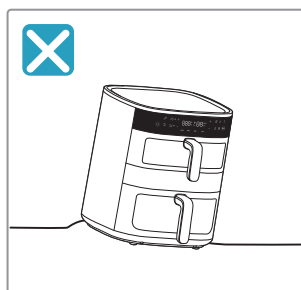
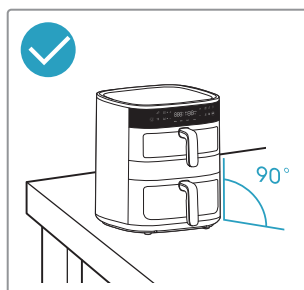
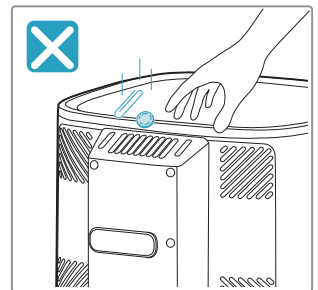
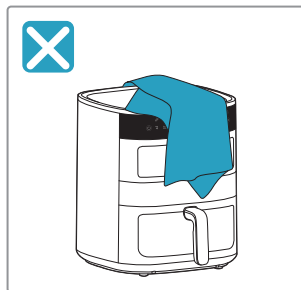
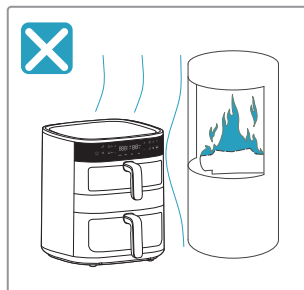



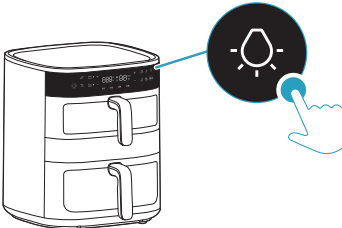
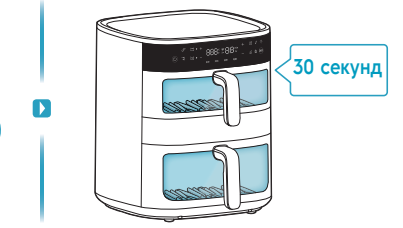

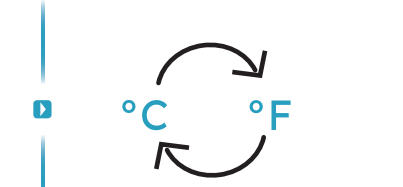



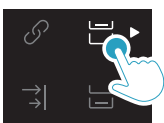



! Меры безопасности



Управление подсветкой и переключение шкалы температур





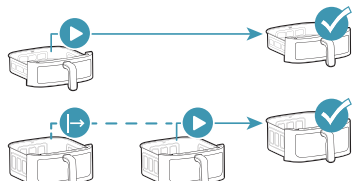





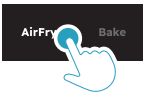



 <p>Управление подсветкой</p>		
<p>°C/°F</p> <p>Переключение шкалы температур</p>		

Выбор корзины

	 <p>4л</p>	 <p>7л</p>	
 <p>Верхняя корзина</p>			
 <p>Нижняя корзина</p>			
 <p>Функция сопряжения</p>			
 <p>Функция синхронизации окончания приготовления</p>			

EN
BG
CZ
DE
DK
EE
FI
FR
GR
HR
HU
IT
LT
LV
NO
NL
PL
PT
RO
RU
SE
SI
SK
SR
TR
UA
ES
GE
AL

Предустановленные функции

					
Air Fry	180°C	15мин	60-200°C	1-99мин	
	170°C	10мин	60-200°C	1-99мин	
	140°C	15мин	60-200°C	1-99мин	
	180°C	30мин	60-200°C	1-99мин	
	200°C	10мин	60-200°C	1-99мин	
Bake	170°C	15мин	60-200°C	1-99мин	
Grill	200°C	5мин	60-200°C	1-99мин	
Dry	80°C	5ч	40-80°C	1-5ч	

Перед приготовлением

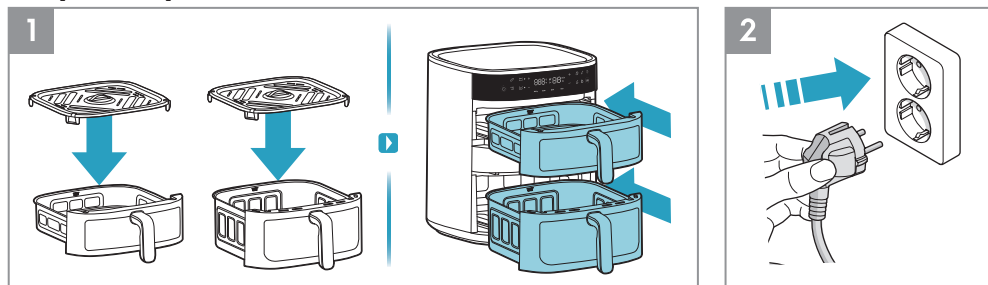

1. Перед каждым приготовлением поместите решетку в корзину (термостойкую силиконовую подставку решетки снимать не нужно) и полностью вставьте корзину в устройство.
2. Вставьте вилку шнура питания в розетку.

Порядок использования — одна корзина

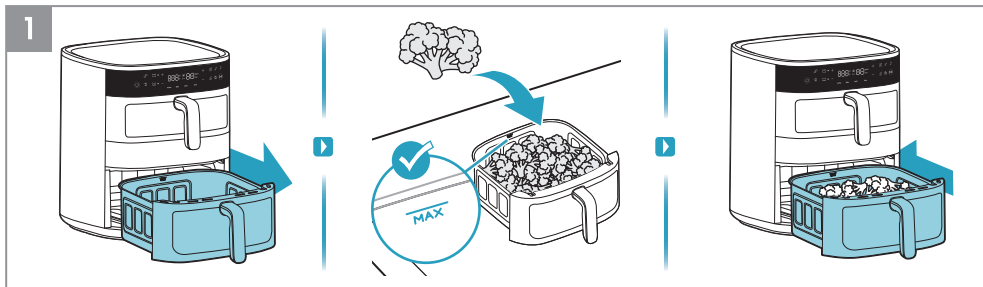

1. Вытащите одну корзину и поставьте ее на устойчивую поверхность, положите в корзину продукты, не превышая максимальную вместимость, обозначенную маркировкой "MAX.". Затем полностью задвиньте корзину с продуктами обратно в устройство.



2. Нажмите кнопку включения/выключения. Сначала выберите корзину с продуктами. Затем выберите желаемый способ приготовления, например, функцию "Air Fry" (Воздушная жарка). Настройте время и температуру по своему вкусу или выберите один из предустановленных рецептов, например, "Овощи". Наконец, нажмите кнопку "Пуск/Приостановка".

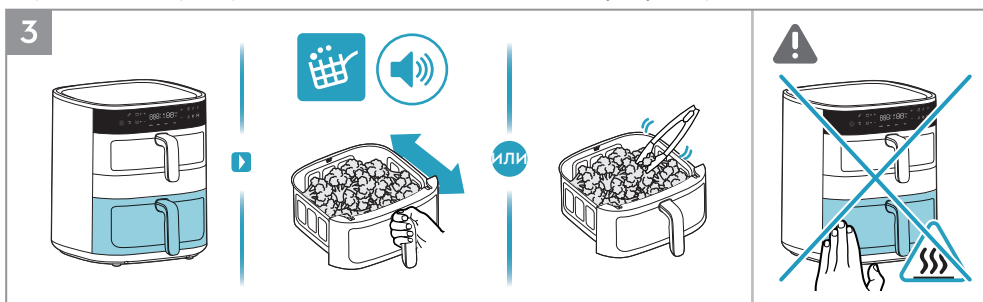

3. Когда во время приготовления загорится значок "Напоминание о перемешивании" и раздастся звуковой сигнал, переверните продукты один раз с помощью термостойких кухонных приборов или осторожно слегка встряхните корзину для жарки.

⚠ **ОСТОРОЖНО:** Не встряхивайте корзину для жарки, чтобы избежать разбрызгивания пищи и получения ожогов.

⚠ **ОСТОРОЖНО:** Будьте осторожны с горячими поверхностями, когда устройство работает.

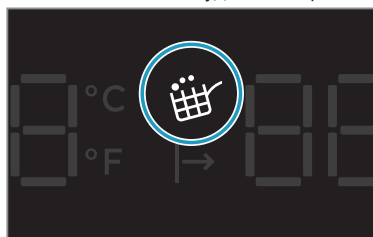

Напоминание о перемешивании

"Напоминание о перемешивании" активируется во время работы функции "Air Fry" (Воздушная жарка) и при использовании предустановленных рецептов, таких как "Овощи", "Рыба", "Куриные окорочки" и "Стейк".

Когда придет время встряхнуть или перевернуть продукты, значок "напоминания о перемешивании" загорится и будет мигать в течение одной минуты, а звуковой сигнал будет повторяться три раза.

"Напоминание о перемешивании" не является обязательным к исполнению, поэтому приготовление будет продолжаться как обычно, даже если еда не будет переворачиваться или встряхиваться.



4. По окончании времени приготовления устройство подаст звуковой сигнал. Осторожно извлеките корзину и поставьте ее на термостойкую поверхность. После использования отключите устройство от сети.

⚠ ОСТОРОЖНО: При открытии корзины в середине или в конце приготовления, из нее может выйти горячий пар. При открытии крышки держите лицо, руки и кисти рук подальше от пара.

Порядок использования - верхняя + нижняя корзина

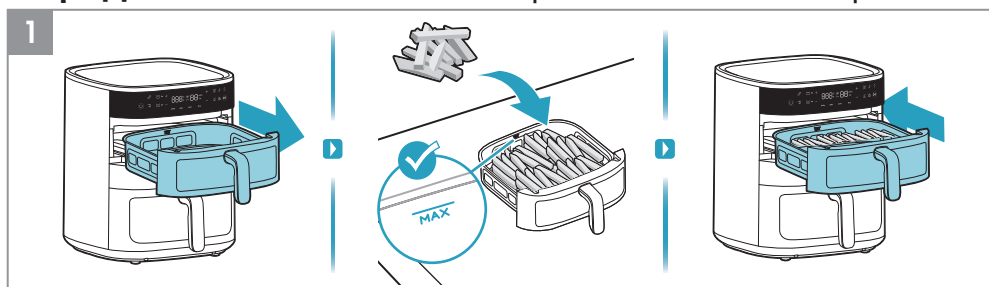

1. Сначала извлеките верхнюю корзину и положите в нее продукты, например, картофель фри.

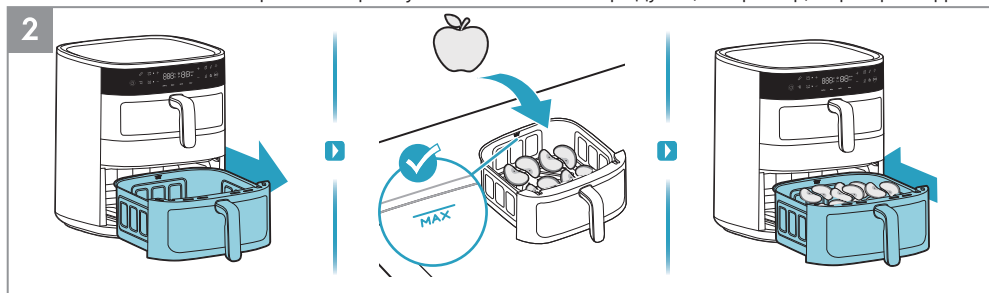

2. Затем извлеките нижнюю корзину и положите в нее продукты, например, ломтики яблок.



3. Нажмите кнопку включения/выключения. Сначала выберите верхнюю корзину. Затем выберите желаемый способ приготовления, например, функцию "Air Fry" (Воздушная жарка). Настройте время и температуру по своему вкусу или выберите один из предустановленных рецептов, например, "Овощи". Наконец, нажмите кнопку "Пуск/Приостановка".



4. Затем выберите нижнюю корзину. Затем выберите желаемый способ приготовления, например, функцию "Dry" (Сушка). Настройте время и температуру по своему вкусу. Наконец, нажмите кнопку "Пуск/Приостановка".

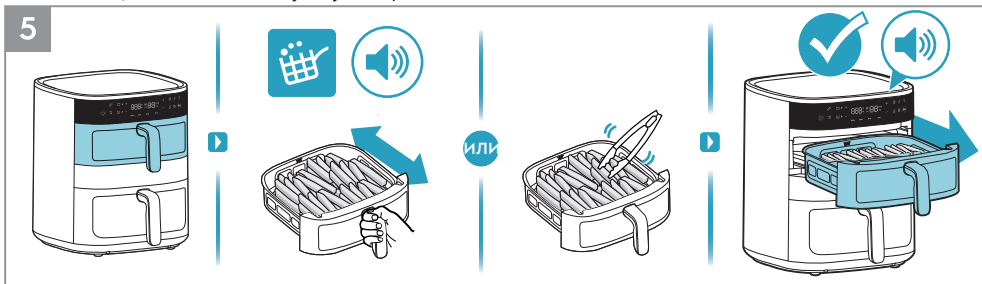

5. Когда во время приготовления загорится значок "Напоминание о перемешивании" и раздастся звуковой сигнал, переверните продукты один раз с помощью термостойких кухонных приборов или осторожно слегка встряхните корзину для жарки. По окончании времени приготовления в верхней корзине устройство подаст звуковой сигнал.

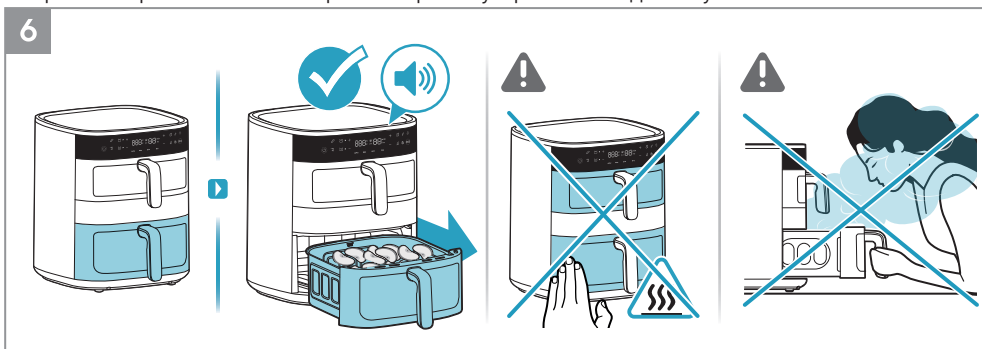

6. По окончании времени приготовления в нижней корзине прибор подаст звуковой сигнал.

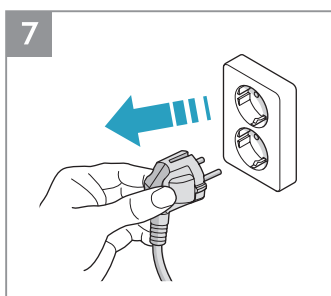

7. После использования отключите устройство от сети.

EN Порядок использования - функция сопряжения

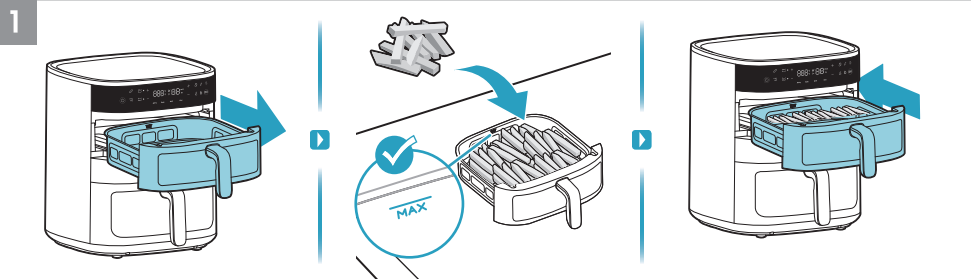

1. Сначала извлеките верхнюю корзину и положите в нее продукты, например, картофель фри.

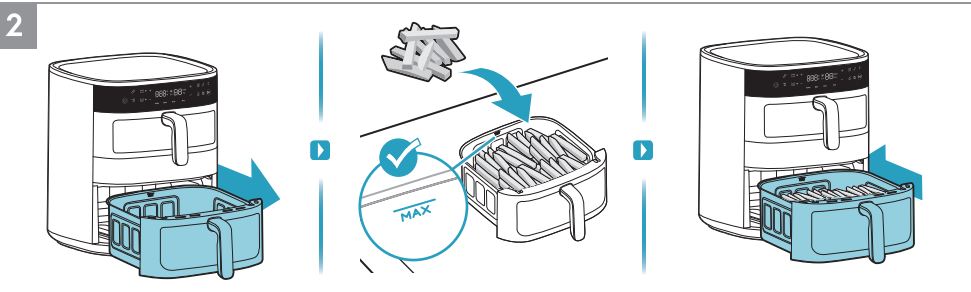

2. Затем извлеките нижнюю корзину и положите в нее продукты, например, картофель фри.

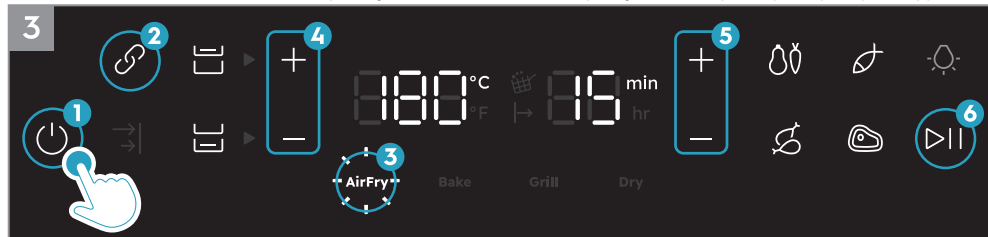

3. Нажмите кнопку включения/выключения. Сначала выберите функцию сопряжения. Затем выберите желаемый способ приготовления, например, функцию "Air Fry" (Воздушная жарка). Настройте время и температуру по своему вкусу или выберите один из предустановленных рецептов. Наконец, нажмите кнопку "Пуск/Приостановка".

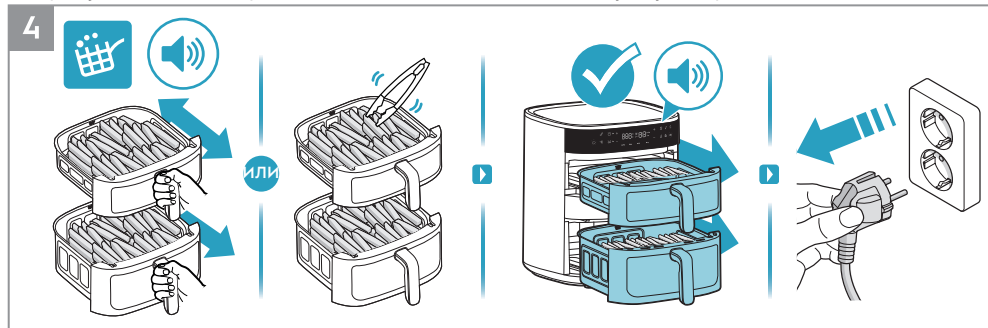

4. Когда во время приготовления загорится значок "Напоминание о перемешивании" и раздастся звуковой сигнал, переверните продукты один раз с помощью термостойких кухонных приборов или осторожно слегка встряхните корзину для жарки. По окончании времени приготовления устройство подаст звуковой сигнал. После использования отключите устройство от сети.

- BG
- CZ
- DE
- DK
- EE
- FI
- FR
- GR
- HR
- HU
- IT
- LT
- LV
- NO
- NL
- PL
- PT
- RO
- RU
- SE
- SI
- SK
- SR
- TR
- UA
- ES
- GE
- AL

Порядок использования - функция синхронизации окончания приготовления

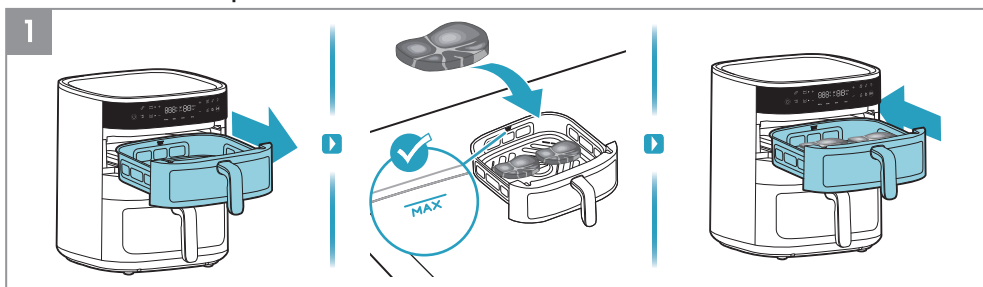

1. Сначала извлеките верхнюю корзину и положите в нее продукты, например, стейк.

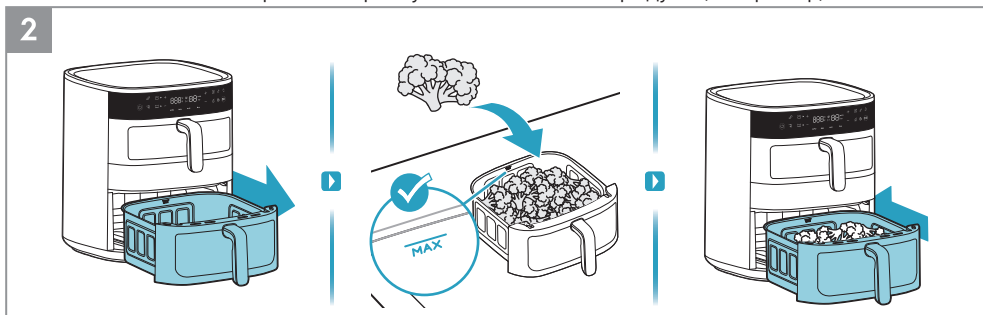

2. Затем извлеките нижнюю корзину и положите в нее продукты, например, брокколи.



3. Нажмите кнопку включения/выключения. Выберите функцию синхронизации окончания приготовления. Сначала выберите верхнюю корзину, затем выберите желаемый способ приготовления, например, функцию "Air Fry" (Воздушная жарка). Настройте время и температуру по своему вкусу или выберите один из предустановленных рецептов, например, "Стейк".



4. Затем выберите нижнюю корзину, желаемый способ приготовления, например, функцию "Air Fry" (Воздушная жарка). Настройте время и температуру по своему вкусу или выберите один из предустановленных рецептов. Наконец, нажмите кнопку "Пуск/Приостановка".

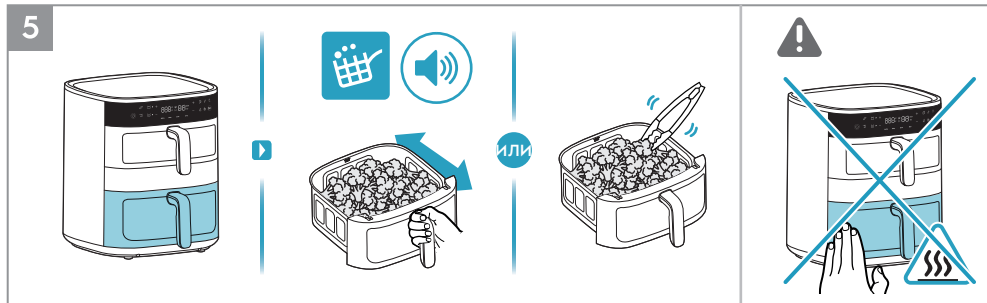

5. При этом приоритет отдается нижней корзине с более длительным временем приготовления. Когда во время приготовления загорится значок “Напоминание о перемешивании” и раздастся звуковой сигнал, переверните продукты один раз с помощью термостойких кухонных приборов или осторожно слегка встряхните корзину для жарки.

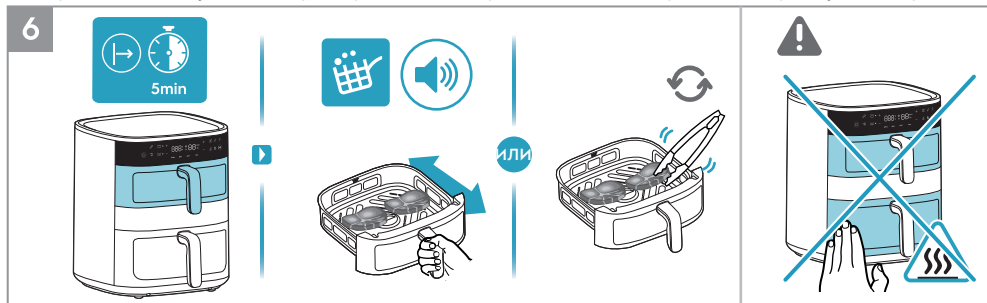

6. Затем начнется приготовление в верхней корзине с более коротким временем приготовления. Когда во время приготовления загорится значок “Напоминание о перемешивании” и раздастся звуковой сигнал, переверните продукты один раз с помощью термостойких кухонных приборов или осторожно слегка встряхните корзину для жарки.

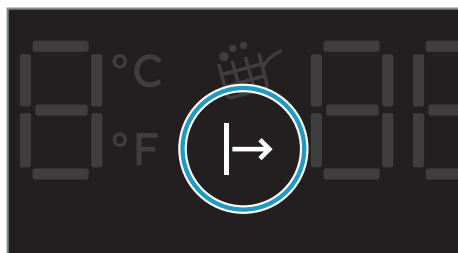

Индикатор ожидания приготовления

Когда активирована “Функция синхронизации окончания приготовления”, корзина с более коротким временем приготовления будет ждать, пока корзина с более длительным временем приготовления не проработает некоторое время, чтобы обе корзины могли закончить приготовление одновременно. В течение этого времени “индикатор ожидания приготовления” будет гореть до начала процесса приготовления.

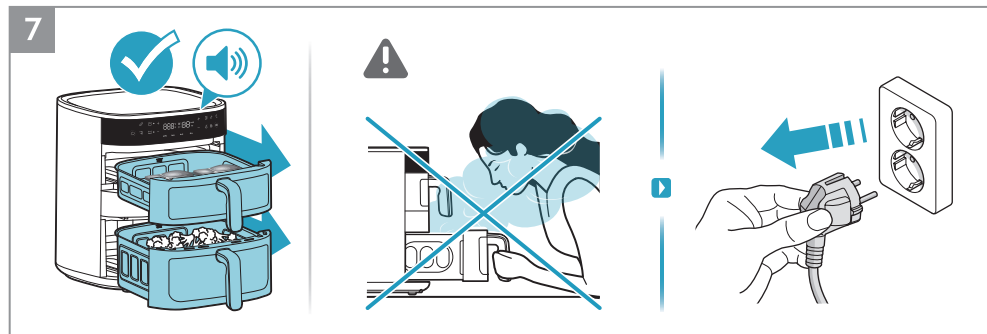

7. По окончании времени приготовления устройство подаст звуковой сигнал. После использования отключите устройство от сети.

Очистка

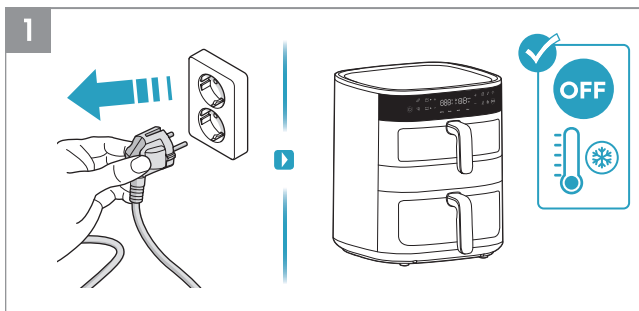

1. Перед очисткой всегда отключайте устройство от сети и дождитесь его остывания.
2. Протрите внешнюю поверхность устройства мягкой тканью.

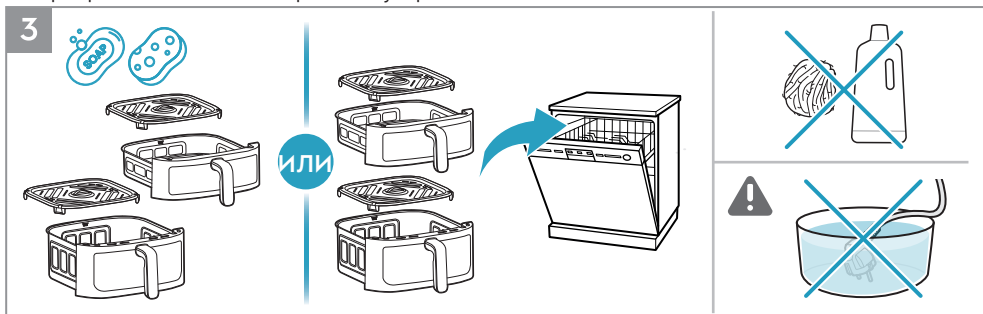
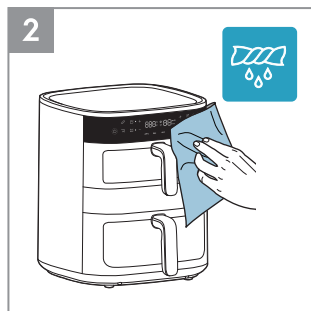

3. Вымойте корзину и решетку теплой водой с моющим средством для посуды или поместите их в посудомоечную машину.

▲ПРИМЕЧАНИЕ: Во избежание повреждения антипригарного покрытия, не используйте абразивные чистящие средства или металлические инструменты.

ОСТОРОЖНО: Никогда не погружайте устройство, его шнур или вилку в воду или любую другую жидкость.

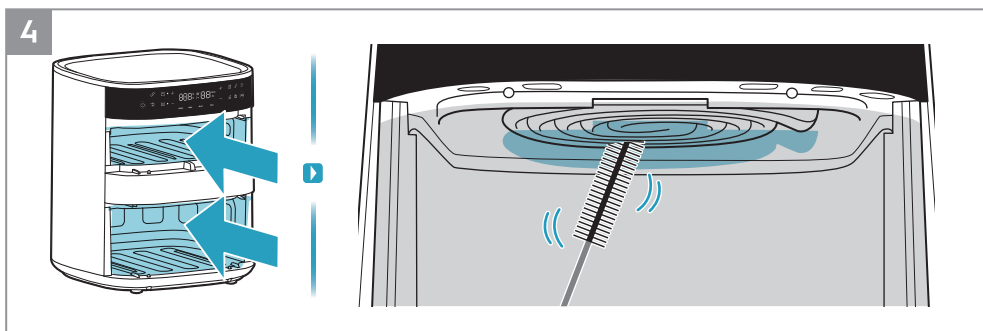











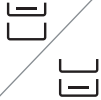







































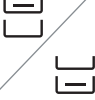











4. Очистите нагревательный элемент с помощью чистящей щетки.

ПРИМЕЧАНИЕ: Перед очисткой нагревательного элемента убедитесь, что устройство полностью остыло.

EN
BG
CZ
DE
DK
EE
FI
FR
GR
HR
HU
IT
LT
LV
NO
NL
PL
PT
RO
RU
SE
SI
SK
SR
TR
UA
ES
GE
AL

Руководство по приготовлению

								
AirFry	7mm/10mm 	 4л	400г	180°C	18мин			
		 7л	400г	180°C	18мин			
AirFry		 4л	400г	170°C	8мин			
		 7л	400г	170°C	10мин			
AirFry		 4л	400г/2шт.	140°C	15мин			
		 7л	400г/2шт.	140°C	15мин			
AirFry		 4л	1000г/8шт.	180°C	28мин			
		 7л	1000г/8шт.	180°C	28мин			
AirFry		 4л	400г/2шт.	200°C	10мин			
		 7л	400г/2шт.	200°C	10мин			
AirFry		 4л	220г/6мин	160°C	12мин			
		 7л	220г/6мин	160°C	14мин			

							
AirFry		 7л	1200г	180°C	55мин		
AirFry		 7л	400г/9шт.	160°C	20мин		
Grill		 4л	180г/4шт.	180°C	8мин		
		 7л	180г/4шт.	180°C	9мин		
Dry		 4л	180г	80°C	3часа		
		 7л	180г	80°C	3часа		
Dry		 4л	200г	80°C	3часа		
		 7л	200г	80°C	3часа		

- EN
- BG
- CZ
- DE
- DK
- EE
- FI
- FR
- GR
- HR
- HU
- IT
- LT
- LV
- NO
- NL
- PL
- PT
- RO
- RU**
- SE
- SI
- SK
- SR
- TR
- UA
- ES
- GE
- AL

Что делать, если...

Проблема	Проверьте, что...
Вы не можете включить или использовать устройство.	<ul style="list-style-type: none"> • Устройство правильно подключено к источнику электропитания. • Корзины находятся в правильном положении. Убедитесь, что они полностью вставлены в устройство, чтобы обеспечить подачу электропитания. • Время приготовления установлено.
Вы не можете вставить корзину в устройство.	<ul style="list-style-type: none"> • Корзина заполнена сверх максимальной вместимости. • Корзина установлена правильно. Она должна защелкнуться, когда вы помещаете ее в устройство. • Под корзиной находится предмет, который мешает ее закрыть должным образом.
Из устройства выходит белый дым.	<ul style="list-style-type: none"> • Пища, которую вы готовите, слишком жирная. • Корзина, решетка и нагревательный элемент чистые.
На дисплее отображается E1	• Обрыв цепи верхней корзины.
На дисплее отображается E2	• Короткое замыкание цепи верхней корзины.
На дисплее отображается E3	• Обрыв цепи нижней корзины.
На дисплее отображается E4	• Короткое замыкание цепи нижней корзины.
На дисплее отображается E5	• Ошибка связи платы управления.
На дисплее отображается E6	• Ошибка связи платы питания.

* Если на дисплее отображаются коды ошибок, устройство необходимо отремонтировать в сервисном центре.

Технические данные

Изделие	Аэрофритюрница
Модель	EAFD11B
Напряжение (В пер. тока)	220-240 В
Мощность (Вт)	2700 Вт
Частота (Гц)	50 ~ 60 Hz
Вместимость	4 л + 7 л



Instruktionsbok

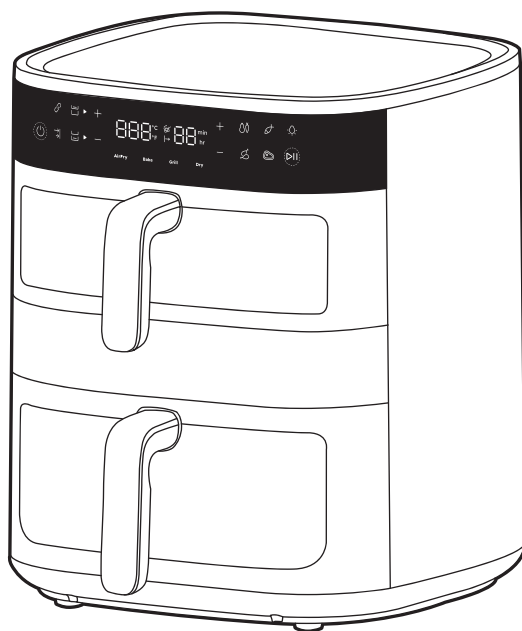

800 Dubbel Varmluftsfritös

Allmän Översikt

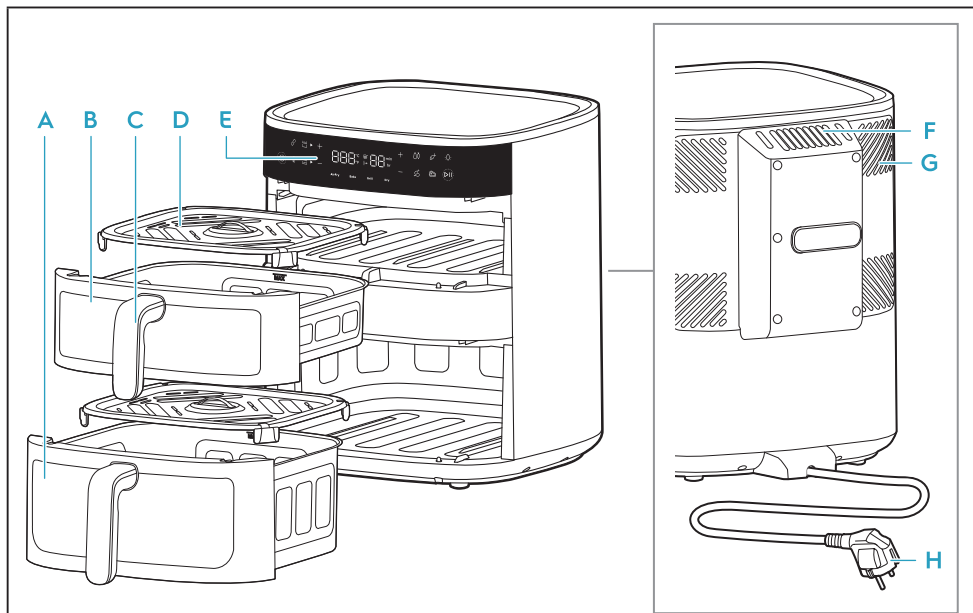

- A** Nedre korg (7L)
- B** Övre korg (4L)
- C** Korghandtag
- D** Galler
- E** Kontrollpanel
- F** Luftutlopp
- G** Kylsystem
- H** Huvudsladd

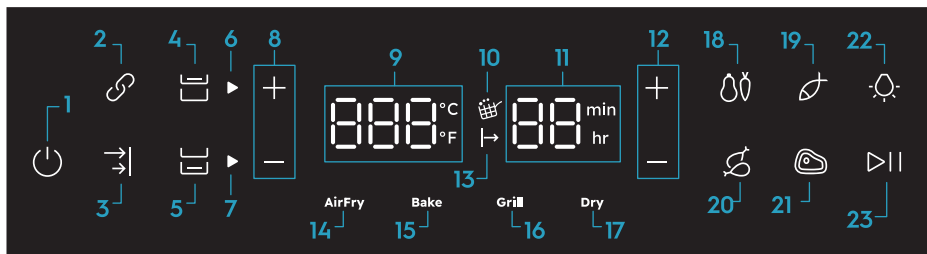

- 1. På/Av
- 2. Länkfunktion
- 3. Funktion för Synchroniserat Slut
- 4. Kontroll övre korg
- 5. Kontroll nedre korg
- 6. Indikator övre korg
- 7. Indikator nedre korg
- 8. Temperaturreglage
- 9. Temperaturindikator (40-200°C)
- 10. Skakningspåminnelse
- 11. Tidsindikator (AirFry: 1-99 min, Dehydrera: 1-5h)
- 12. Tidsreglage
- 13. Väntar på tillagning
- 14. AirFry-funktion
- 15. Bakfunktion
- 16. Grillfunktion
- 17. Torkfunktion
- 18. Grönsaker
- 19. Fisk
- 20. Kyckling
- 21. Stek
- 22. Ljusstyrning
- 23. Start/Paus

Innan första användning

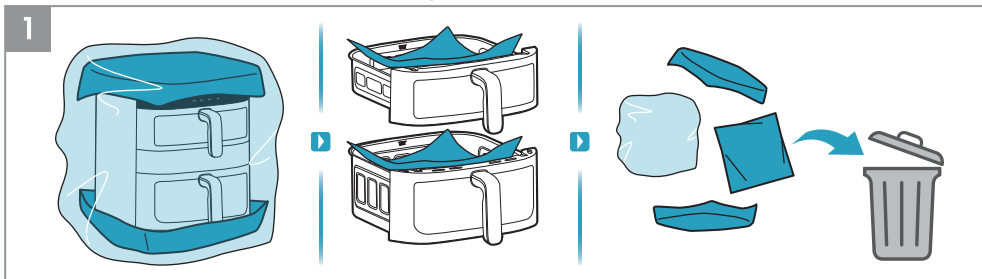

1. Ta bort alla förpackningar och skyddsmaterial.

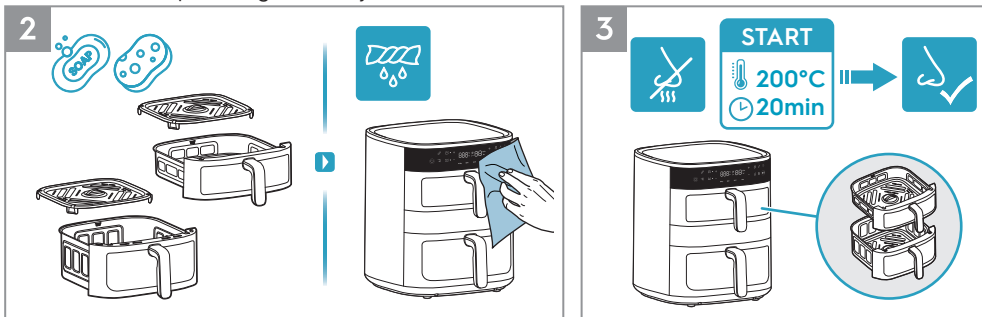



2. Rengör pannan och gallret med varmt vatten och diskmedel. Torka av insidan och utsidan av apparaten med en mjuk trasa.

3. Det är normalt att en ny enhet avger lukt de första gångerna den används. Kör den tomma varmluftsritösen på 200 °C i 20 minuter före första användning för att undvika det.

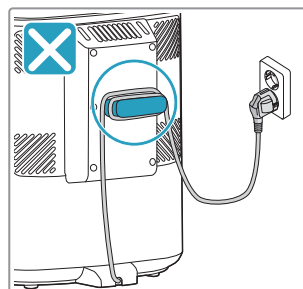
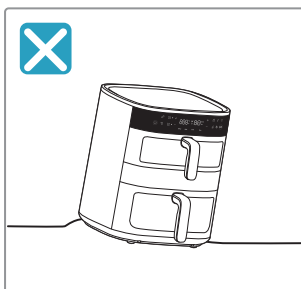
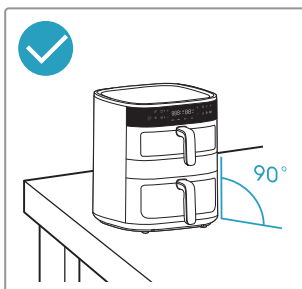
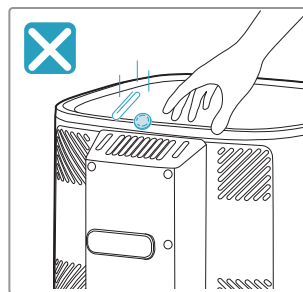
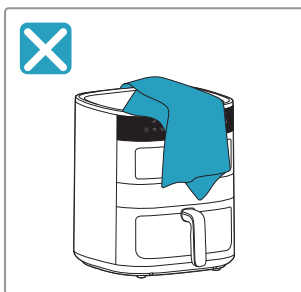
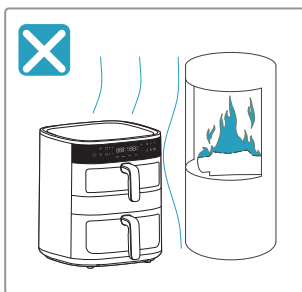



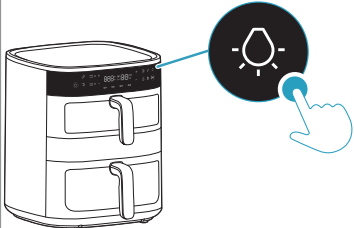
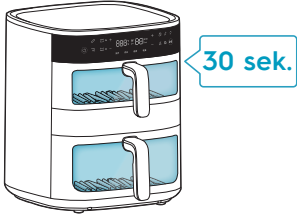

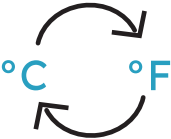







! Säkerhetsföreskrifter









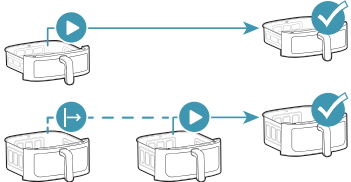







Ljusstyrning & omvandling av temperaturskala

<p>Ljusstyrning</p> 		
<p>°C/°F Omvandling av temperaturskala</p>		

Val av korg

	 <p>4L</p>	 <p>7L</p>	
<p>Övre Korg</p> 			
<p>Nedre Korg</p> 			
<p>Länkfunktion</p> 			
<p>Funktion för Synkroniserat Slut</p> 			

Förinställda Funktioner

					
AirFry	180°C	15min	60-200°C	1-99min	
	170°C	10min	60-200°C	1-99min	
	140°C	15min	60-200°C	1-99min	
	180°C	30min	60-200°C	1-99min	
	200°C	10min	60-200°C	1-99min	
Bake	170°C	15min	60-200°C	1-99min	
Grill	200°C	5min	60-200°C	1-99min	
Dry	80°C	5tim	40-80°C	1-5tim	

Innan tillagning

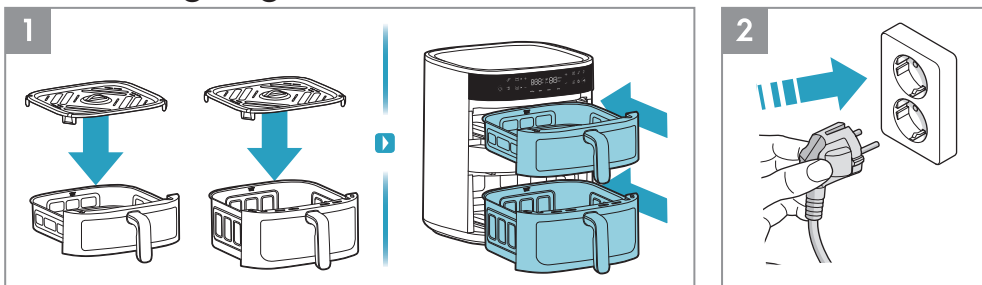

1. Före varje tillagning placerar du gallret i korgen (den värmebeständiga silikonfotplattan på gallret behöver inte tas bort) och tryck in korgen helt i apparaten.
2. Sätt i strömkontakten i vägguttaget.

Användning - En korg

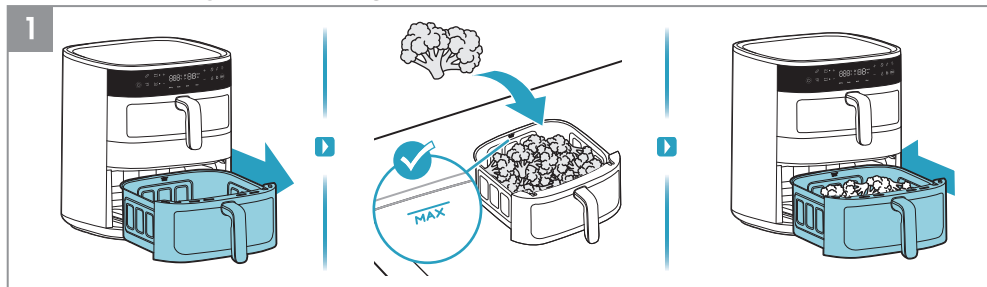

1. Dra ut en korg och placera den på ett stabilt underlag, lägg maten i korgen och ta kapacitetsmarkeringen "MAX." i beaktande. Tryck sedan helt tillbaka korgen med mat in i apparaten.

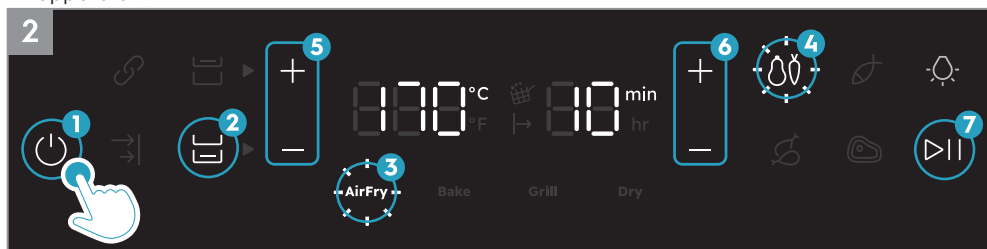

2. Tryck på På/Av-knappen. Välj först korgen med mat. Välj sedan önskad matlagningsmetod, till exempel Air Fry-funktion. Justera tid och temperatur efter smak eller välj ett av de förinställda recepten, till exempel Grönsak. Tryck till sist på knappen Start/Paus.

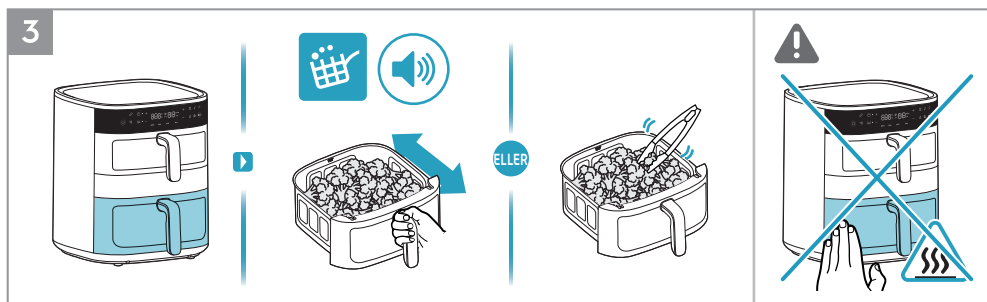

3. När ikonen "Skakningspåminnelse" tänds och piper under tillagningsprocessen använder du värmebeständiga verktyg för att vända maten en gång eller skaka maten försiktigt i stekkorgen lite.

⚠ **FÖRSIKTIGHET:** Skaka inte stekkorgen kraftigt för att undvika matstänk och brännskador.

⚠ **FÖRSIKTIGHET:** Var försiktig med heta ytor när apparaten används.

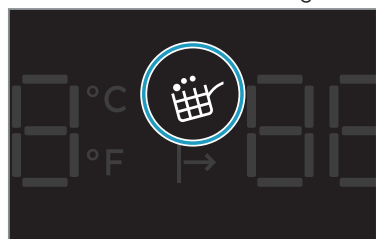

Skakningspåminnelse

"Skakningspåminnelse" aktiveras vid Air Fry-funktionen och för de förinställda recepten, såsom Grönsaker, Fisk, Kycklinglår och Stek.

När det är dags att skaka eller vända på maten tänds ikonen "Skakningspåminnelse" som blinkar i en minut medan ett pip ljud upprepas tre gånger.

"Skakningspåminnelsen" är inte obligatorisk, och därför kommer tillagningen att fortsätta som vanligt även om maten inte vänds eller skakas.

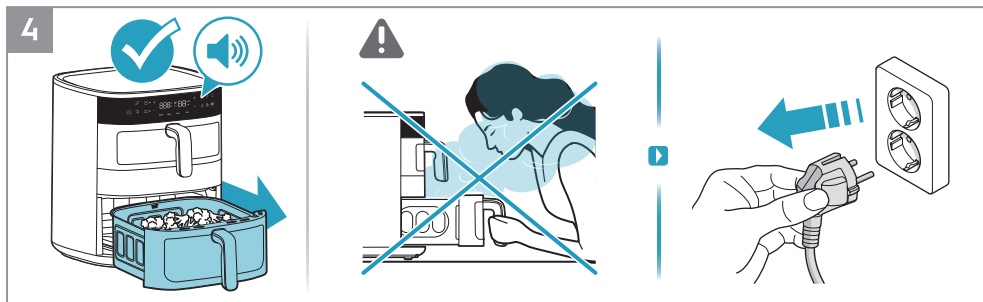

4. I slutet av tillagningstiden kommer apparaten att avge en pipsignal. Ta försiktigt bort korgen och placera den på ett värmebeständigt underlag. Koppla ur apparaten efter användning.

⚠ **FÖRSIKTIGHET:** Varm ånga kan komma ut ur korgen när den öppnas under eller i slutet av tillagningen. Se till att hålla ansikte, armar och händer borta från ångan när du öppnar den.

Användning - Övre + nedre korg

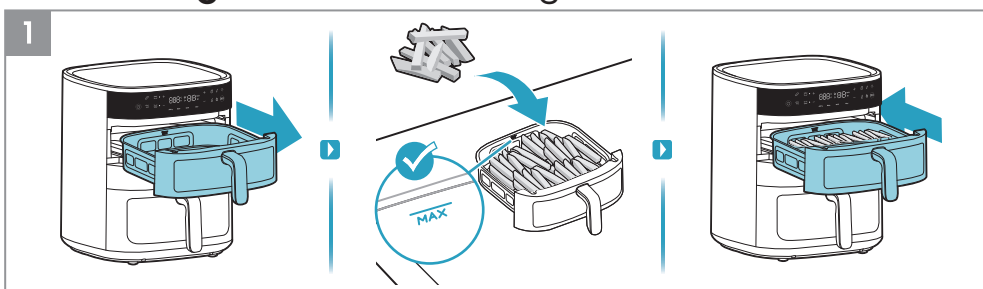

1. Dra först ut den övre korgen och lägg maten i korgen, till exempel pommes frites.

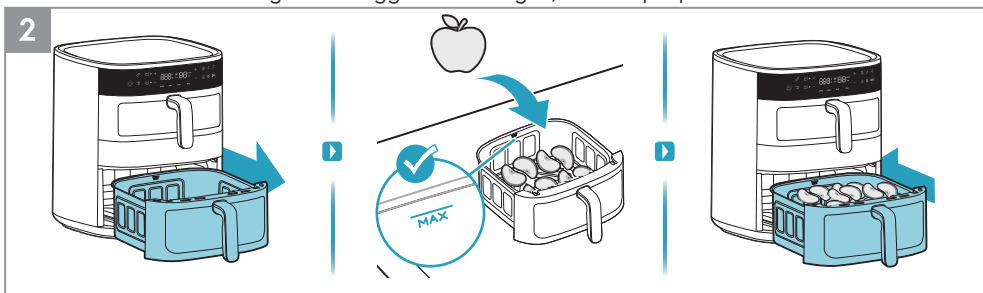

2. Dra sedan ut den nedre korgen och lägg maten i korgen, till exempel äppelskivor.



3. Tryck på På/Av-knappen. Välj först den övre korgen. Välj sedan önskad matlagningsmetod, till exempel Air Fry-funktion. Justera tid och temperatur efter smak eller välj ett av de förinställda recepten, till exempel Grönsak. Tryck till sist på knappen Start/Paus.



4. Välj härnäst den nedre korgen. Välj sedan önskad tillagningsmetod, till exempel Torkfunktion. Justera tid och temperatur efter smak. Tryck till sist på knappen Start/Paus.

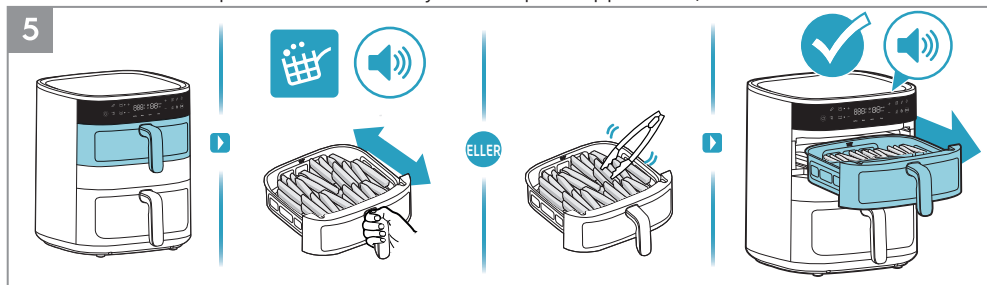

5. När ikonen "Skakningspåminnelse" tänds och piper under tillagningsprocessen använder du värmebeständiga verktyg för att vända maten en gång eller skaka maten försiktigt i stekkorgen lite. I slutet av den övre korgens tillagningstid kommer apparaten att avge en pipsignal.

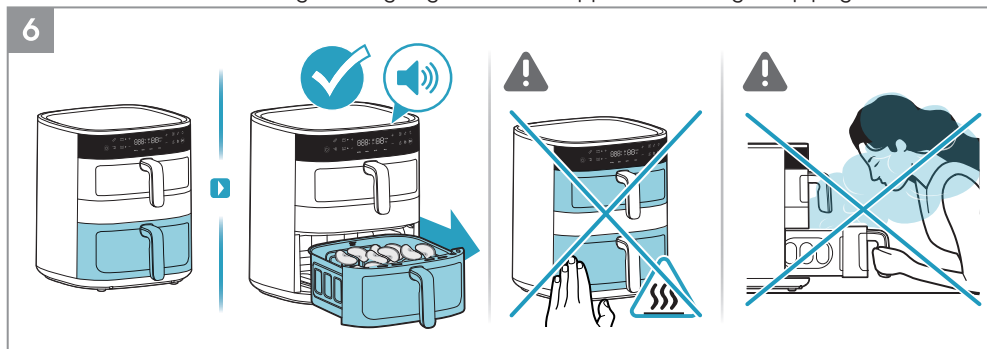

6. I slutet av den nedre korgens tillagningstid kommer apparaten att avge en pipsignal.

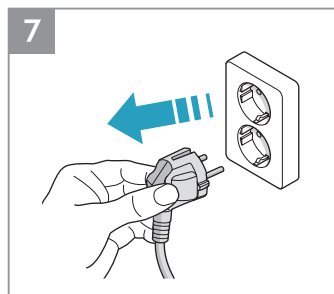

7. Koppla ur apparaten efter användning.

Användning - Länkfunktion

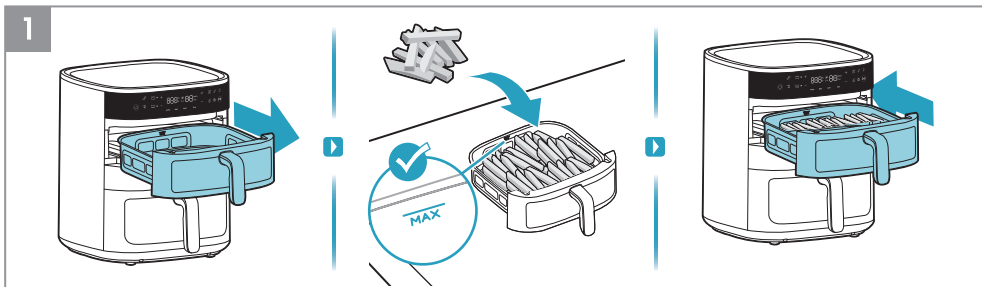

1. Dra först ut den övre korgen och lägg maten i korgen, till exempel pommes frites.

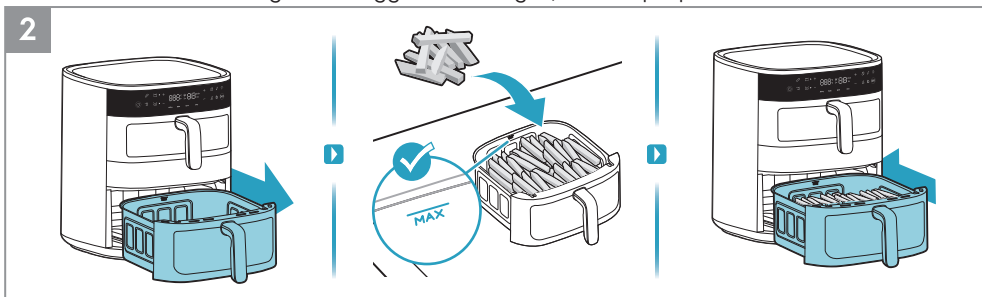

2. Dra sedan ut den nedre korgen och lägg maten i korgen, till exempel pommes frites.



3. Tryck på På/Av-knappen. Välj först länkfunktionen. Välj sedan önskad matlagningsmetod, till exempel Air Fry-funktion. Justera tid och temperatur efter smak eller välj ett av de förinställda recepten. Tryck till sist på knappen Start/Paus.

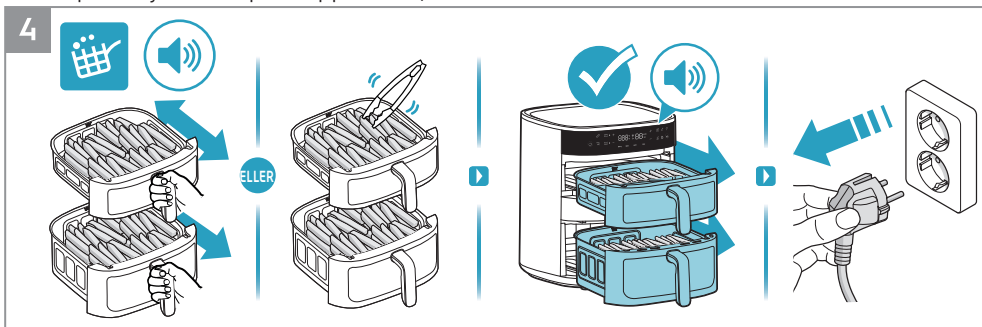

4. När ikonen "Skakningspåminnelse" tänds och piper under tillagningsprocessen använder du värmebeständiga verktyg för att vända maten en gång eller skaka maten försiktigt i stekkorgen lite. I slutet av tillagningstiden kommer apparaten att avge en pipsignal. Koppla ur apparaten efter användning.

EN
BG
CZ
DE
DK
EE
FI
FR
GR
HR
HU
IT
LT
LV
NO
NL
PL
PT
RO
RU
SE
SI
SK
SR
TR
UA
ES
GE
AL

Användning - Funktion för Synkroniserat Slut

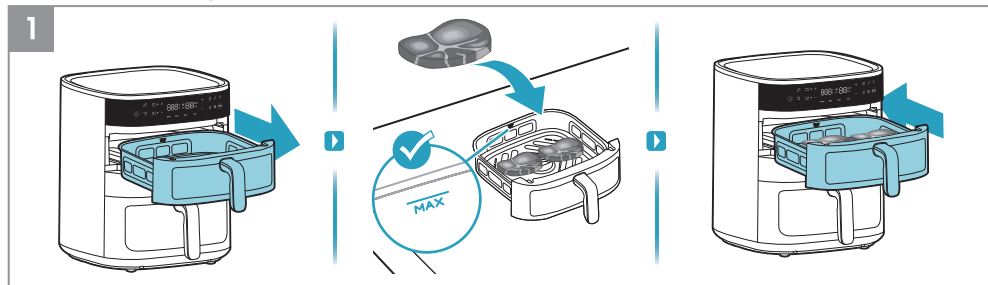

1. Dra först ut den övre korgen och lägg maten i korgen, till exempel en stek.

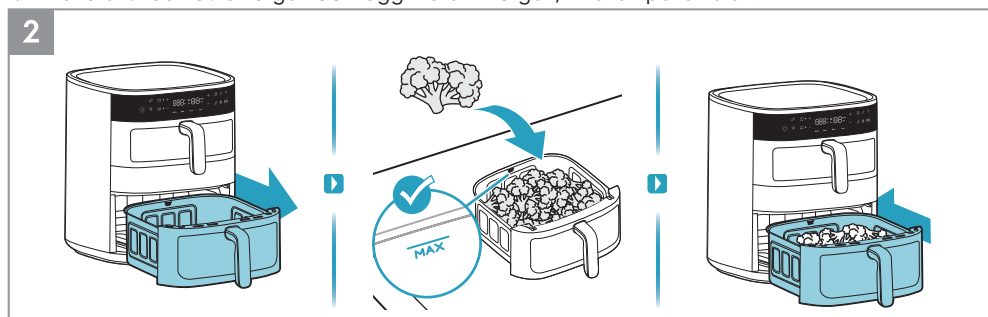

2. Dra sedan ut den nedre korgen och lägg maten i korgen, till exempel broccoli.



3. Tryck på På/Av-knappen. Välj funktionen för Synkroniserat Slut. Välj först den övre korgen och välj sedan önskad tillagningsmetod, till exempel Air Fry-funktion. Justera tid och temperatur efter smak eller välj ett av de förinställda recepten, till exempel Stek.



4. Välj sedan den nedre korgen och välj önskad tillagningsmetod, till exempel Air Fry-funktion. Justera tid och temperatur efter smak eller välj ett av de förinställda recepten. Tryck till sist på knappen Start/Paus.

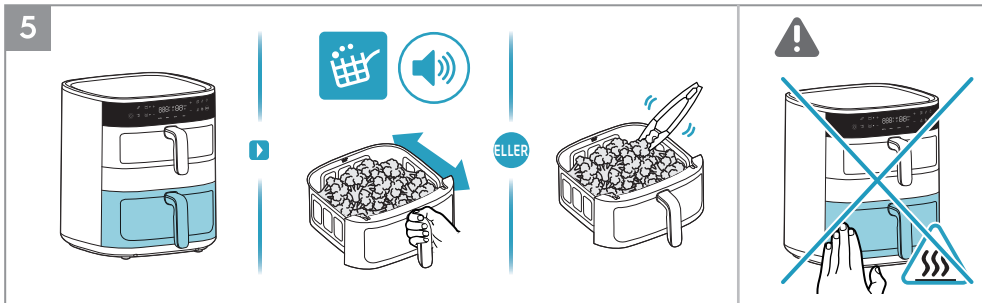

5. Först kommer den nedre korgen med längre inställd tid att prioriteras för tillagning. När ikonen "Skakningspåminnelse" tänds och piper under tillagningsprocessen använder du värmebeständiga verktyg för att vända maten en gång eller skaka maten försiktigt i stekkorgen lite.

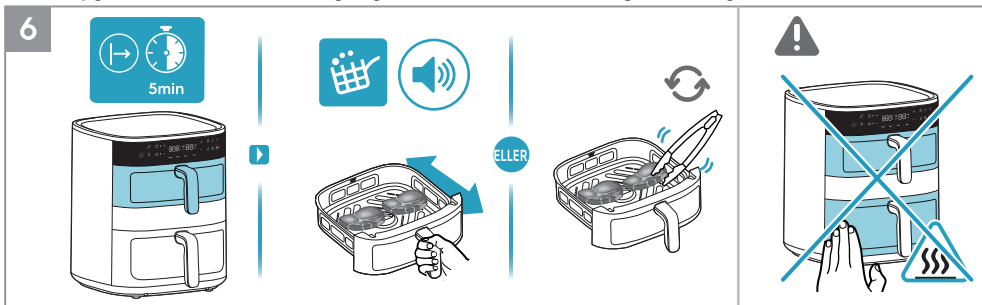

6. Sedan kommer den övre korgen med kortare inställd tid att påbörja tillagning. När ikonen "Skakningspåminnelse" tänds och piper under tillagningsprocessen använder du värmebeständiga verktyg för att vända maten en gång eller skaka maten försiktigt i stekkorgen lite.

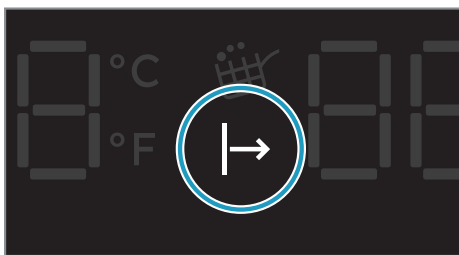

"Väntar på tillagning"-indikator

När "Funktion för Synkroniserat Slut" är aktiverad kommer korgen med kortare tillagningstid att vänta på tillagning tills korgen med längre tillagningstid tillagats ett tag, så att båda korgarna kan avsluta tillagningen samtidigt. Under denna period lyser "Väntar på tillagning"-indikatorn tills tillagningen börjar.

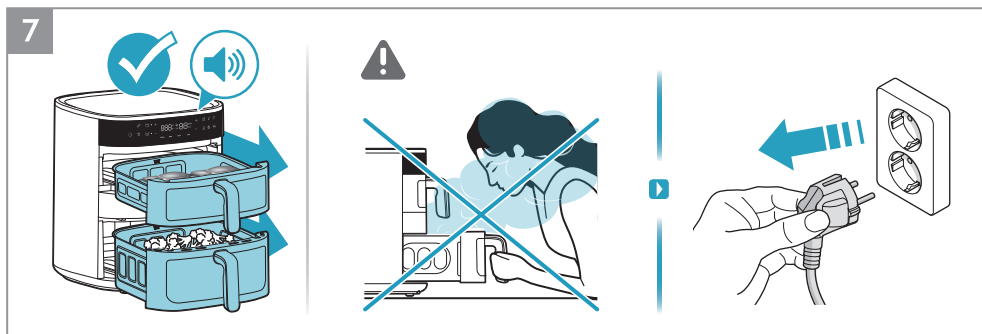

7. I slutet av tillagningstiden kommer apparaten att avge en pipsignal. Koppla ur apparaten efter användning.

Rengöring

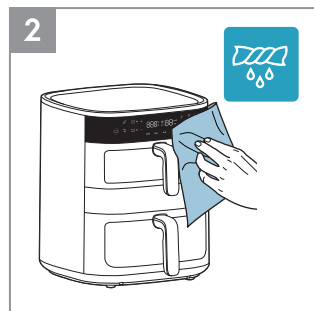
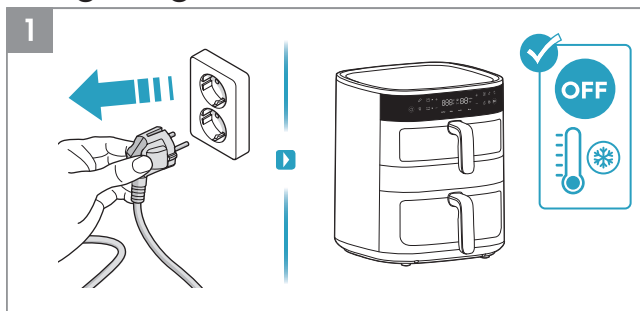

1. Koppla alltid ur apparaten och vänta tills den har svalnat innan du rengör den.
2. Torka av utsidan av apparaten med en mjuk trasa.

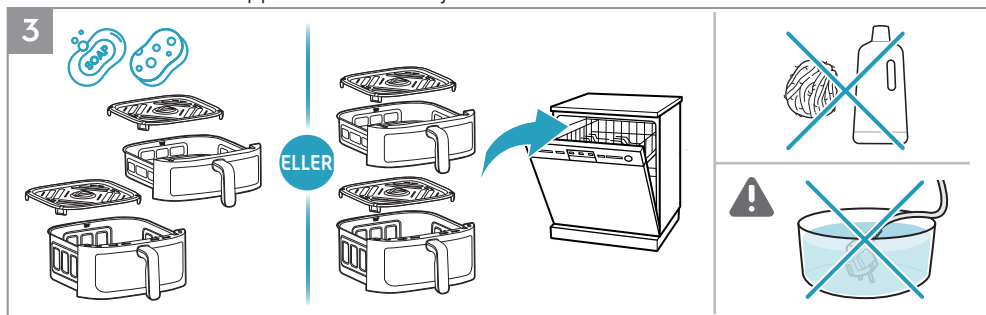



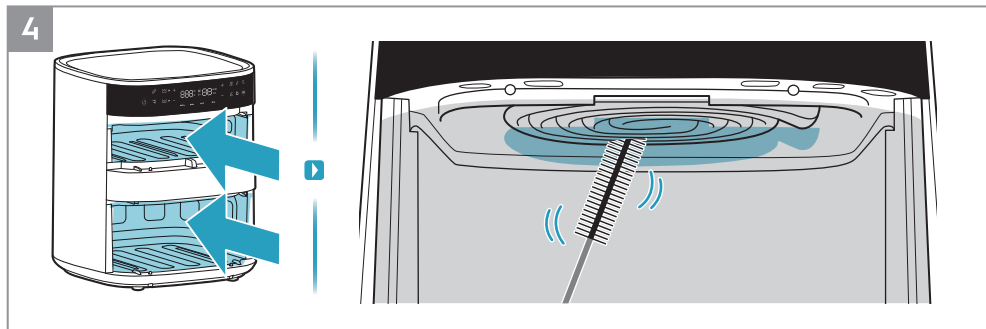







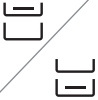



























3. Rengör pannan och gallret med varmt vatten och diskmedel, eller placera dem i diskmaskinen.
- ⚠OBSERVERA:** Undvik att använda slipande rengöringsprodukter eller metallverktyg för att skydda non-stick-beläggningen.
- FÖRSIKTIGHET:** Sänk aldrig ner produkten, sladden eller kontakten i vatten eller annan vätska.















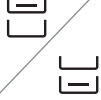













4. Rengör värmeelementet med en rengöringsborste.
- OBSERVERA:** Se till att apparaten är helt sval innan du rengör värmeelementet.

Tillagningsguide

							
AirFry	7mm/10mm 	4L 	400g	180°C	18min		
		7L 	400g	180°C	18min		
AirFry		4L 	400g	170°C	8min		
		7L 	400g	170°C	10min		
AirFry		4L 	400g/2st	140°C	15min		
		7L 	400g/2st	140°C	15min		
AirFry		4L 	1000g/8st	180°C	28min		
		7L 	1000g/8st	180°C	28min		
AirFry		4L 	400g/2st	200°C	10min		
		7L 	400g/2st	200°C	10min		
AirFry		4L 	220g/6cm	160°C	12min		
		7L 	220g/6cm	160°C	14min		

- EN
- BG
- CZ
- DE
- DK
- EE
- FI
- FR
- GR
- HR
- HU
- IT
- LT
- LV
- NO
- NL
- PL
- PT
- RO
- RU
- SE**
- SI
- SK
- SR
- TR
- UA
- ES
- GE
- AL

EN
BG
CZ
DE
DK
EE
FI
FR
HR
GR
HU
IT
LT
LV
NO
NL
PL
PT
RO
RU
SE
SI
SK
SR
TR
UA
ES
GE
AL

							
AirFry		7L 	1200g	180°C	55min		
AirFry		7L 	400g/9st	160°C	20min		
Grill		4L 	180g/4st	180°C	8min		
Grill		7L 	180g/4st	180°C	9min		
Dry		4L 	180g	80°C	3tim		
Dry		7L 	180g	80°C	3tim		
Dry		4L 	200g	80°C	3tim		
Dry		7L 	200g	80°C	3tim		

Vad man ska göra om...

Problem	Kontrollera om...
Du inte kan starta eller använda apparaten.	<ul style="list-style-type: none">• Apparaten är korrekt ansluten till ett eluttag.• Korgarna är i rätt position. Se till att de är helt inskjutna i apparaten för att möjliggöra strömförsörjningen.• Tillagningstiden är inställd.
Du inte kan skjuta in korgen i apparaten.	<ul style="list-style-type: none">• Korgen är fylld över sin maxgräns.• Korgen är korrekt placerad. Det måste klicka när du sätter in den i enheten.• Det finns ett föremål under korgen som hindrar den från att stängas ordentligt.
Det kommer ut vit rök ur apparaten.	<ul style="list-style-type: none">• Maten du lagar är för fet.• Korgen, gallret och värmeelementet är rena.
Bildskärmen visar E1	<ul style="list-style-type: none">• Övre korg öppen krets.
Bildskärmen visar E2	<ul style="list-style-type: none">• Övre korg kortsluten.
Bildskärmen visar E3	<ul style="list-style-type: none">• Nedre korg öppen krets.
Bildskärmen visar E4	<ul style="list-style-type: none">• Nedre korg kortsluten.
Bildskärmen visar E5	<ul style="list-style-type: none">• Kommunikationsfel PCBA-styrkort.
Bildskärmen visar E6	<ul style="list-style-type: none">• Kommunikationsfel Power PCBA.

* Om displayen visar felkoder måste apparaten repareras av ett servicecenter.

Tekniska data

Produkt	Varmluftsfritös
Modell	EAFD11B
Spänning (V~)	220 V ~ 240 V
Effekt (W)	2700 W
Frekvens (Hz)	50 ~ 60 Hz
Kapacitet	4 L + 7 L



Navodila za uporabo

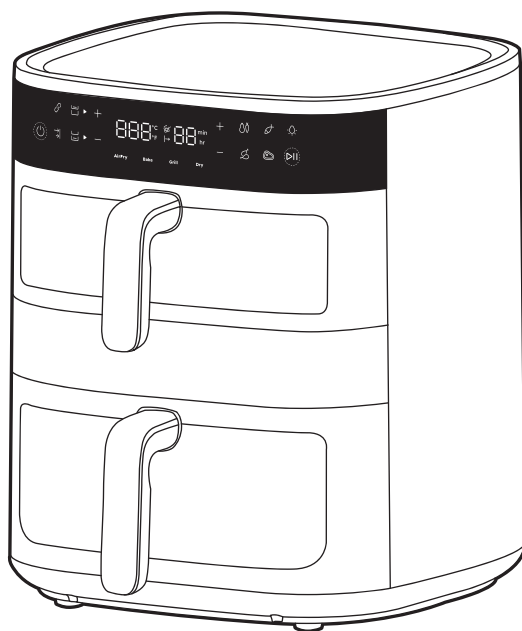

800 dvojni cvrtnik na vroč zrak

Splošni pregled

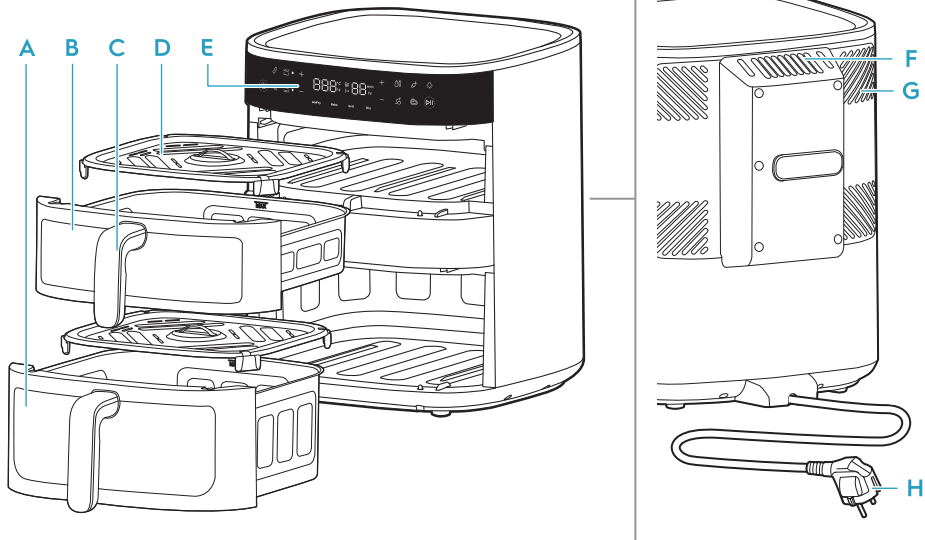

- | | | | |
|-------------------------------|-----------------------|-----------------------------|--------------------------|
| A Spodnja košara (7 l) | C Ročaj košare | E Upravljalna plošča | G Hladilni sistem |
| B Zgornja košara (4 l) | D Rešetka | F Izhod za zrak | H Glavni kabel |

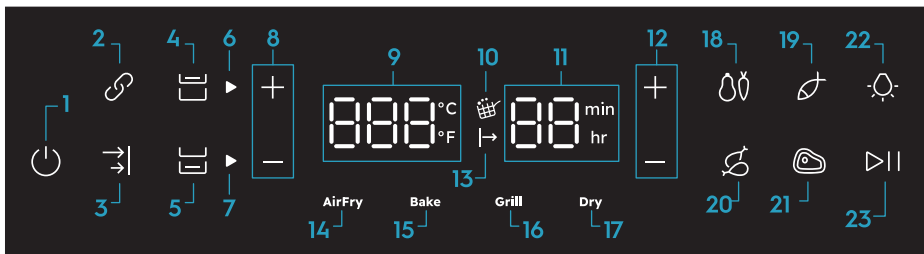

- | | | | |
|---|--|----------------------------------|----------------------|
| 1. Vklp/izklop | 8. Upravljanje temperature | 12. Upravljanje časa | 18. Zelenjava |
| 2. Funkcija povezave | 9. Kontrolna lučka temperature (40–200 °C) | 13. Čakanje na kuhanje | 19. Ribe |
| 3. Funkcija sinhronizacije konca | 10. Opomnik za stresanje | 14. Funkcija cvrtja na vroč zrak | 20. Piščanec |
| 4. Upravljanje zgornje košare | 11. Kontrolna lučka (Cvrtnik na vroč zrak: 1–99 min, dehidracija: 1–5 h) | 15. Funkcija peke | 21. Zrezek |
| 5. Upravljanje spodnje košare | | 16. Funkcija žara | 22. Upravljanje luči |
| 6. Kontrolna lučka zgornje košare | | 17. Funkcija sušenja | 23. Predvajaj/premor |
| 7. Kontrolna lučka spodnje košare indicator | | | |

Pred prvo uporabo

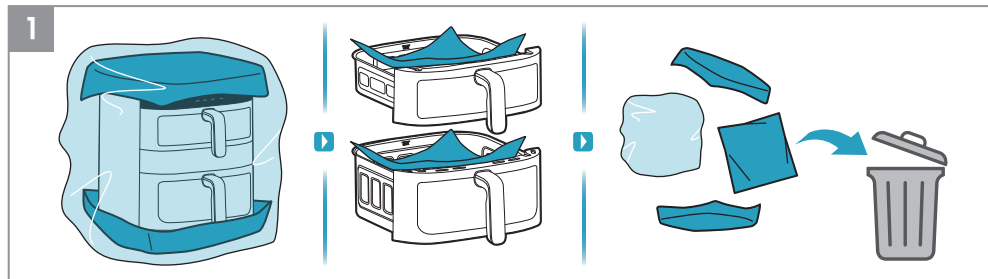

1. Odstranite vso embalažo in zaščitni material.

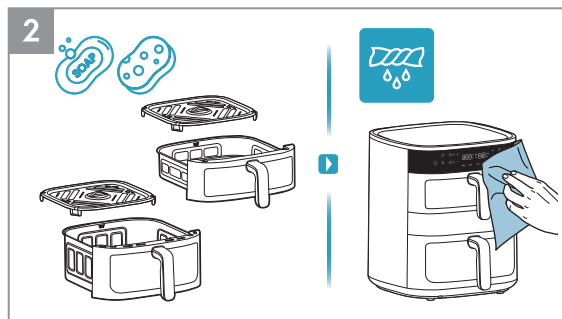

2. Ponev in rešetko očistite s toplo vodo in detergentom za pomivanje posode. Napravo obrišite z mehko krpo znotraj in zunaj.

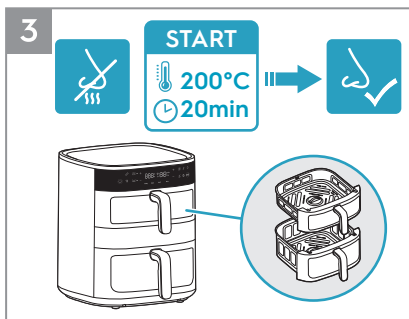

3. Povsem normalno je, da nova naprava ob prvih nekaj uporabah oddaja vonjave. Da bi se temu izognili, pred prvo uporabo prazen cvrtnik na vroč zrak za 20 minut zaženite pri 200 °C.



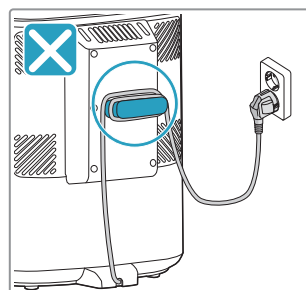
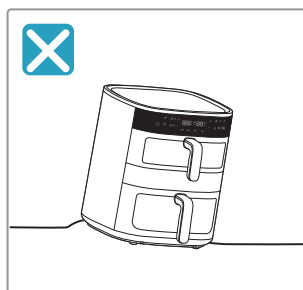
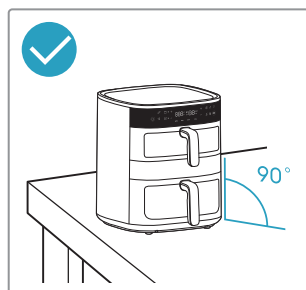
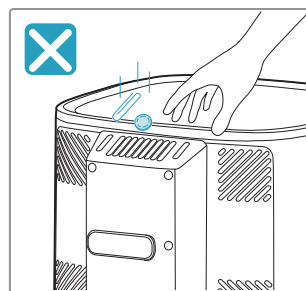
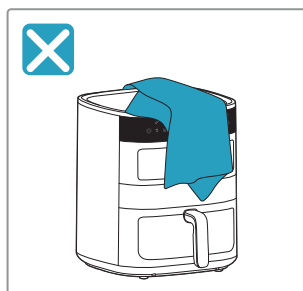



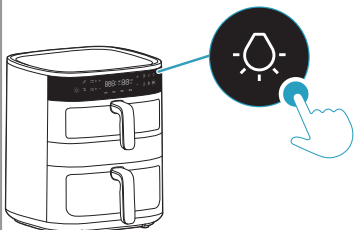
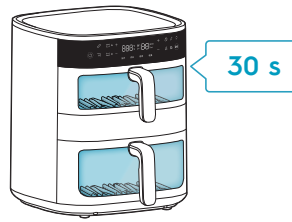
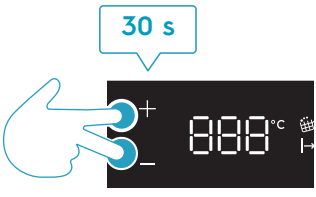
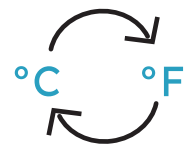



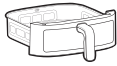

! Varnostni ukrepi



Upravljanje luči in pretvorba temperaturne lestvice





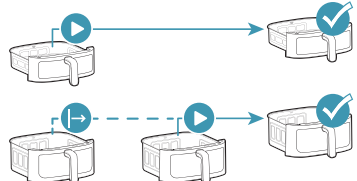





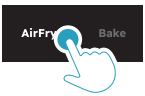



 <p>Upravljanje luči</p>		
<p>°C/°F</p> <p>Pretvorba temperaturne lestvice</p>		

Izbira košare

	 <p>4L</p>	 <p>7L</p>	
 <p>Zgornja košara</p>			
 <p>Spodnja košara</p>			
 <p>Funkcija povezave</p>			
 <p>Funkcija sinhronizacije konca</p>			

- EN
- BG
- CZ
- DE
- DK
- EE
- FI
- FR
- GR
- HR
- HU
- IT
- LT
- LV
- NO
- NL
- PL
- PT
- RO
- RU
- SE
- SI**
- SK
- SR
- TR
- UA
- ES
- GE
- AL

Prednastavljene funkcije

					
Air Fry	180°C	15min	60-200°C	1-99min	
	170°C	10min	60-200°C	1-99min	
	140°C	15min	60-200°C	1-99min	
	180°C	30min	60-200°C	1-99min	
	200°C	10min	60-200°C	1-99min	
Bake	170°C	15min	60-200°C	1-99min	
Grill	200°C	5min	60-200°C	1-99min	
Dry	80°C	5h	40-80°C	1-5h	

Pred kuhanjem

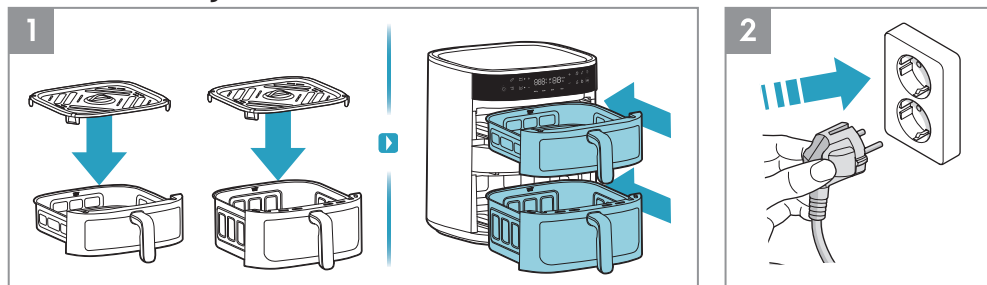

1. Pred vsakim kuhanjem položite rešetko v košaro (toplotno odporne silikonske podporne nogice na rešetki ni treba odstraniti) in košaro v celoti potisnite v napravo.
2. Vstavite napajalni vtič v vtičnico.

Kako uporabljati – enojna košara

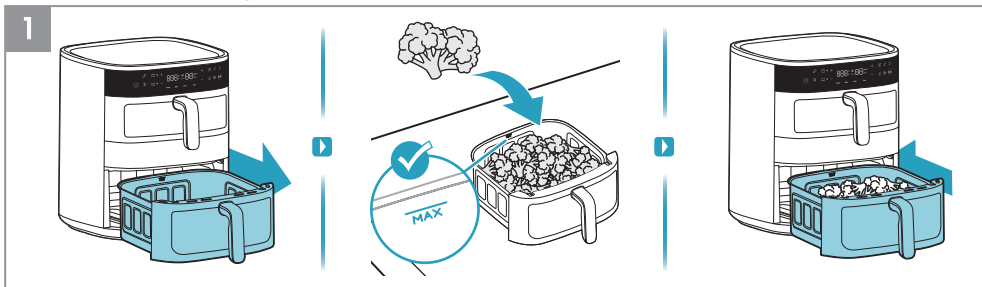

1. Izvlecite eno košaro in jo postavite na stabilno površino, hrano položite v košaro, pri čemer pazite na oznako kapacitete "MAX". Nato košaro s hrano v celoti potisnite nazaj v napravo.



2. Pritisnite gumb za vklop/izklop. Najprej izberite košaro s hrano. Nato izberite zeleni način kuhanja, na primer funkcijo cvrtja na vročem zraku. Prilagodite čas in temperaturo po svojem okusu ali izberite enega od prednastavljenih receptov, na primer Zelenjava. Na koncu pritisnite gumb za predvajanje/premor.

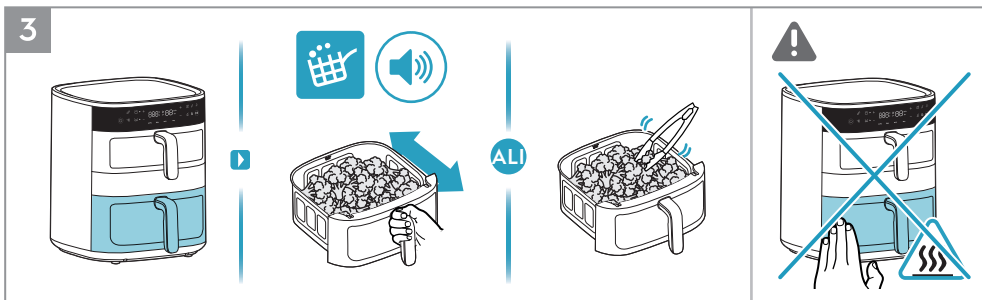

3. Ko se med postopkom kuhanja prižge simbol "Opomnik za stresanje" in se oglasi pisk, uporabite orodja, odporna na vročino, da enkrat obrnete hrano ali previdno nekoliko pretresete hrano v košari za cvrtje.

⚠ **OPOZORILO:** ne tresite košare za cvrtje sunkovito, da preprečite škropljenje hrane in povzročitev opeklin.

⚠ **OPOZORILO:** Bodite previdni pri vročih površinah med uporabo naprave.

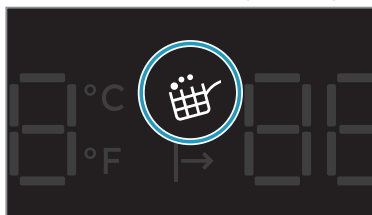

Opomnik za stresanje

"Opomnik za stresanje" je aktiviran med funkcijo cvrtja na vročem zraku in prednastavljenimi recepti, kot so zelenjava, ribe, piščančje peruti in zrezek.

Ko je čas za stresanje ali obračanje vaše hrane, se bo simbol »Opomnik za stresanje« prižgal in utripal eno minuto, medtem ko se bo pisk ponovil trikrat.

»Opomnik za stresanje« ni obvezen, zato se bo kuhanje nadaljevalo kot običajno, tudi če hrana ne bo obrnjena ali pretresena.



4. Ob koncu časa kuhanja bo naprava zapiskala. Previdno odstranite košaro in jo postavite na površino, odporno na vročino. Po uporabi napravo odklopite iz vtičnice.

⚠ **OPOZORILO:** ko se košara med kuhanjem ali na koncu odpre, lahko iz nje izstopi vroča para. Zagotovite, da boste med odpiranjem košare obraz, roke in dlani držali stran od pare.

Kako uporabljati – zgornja in spodnja košara

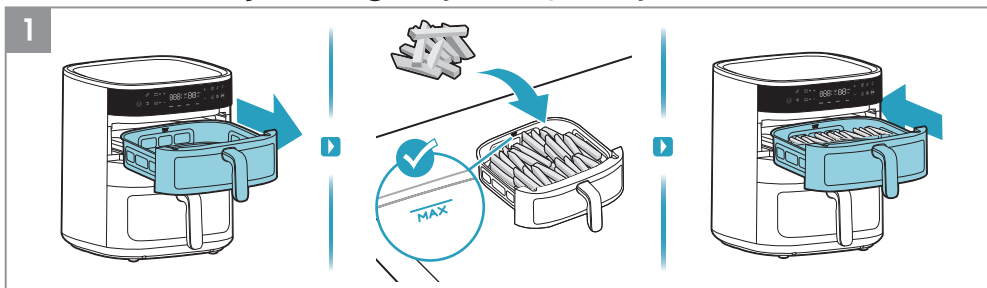

1. Najprej izvlecite zgornjo košaro in vanjo dajte hrano, na primer ocvrt krompirček.

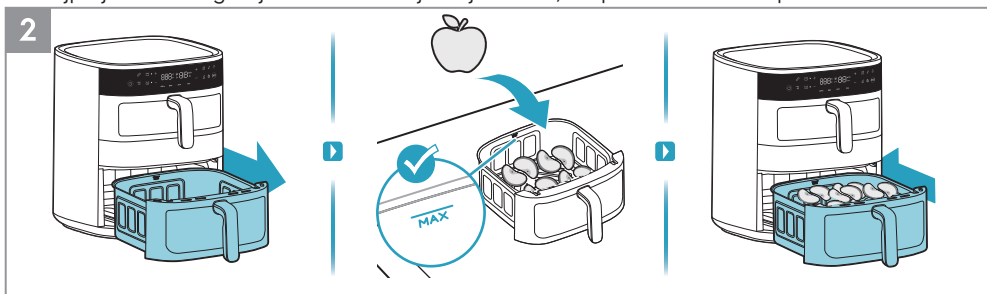

2. Nato izvlecite spodnjo košaro in vanjo dajte hrano, na primer rezine jabolk.



3. Pritisnite gumb za vklop/izklop. Najprej izberite zgornjo košaro. Nato izberite zeleni način kuhanja, na primer funkcijo cvrtja na vročem zraku. Prilagodite čas in temperaturo po svojem okusu ali izberite enega od prednastavljenih receptov, na primer Zelenjava. Na koncu pritisnite gumb za predvajanje/premor.



4. Nato izberite spodnjo košaro. Nato izberite želeni način kuhanja, na primer funkcijo sušenja. Prilagodite čas in temperaturo po svojem okusu. Na koncu pritisnite gumb za predvajanje/premor.

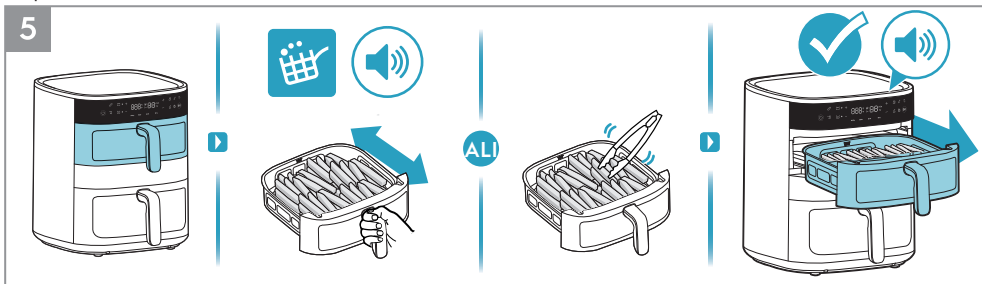

5. Ko se med postopkom kuhanja prižge simbol "Opomnik za stresanje" in se oglasi pisk, uporabite orodja, odporna na vročino, da enkrat obrnete hrano ali previdno nekoliko pretresete hrano v košari za cvrtje. Ob koncu časa kuhanja zgornje košare bo naprava zapiskala.

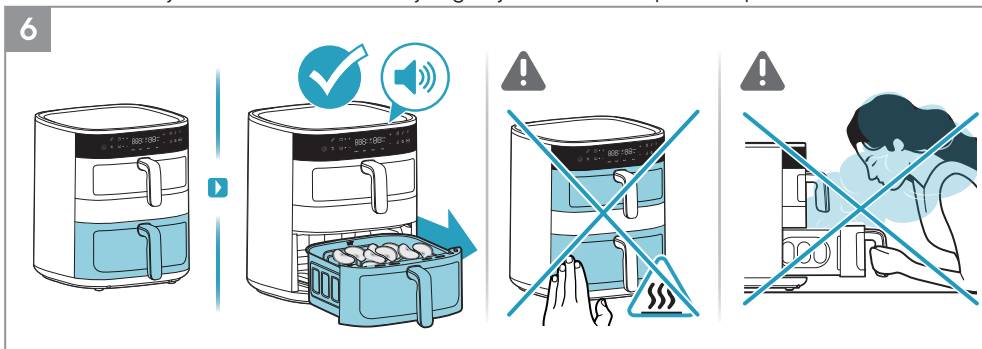

6. Ob koncu časa spodnje košare bo naprava zapiskala.

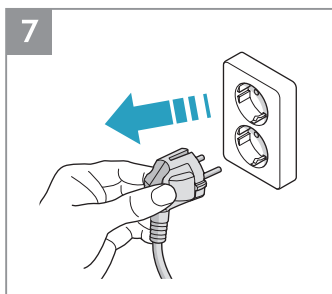

7. Po uporabi napravo odklopite iz vtičnice.

EN
BG
CZ
DE
DK
EE
FI
FR
GR
HR
HU
IT
LT
LV
NO
NL
PL
PT
RO
RU
SE
SI
SK
SR
TR
UA
ES
GE
AL

Kako uporabljati – funkcija povezave

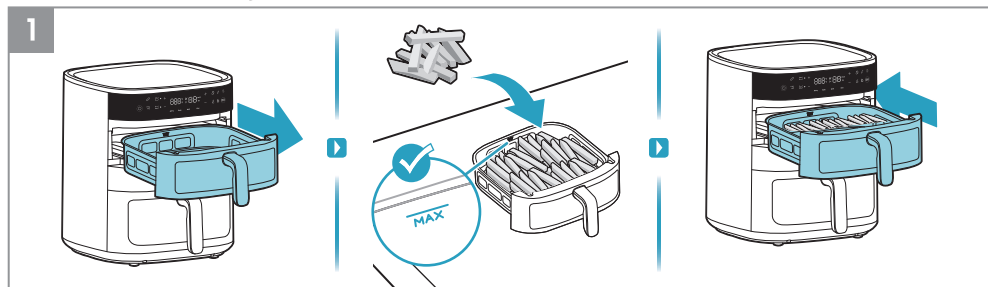

1. Najprej izvalcite zgornjo košaro in vanjo dajte hrano, na primer ocvrt krompirček.

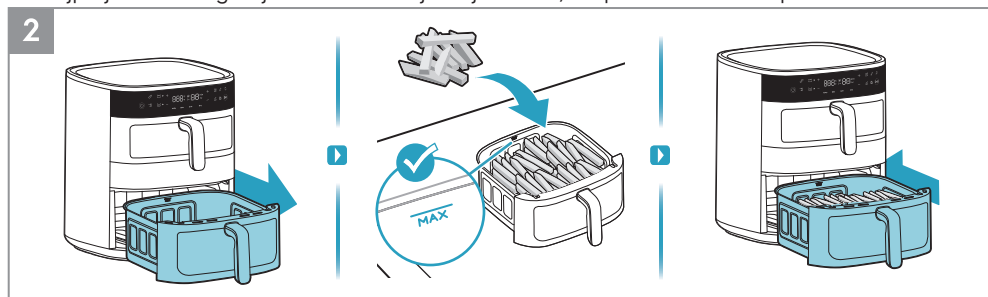

2. Nato izvalcite spodnjo košaro in vanjo dajte hrano, na primer ocvrt krompirček.



3. Pritisnite gumb za vklop/izklop. Najprej izberite funkcijo povezave. Nato izberite zeleni način kuhanja, na primer funkcijo cvrtja na vročem zraku. Prilagodite čas in temperaturo po svojem okusu ali izberite enega od prednastavljenih receptov. Na koncu pritisnite gumb za predvajanje/premor.

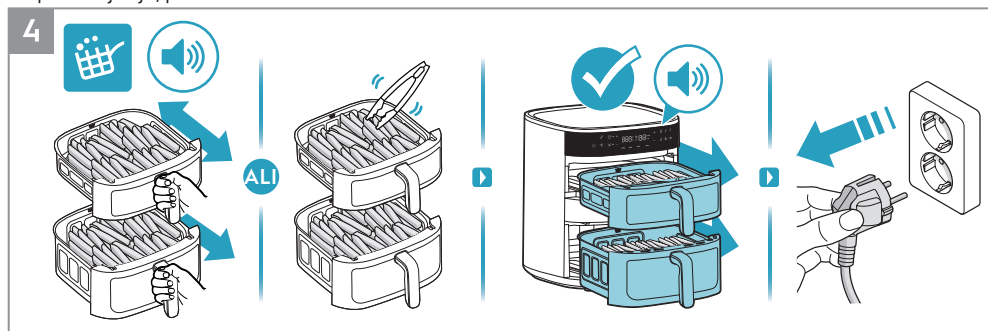

4. Ko se med postopkom kuhanja prižge simbol "Opomnik za stresanje" in se oglasi pisk, uporabite orodja, odporna na vročino, da enkrat obrnete hrano ali previdno nekoliko pretresete hrano v košari za cvrtje. Ob koncu časa kuhanja bo naprava zapiskala. Po uporabi napravo odklopite iz vtičnice.

Kako uporabljati – funkcija sinhronizacije konca

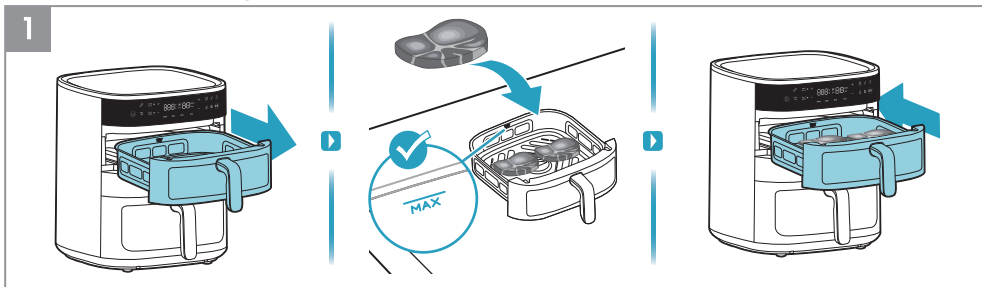

1. Najprej izvlecite zgornjo košaro in vanjo dajte hrano, na primer zrezek.

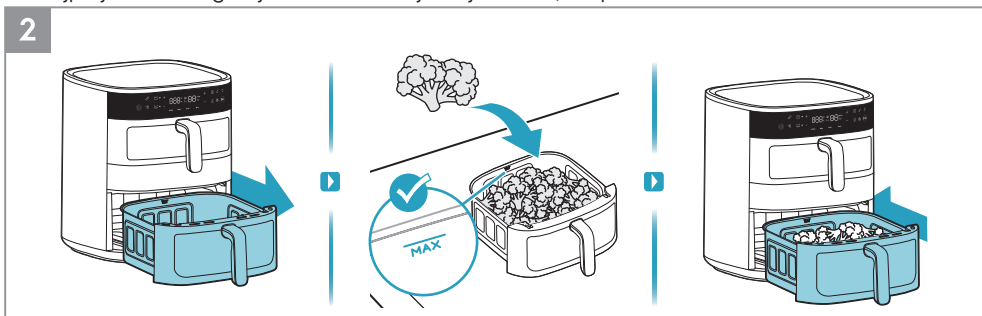

2. Nato izvlecite spodnjo košaro in vanjo dajte hrano, na primer brokoli.



3. Pritisnite gumb za vklop/izklop. Izberite funkcijo sinhronizacije konca. Najprej izberite zgornjo košaro. Nato izberite želeni način kuhanja, na primer funkcijo cvrtja na vročem zraku. Prilagodite čas in temperaturo po svojem okusu ali izberite enega od prednastavljenih receptov, na primer zrezek.

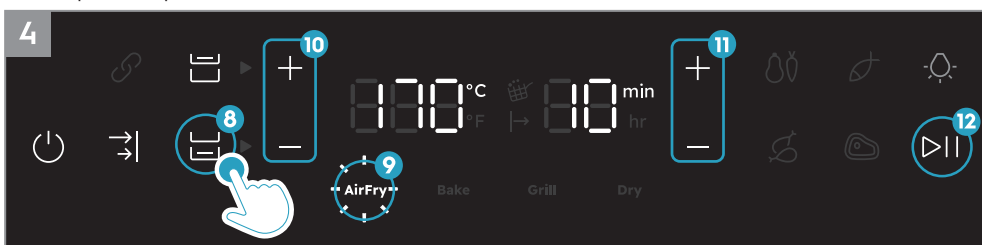

4. Nato izberite spodnjo košaro. Izberite želeni način kuhanja, na primer funkcijo cvrtja na vročem zraku. Prilagodite čas in temperaturo po svojem okusu ali izberite enega od prednastavljenih receptov. Na koncu pritisnite gumb za predvajanje/premor.

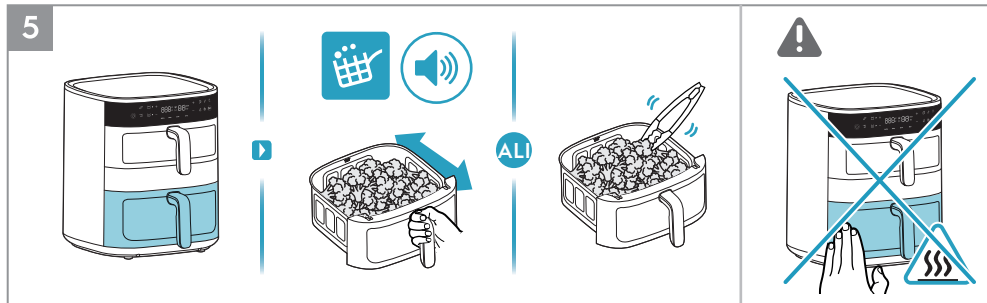

5. Najprej se bo prednostno začelo kuhanje v spodnji košari z daljšim nastavljenim časom. Ko se med postopkom kuhanja prižge simbol "Opomnik za stresanje" in se oglasi pisk, uporabite orodja, odporna na vročino, da enkrat obrnete hrano ali previdno nekoliko pretresete hrano v košari za cvrtje.

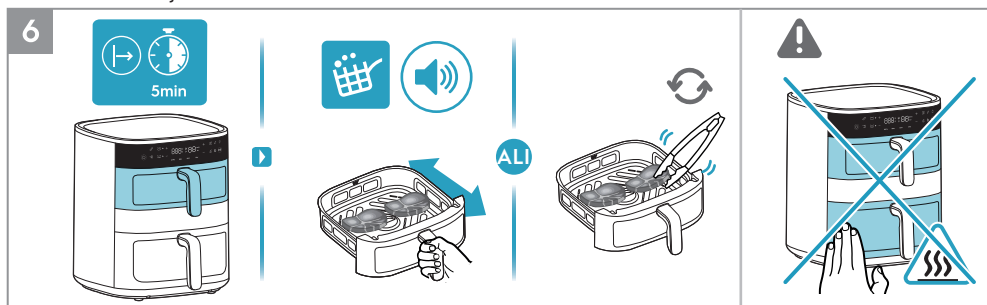

6. Nato se bo kuhanje začelo v zgornji košari s krajšim nastavljenim časom. Ko se med postopkom kuhanja prižge simbol "Opomnik za stresanje" in se oglasi pisk, uporabite orodja, odporna na vročino, da enkrat obrnete hrano ali previdno nekoliko pretresete hrano v košari za cvrtje.

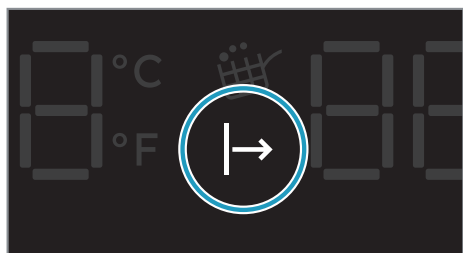

Kontrolna lučka čakanja na kuhanje

Ko je aktivirana "funkcija sinhronizacije konca", bo košara s krajšim časom kuhanja čakala na kuhanje, dokler košara z daljšim časom kuhanja ne bo kuhala nekaj časa, tako da bosta obe košari končali kuhanje hkrati. V tem obdobju bo "kontrolna lučka čakanja na kuhanje" svetila, dokler se kuhanje ne začne.

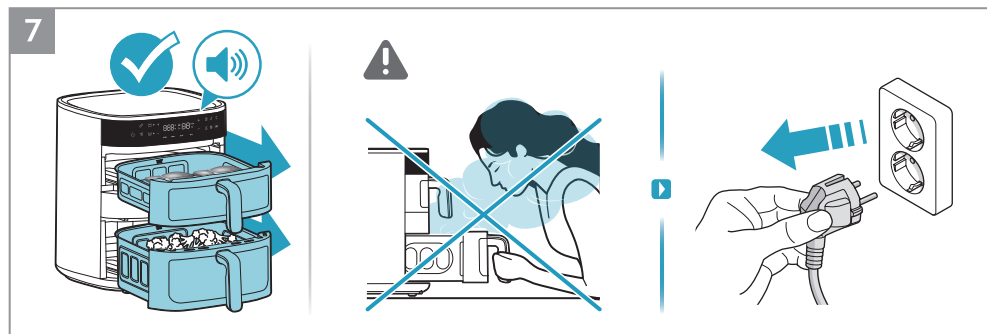

7. Ob koncu časa kuhanja bo naprava zapiskala. Po uporabi napravo odklopite iz vtičnice.

Čiščenje

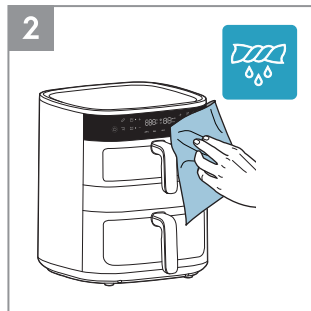
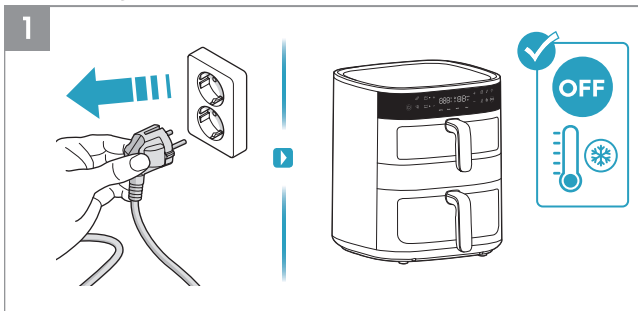

1. Pred čiščenjem vedno odklopite napravo iz vtičnice in počakajte, da se ohladi.
2. Zunanost naprave obrišite z mehko krpo.

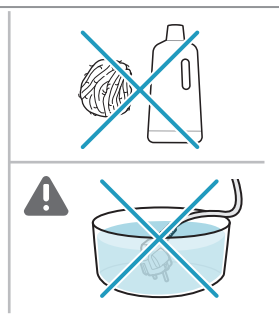
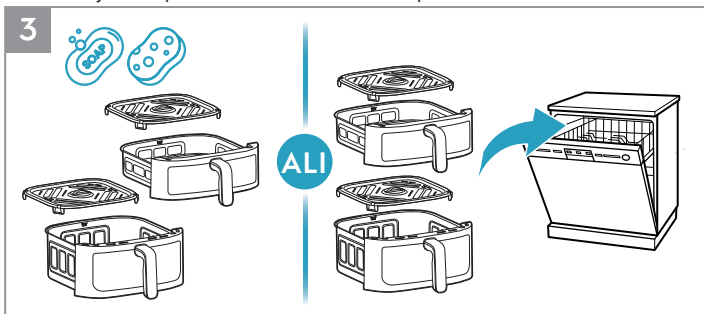

3. Ponev in rešetko očistite s toplo vodo in detergentom za pomivanje posode ali ju postavite v pomivalni stroj.

⚠OPOMBA: Da bi zaščitili premaz proti sprijemanju, se izogibajte uporabi abrazivnih izdelkov za čiščenje ali kovinskih pripomočkov.

OPOZORILO: izdelka, njegovega kabla ali vtiča nikoli ne potaplajte v vodo ali katero koli drugo tekočino.

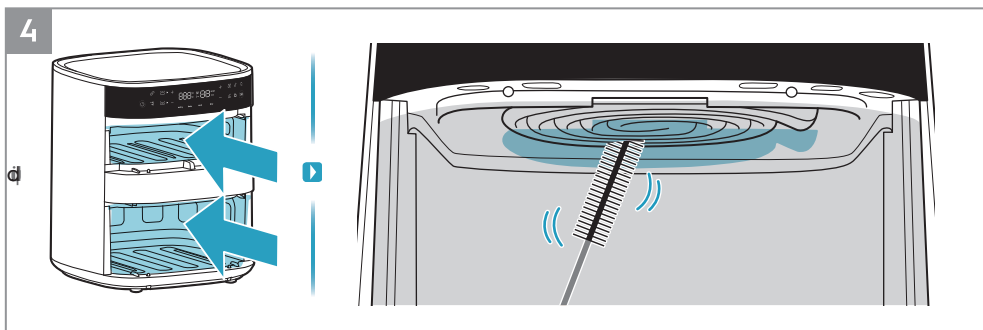











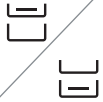







































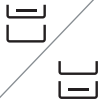











4. Grelni element očistite s krtačo za čiščenje.

OPOMBA: pred čiščenjem grelnega elementa se prepričajte, da je naprava popolnoma ohlajena.

EN
BG
CZ
DE
DK
EE
FI
FR
GR
HR
HU
IT
LT
LV
NO
NL
PL
PT
RO
RU
SE
SI
SK
SR
TR
UA
ES
GE
AL

Vodnik za kuhanje

							
AirFry	7mm/10mm 	 4L	400g	180°C	18min		
		 7L	400g	180°C	18min		
AirFry		 4L	400g	170°C	8min		
		 7L	400g	170°C	10min		
AirFry		 4L	400g/2kosa	140°C	15min		
		 7L	400g/2kosa	140°C	15min		
AirFry		 4L	1000g/8kosa	180°C	28min		
		 7L	1000g/8kosa	180°C	28min		
AirFry		 4L	400g/2kosa	200°C	10min		
		 7L	400g/2kosa	200°C	10min		
AirFry	 	 4L	220g/6palcev	160°C	12min		
		 7L	220g/6palcev	160°C	14min		

							
AirFry		 7L	1200g	180°C	55min		
AirFry		 7L	400g/9kosa	160°C	20min		
Grill		 4L	180g/4kosa	180°C	8min		
		 7L	180g/4kosa	180°C	9min		
Dry		 4L	180g	80°C	3h		
		 7L	180g	80°C	3h		
Dry		 4L	200g	80°C	3h		
		 7L	200g	80°C	3h		

- EN
- BG
- CZ
- DE
- DK
- EE
- FI
- FR
- GR
- HR
- HU
- IT
- LT
- LV
- NO
- NL
- PL
- PT
- RO
- RU
- SE
- SI**
- SK
- SR
- TR
- UA
- ES
- GE
- AL

Kaj storiti, če...

Težava	Preverite, ali...
Ne morete aktivirati ali upravljati naprave.	<ul style="list-style-type: none"> • Naprava je pravilno priklopljena na električno napajanje. • Košari sta pravilno nameščeni. Prepričajte se, da so v celoti potisnjene v napravo, da omogočite električno napajanje. • Čas kuhanja je nastavljen.
Ne morete potisniti košare v napravo.	<ul style="list-style-type: none"> • Košara je napolnjena nad največjo kapaciteto. • Košara je pravilno nameščena. Ko jo namestite v napravo, se mora zaslišati klik. • Predmet je pod košaro, ki ovira njeno pravilno zapiranje.
Iz naprave se kadi bel dim.	<ul style="list-style-type: none"> • Pripravljena hrana je preveč mastna. • Košara, rešetka in grelni element so čisti.
Na zaslonu se prikaze E1	• Odprt tokokrog zgornje košare.
Na zaslonu se prikaze E2	• Kratek sik v zgornji košari.
Na zaslonu se prikaze E3	• Odprt tokokrog spodnje košare.
Na zaslonu se prikaze E4	• Kratek stik v spodnji košari.
Na zaslonu se prikaze E5	• Napaka v komunikaciji krmilne plošče tiskanega vezja.
Na zaslonu se prikaze E6	• Napaka v komunikaciji napajalne tiskanega vezja.

* V primeru, da se na zaslonu prikažejo kode napak, mora napravo popraviti servisni center.

Tehnični podatki

Izdelek	Cvrtnik na vroč zrak
Model	EAFD11B
Napetost (V~)	220 V-240 V
Moč (W)	2700 W
Frekvenca (Hz)	50 ~ 60 Hz
Kapaciteta	4 l+ 7 l



Návod na obsluhu

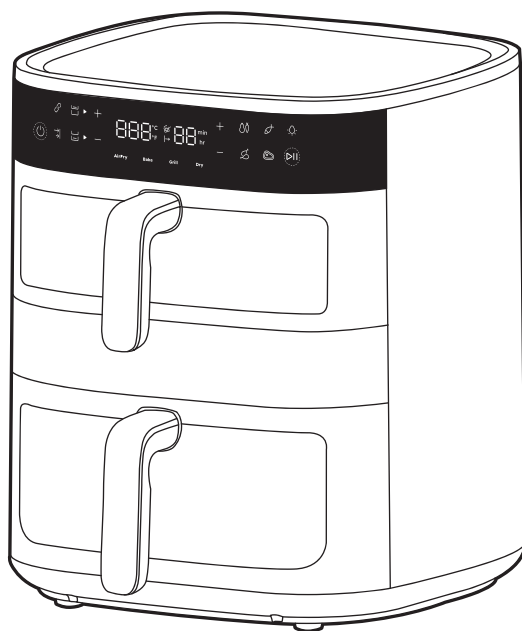

Teplovzdušná fritéza 800 Dual

Všeobecný prehľad

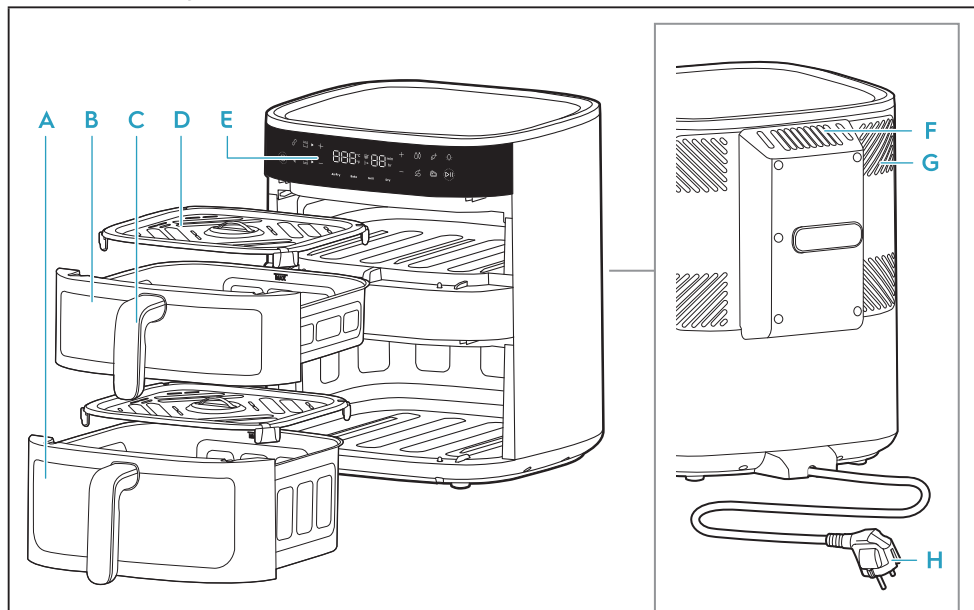

- | | | | |
|---------------------------|---------------------|-------------------------|---------------------------|
| A Spodný kôš (7 l) | C Rúčka koša | E Ovládací panel | G Chladiaci systém |
| B Horný kôš (4 l) | D Mriežka | F Výstup vzduchu | H Napájací kábel |

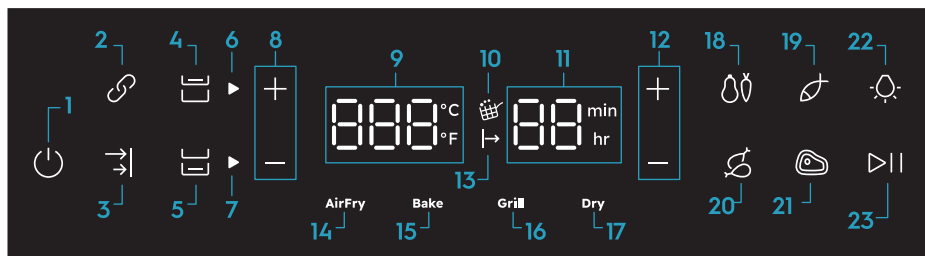

- | | | | |
|-------------------------------------|--|-------------------------------------|----------------------|
| 1. Zapnutie/vypnutie | 8. Ovládanie teploty | 12. Ovládanie času | 19. Ryby |
| 2. Funkcia prepojenia | 9. Indikátor teploty (40 až 200 °C) | 13. Čakanie na varenie | 20. Kuracie mäso |
| 3. Funkcia ukončenia synchronizácie | 10. Pripomenka na pretrepanie | 14. Funkcia Teplovzdušné fritovanie | 21. Steak |
| 4. Ovládanie horného koša | 11. Indikátor času (tepliovzdušné fritovanie: 1 až 99 min, dehydratácia: 1 až 5 h) | 15. Funkcia pečenia | 22. Ovládanie svetla |
| 5. Ovládanie spodného koša | | 16. Funkcia grilu | 23. Fungovanie/pauza |
| 6. Indikátor horného koša | | 17. Funkcia sušenia | |
| 7. Indikátor spodného koša | | 18. Zelenina | |

Pred prvým použitím

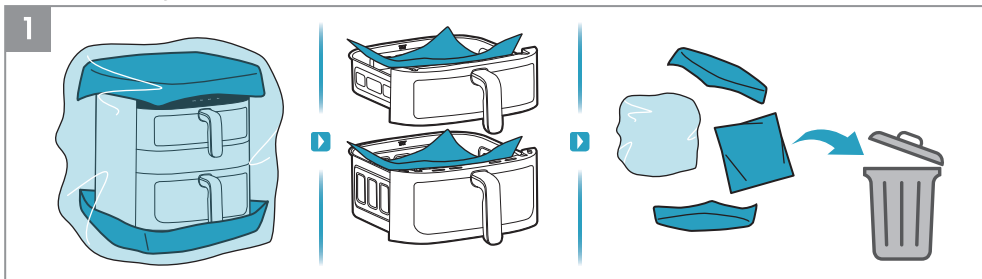

1. Odstráňte všetky obaly a ochranný materiál.

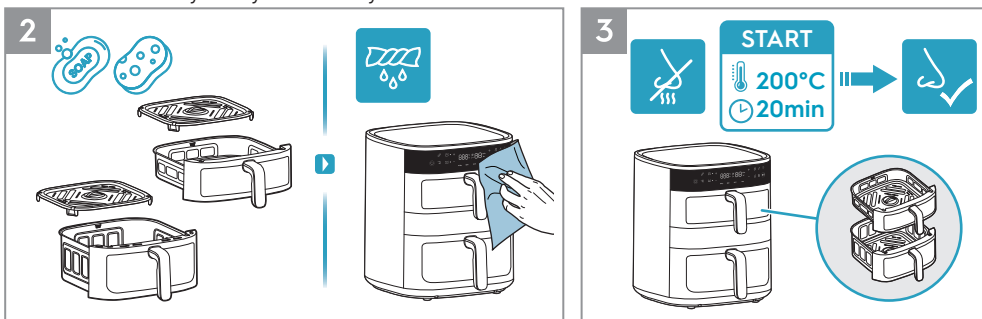

2. Panvicu a mriežku vyčistíte teplou vodou a saponátom na riad. Vnútro a vonkajšok spotrebiča utrite mäkkou handričkou.

3. Je normálne, že nový spotrebič počas niekoľkých prvých použití vydáva zápach. Pred prvým použitím spustíte prázdnu fritézu na 20 minút pri teplote 200 °C, aby ste tomu predišli.

! Bezpečnostné opatrenia

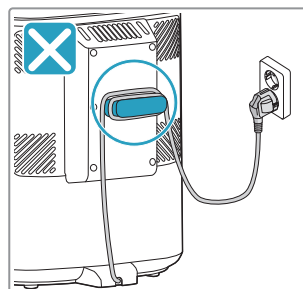
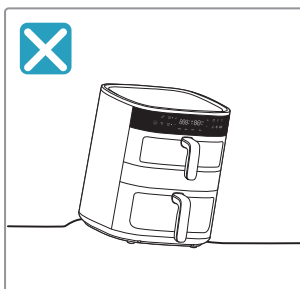
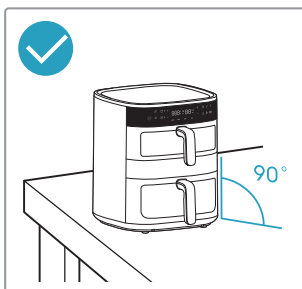
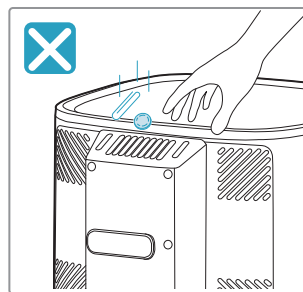
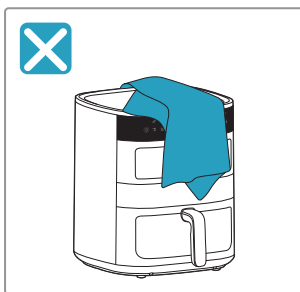
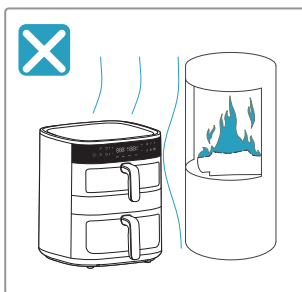





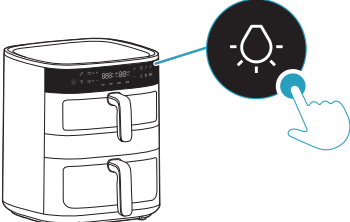
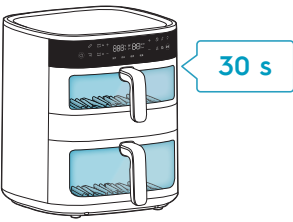
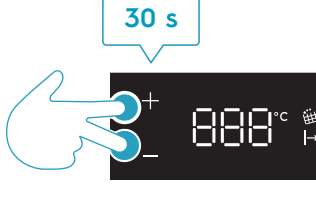
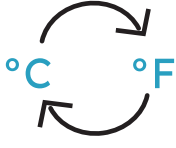









EN
BG
CZ
DE
DK
EE
FI
FR
GR
HR
HU
IT
LT
LV
NO
NL
PL
PT
RO
RU
SE
SI
SK
SR
TR
UA
ES
GE
AL







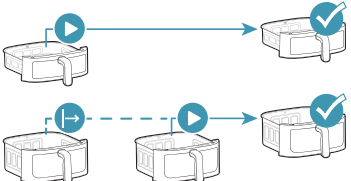







Ovládanie osvetlenia a konverzia teplotnej stupnice

 <p>Ovládanie osvetlenia</p>		
<p>°C/°F</p> <p>Konverzia teplotnej stupnice</p>		

Výber koša

	 <p>4l</p>	 <p>7l</p>	
 <p>Horný kôš</p>			
 <p>Spodný kôš</p>			
 <p>Funkcia prepojenia</p>			
 <p>Funkcia ukončenia synchronizácie</p>			

Prednastavené funkcie

 AirFry					
AirFry	180°C	15min	60-200°C	1-99min	
	170°C	10min	60-200°C	1-99min	
	140°C	15min	60-200°C	1-99min	
	180°C	30min	60-200°C	1-99min	
	200°C	10min	60-200°C	1-99min	
Bake	170°C	15min	60-200°C	1-99min	
Grill	200°C	5min	60-200°C	1-99min	
Dry	80°C	5h	40-80°C	1-5h	

Pred varením

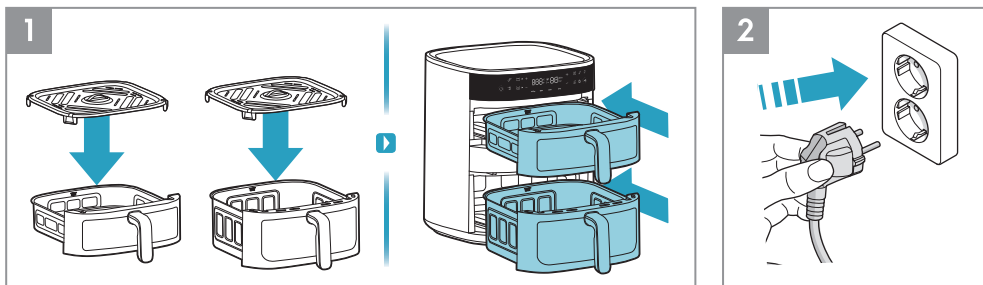

1. Pred každým varením vložte mriežku do koša (žiaruvzdornú silikónovú podložku na nožičkách mriežky nie je potrebné vyberať) a úplne zatlačte koš do spotrebiča.
2. Zasuňte sieťovú zástrčku do elektrickej zásuvky.

Spôsob použitia – jeden kôš

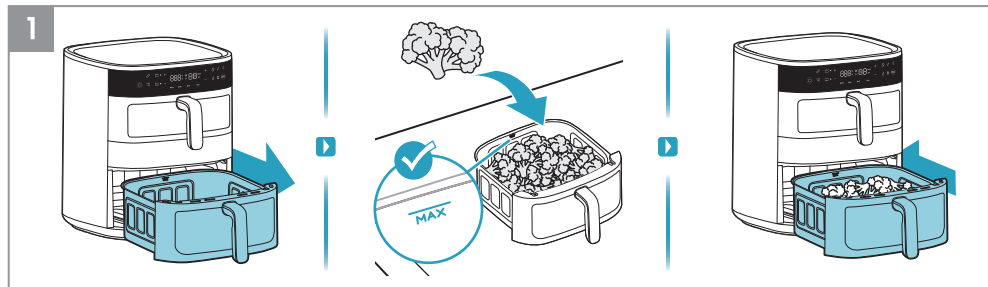

1. Vytiahnite jeden kôš a položte ho na stabilný povrch, vložte potraviny do koša a sledujte údaj o kapacite "MAX.". Potom zasuňte kôš s potravinami úplne späť do spotrebiča.

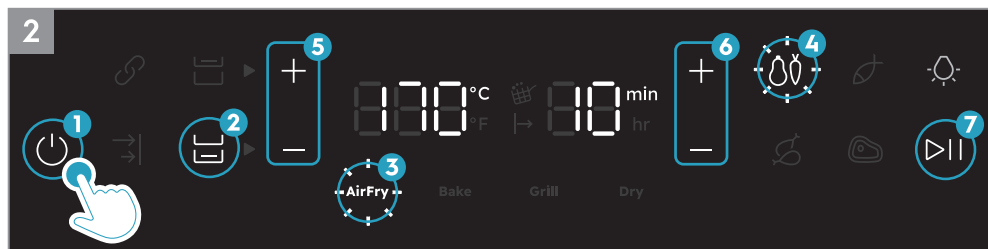

2. Stlačte tlačidlo zapnutie/vypnutie. Najprv vyberte kôš s potravinami. Potom vyberte požadovaný spôsob varenia, napríklad funkciu Teplovzdušné fritovanie. Nastavte čas a teplotu podľa vlastnej chuti alebo vyberte jeden z prednastavených receptov, napríklad Zelenina. Nakoniec stlačte tlačidlo Fungovanie/pauza.

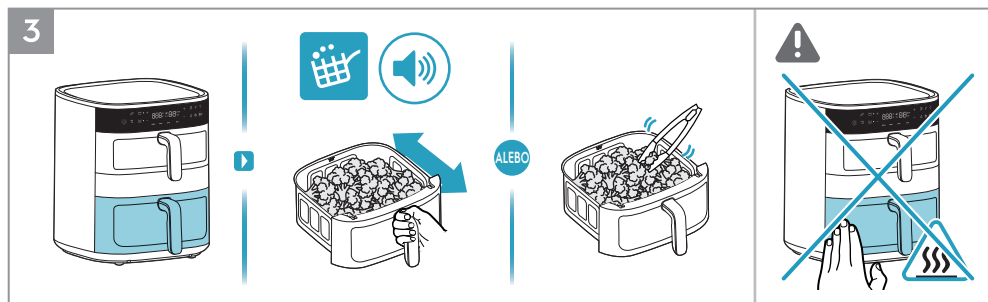

3. Keď sa počas procesu varenia rozsvieti ikona "Pripomenka na pretrepanie" a ozve sa pípnutie, použite žiaruvzdorné nástroje na jednorazové otočenie jedla alebo opatrne mierne pretrepte jedlom vo fritovačom koši.

⚠ **POZOR:** Fritovačím košom silno netraсте, aby nedošlo k rozstrekovaniu jedla a popáleniu.

⚠ **POZOR:** Počas používania spotrebiča buďte opatrní na horúce povrchy.

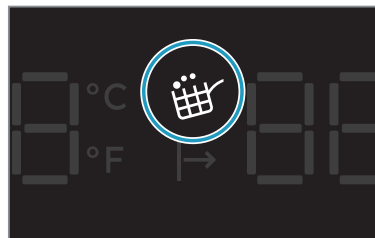

Pripomenka na pretrepanie

Funkcia "Pripomenka na pretrepanie" sa aktivuje počas funkcie Teplovzdušné fritovanie a prednastavených receptov, ako sú zelenina, ryby, kuracie stehná a steaky.

Keď nastane čas na pretrepanie alebo otočenie potravín, ikona "Pripomenka na pretrepanie" sa rozsvieti a bude blikať jednu minútu, pričom sa trikrát zopakuje signál pípnutia.

Funkcia "Pripomenka na pretrepanie" nie je povinná, preto bude varenie pokračovať ako zvyčajne, aj keď jedlo neobrátime alebo nepretrepete.



4. Na konci varenia spotrebič vydá signál pípnutia. Opatrne vyberte koš a položte ho na teplovzdorný povrch. Po použití spotrebiča ho odpojte z elektrickej zásuvky.

⚠ **POZOR:** Pri otvorení koša v polovici alebo na konci varenia môže z neho vychádzať horúca para. Pri otváraní sa uistite, že vaša tvár, ruky a paže sú mimo dosahu pary.

Spôsob použitia – horný + spodný koš

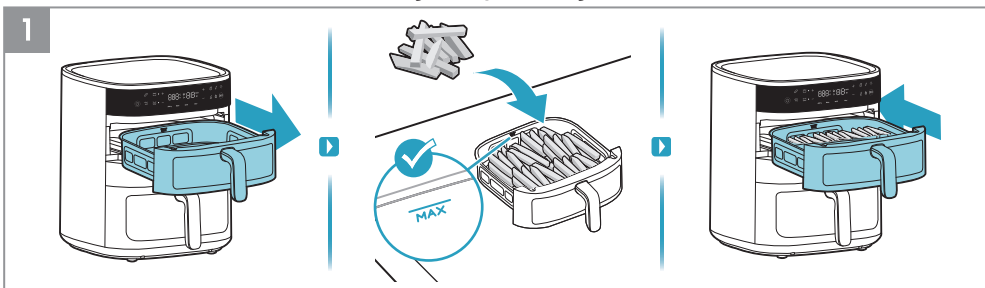

1. Najprv vytiahnite horný koš a vložte doň potraviny, napríklad zemiakové hranolčeky.

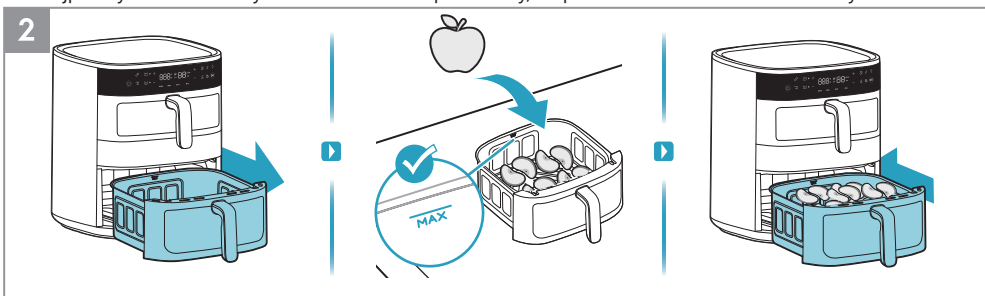

2. Potom vytiahnite spodný koš a vložte doň potraviny, napríklad plátky jablák.



3. Stlačte tlačidlo zapnutie/vypnutie. Najprv vyberte horný koš. Potom vyberte požadovaný spôsob varenia, napríklad funkciu Teplovzdušné fritovanie. Nastavte čas a teplotu podľa vlastnej chuti alebo vyberte jeden z prednastavených receptov, napríklad Zelenina. Nakoniec stlačte tlačidlo Fungovanie/pauza.



4. Potom vyberte spodný kód. Potom vyberte požadovaný spôsob varenia, napríklad funkciu Sušenie. Čas a teplotu upravte podľa vlastnej chuti. Nakoniec stlačte tlačidlo Fungovanie/pauza.

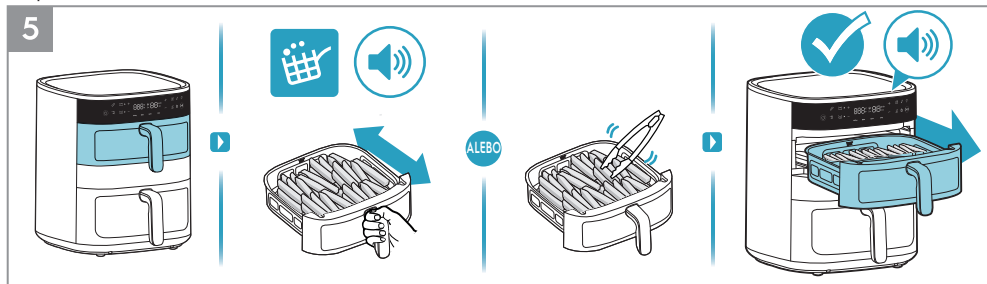

5. Keď sa počas procesu varenia rozsvieti ikona "Pripomenka na pretrepanie" a ozve sa pipnutie, použite žiaruvzdorné nástroje na jednorazové otočenie jedla alebo opatrne mierne pretřpte jedlom vo fritovacom koši. Po skončení varenia v hornom koši spotrebič vydá signál pipnutia.

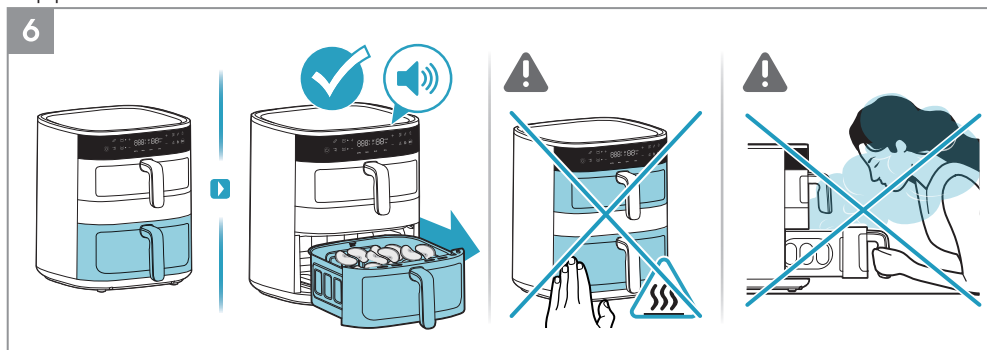

6. Na konci času varenia v spodnom koši spotrebič vydá signál pípnutia.

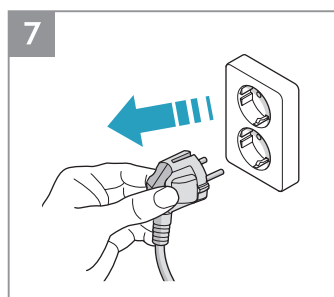

7. Po použití spotrebiča ho odpojte z elektrickej zásuvky.

Spôsob použitia – funkcia prepojenia

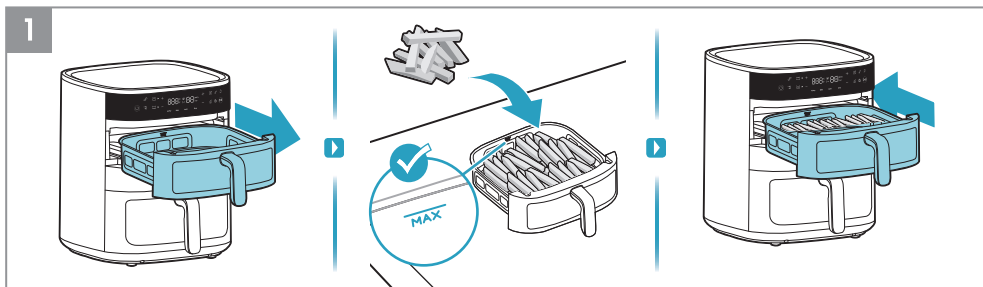

1. Najprv vyťahnite horný kôš a vložte doň potraviny, napríklad zemiakové hranolčky.

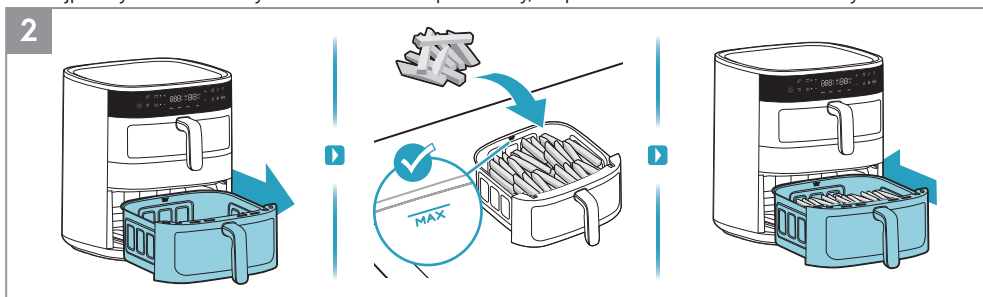

2. Potom vyťahnite spodný kôš a vložte doň potraviny, napríklad zemiakové hranolčky.



3. Stlačte tlačidlo zapnutie/vypnutie. Najprv vyberte funkciu prepojenia. Potom vyberte požadovaný spôsob varenia, napríklad funkciu Teplovzdušné fritovanie. Nastavte čas a teplotu podľa vlastnej chuti alebo vyberte jeden z prednastavených receptov. Nakoniec stlačte tlačidlo Fungovanie/pauza.

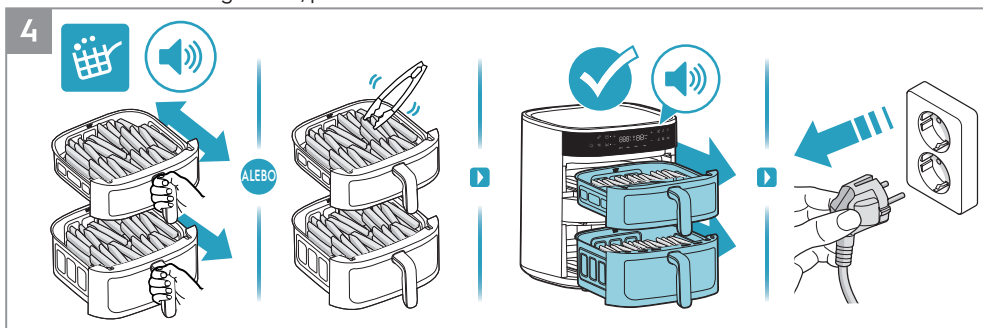

4. Keď sa počas procesu varenia rozsvieti ikona "Pripomenka na pretrepanie" a ozve sa pípnutie, použite žiaruvzdorné nástroje na jednorazové otočenie jedla alebo opatrne mierne pretrepte jedlom vo fritovacom koši. Na konci varenia spotrebič vydá signál pípnutia. Po použití spotrebiča ho odpojte z elektrickej zásuvky.

EN
BG
CZ
DE
DK
EE
FI
FR
GR
HR
HU
IT
LT
LV
NO
NL
PL
PT
RO
RU
SE
SI
SK
SR
TR
UA
ES
GE
AL

Spôsob použitia – funkcia ukončenia synchronizácie

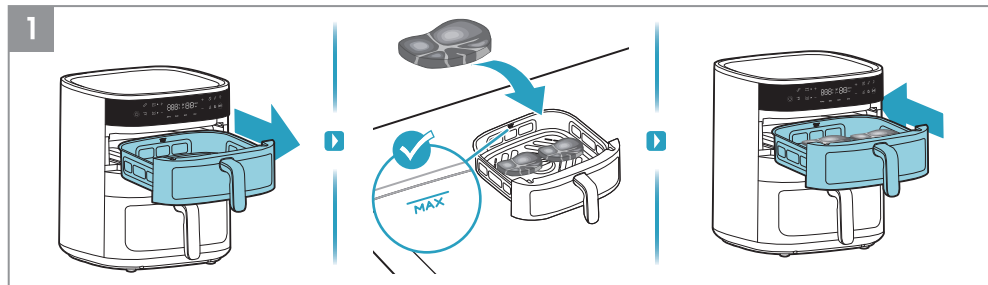

1. Najprv vyťahnite horný kôš a vložte doň potraviny, napríklad steak.

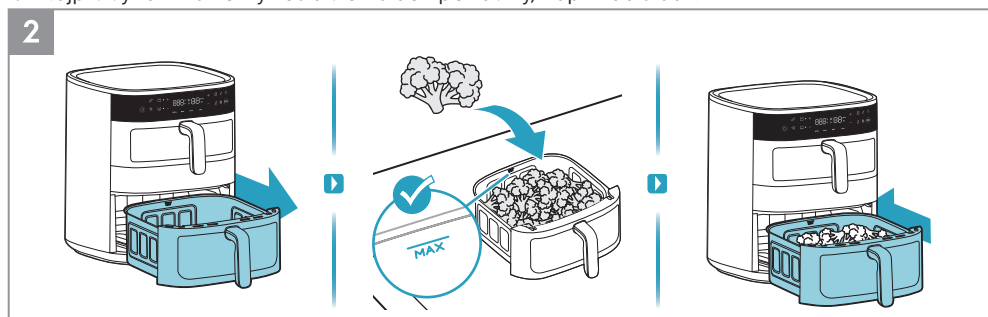

2. Potom vyťahnite spodný kôš a vložte doň potraviny, napríklad brokolicu.



3. Stlačte tlačidlo zapnutie/vypnutie. Vyberte funkciu ukončenia synchronizácie. Najprv vyberte horný kôš a potom požadovaný spôsob varenia, napríklad funkciu Teplovzdušné fritovanie. Upravte čas a teplotu podľa vlastnej chuti alebo vyberte jeden z prednastavených receptov, napríklad steak.



4. Potom vyberte spodný kôš, vyberte požadovaný spôsob varenia, napríklad funkciu Teplovzdušné fritovanie. Nastavte čas a teplotu podľa vlastnej chuti alebo vyberte jeden z prednastavených receptov. Nakoniec stlačte tlačidlo Fungovanie/pauza.

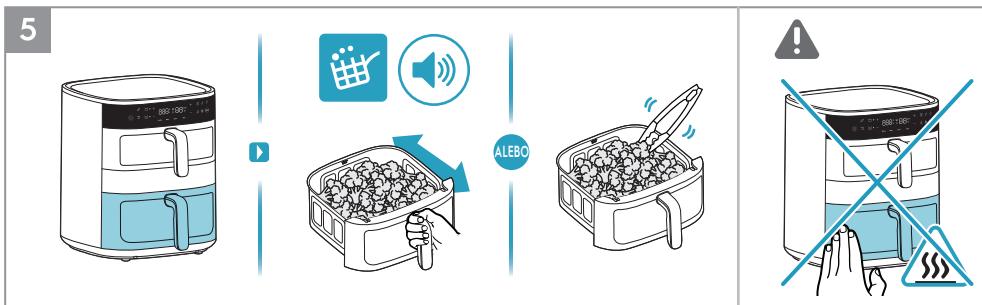

5. Najprv sa na varenie uprednostní spodný kôš s dlhším nastaveným časom. Keď sa počas procesu varenia rozsvieti ikona "Pripomienka na pretrepanie" a ozve sa pípnutie, použite žiaruvzdorné nástroje na jednorazové otočenie jedla alebo opatrne mierne pretrepte jedlom vo fritovačom koši.

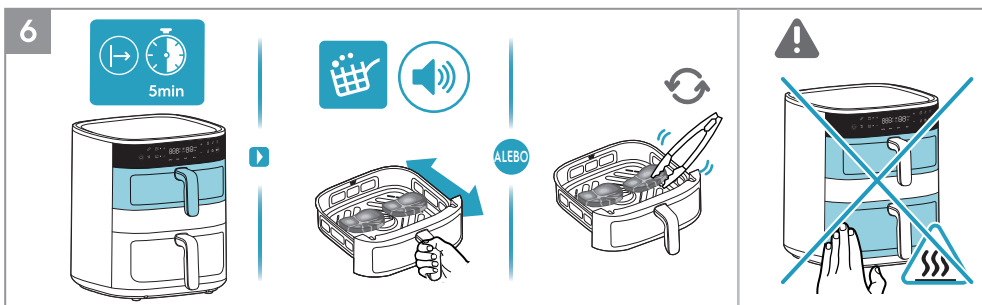

6. Potom začne variť horný kôš s kratším nastaveným časom. Keď sa počas procesu varenia rozsvieti ikona "Pripomienka na pretrepanie" a ozve sa pípnutie, použite žiaruvzdorné nástroje na jednorazové otočenie jedla alebo opatrne mierne pretrepte jedlom vo fritovačom koši.

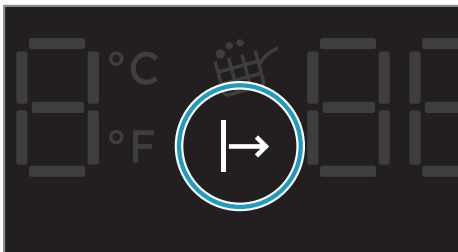

Indikátor čakania na varenie

Keď je aktivovaná "funkcia ukončenia synchronizácie", kôš s kratším časom varenia počká na varenie, kým kôš s dlhším časom varenia chvíľu varí, aby oba koše mohli ukončiť varenie v rovnakom čase. Počas tohto obdobia bude svietiť "indikátor čakania na varenie", kým sa varenie nezačne.

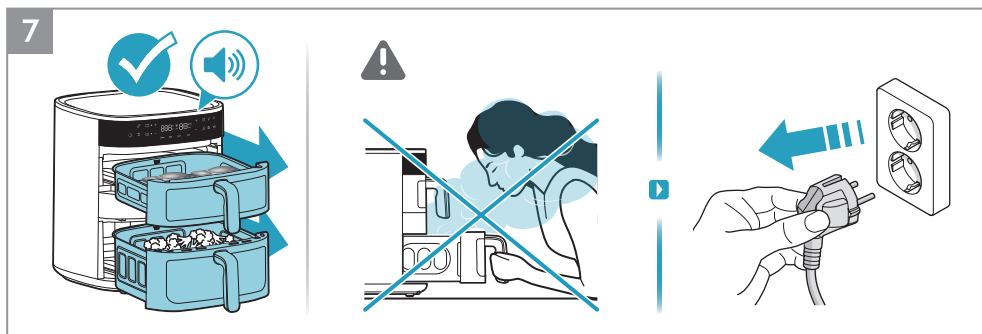

7. Na konci varenia spotrebič vydá signál pípnutia. Po použití spotrebiča ho odpojte z elektrickej zásuvky.

Čistenie

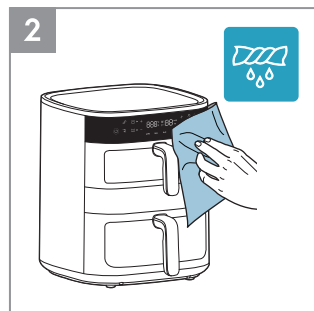
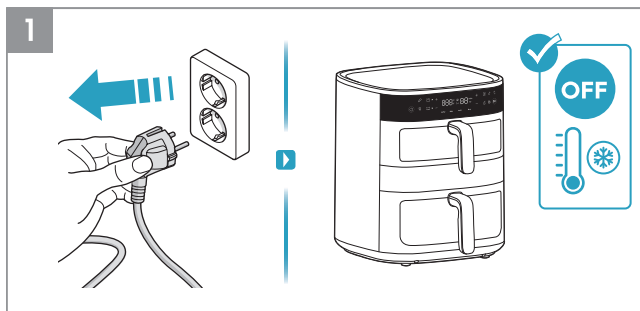

1. Pred čistením spotrebiča ho vždy odpojte od elektrickej siete a počkajte, kým vychladne.
2. Vonkajšiu časť spotrebiča utrite mäkkou handričkou.

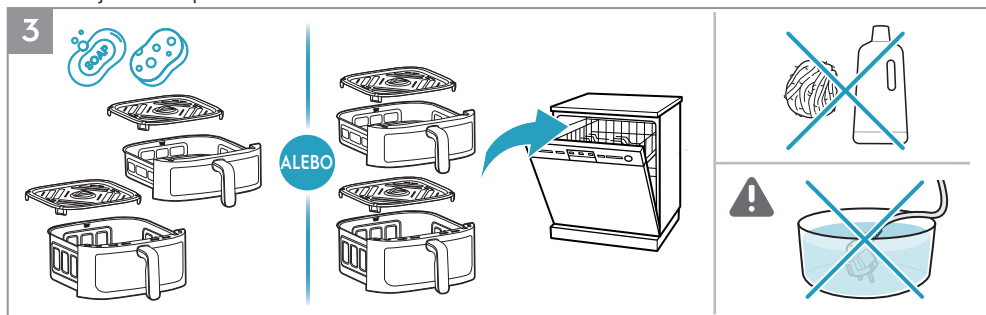

3. Panvicu a mriežku vyčistíte teplou vodou a saponátom na riad alebo ich vložte do umývačky riadu.

▲POZNÁMKA: Nepoužívajte abrazívne čistiace prostriedky ani kovové nástroje, aby ste chránili nepriľnavý povrch.



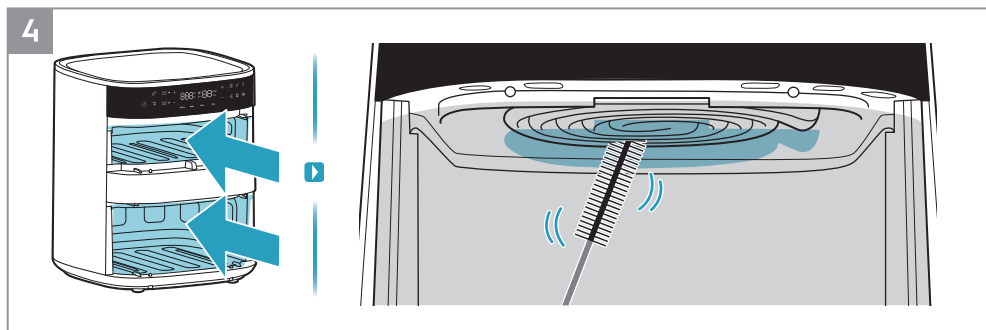









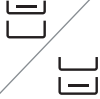















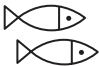









POZOR: Nikdy neponárajte výrobok, jeho kábel ani zástrčku do vody alebo inej kvapaliny.



4. Ohrevné teleso vyčistíte čistiacou kefkou.













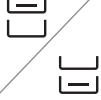





















POZNÁMKA: Pred čistením ohrevného telesa sa uistite, že spotrebič úplne vychladol.

Sprievodca varením

							
AirFry	7mm/10mm 	 4l	400g	180°C	18min		
		 7l	400g	180°C	18min		
AirFry		 4l	400g	170°C	8min		
		 7l	400g	170°C	10min		
AirFry		 4l	400g/2ks	140°C	15min		
		 7l	400g/2ks	140°C	15min		
AirFry		 4l	1000g/8ks	180°C	28min		
		 7l	1000g/8ks	180°C	28min		
AirFry		 4l	400g/2ks	200°C	10min		
		 7l	400g/2ks	200°C	10min		
AirFry		 4l	220g/6palcov	160°C	12min		
		 7l	220g/6palcov	160°C	14min		

- EN
- BG
- CZ
- DE
- DK
- EE
- FI
- FR
- GR
- HR
- HU
- IT
- LT
- LV
- NO
- NL
- PL
- PT
- RO
- RU
- SE
- SI
- SK**
- SR
- TR
- UA
- ES
- GE
- AL

EN
BG
CZ
DE
DK
EE
FI
FR
GR
HR
HU
IT
LT
LV
NO
NL
PL
PT
RO
RU
SE
SI
SK
SR
TR
UA
ES
GE
AL

							
		 7l	1200g	180°C	55min		
		 7l	400g/9ks	160°C	20min		
		 4l	180g/4ks	180°C	8min		
		 7l	180g/4ks	180°C	9min		
		 4l	180g	80°C	3h		
		 7l	180g	80°C	3h		
		 4l	200g	80°C	3h		
		 7l	200g	80°C	3h		

Čo robiť, ak...

Problém	Skontrolujte, či...
Spotrebič nemôžete aktivovať ani prevádzkovať.	<ul style="list-style-type: none"> Spotrebič je správne pripojený k elektrickej sieti. Koš sú v správnej polohe. Uistite sa, že sú úplne zasunuté do spotrebiča, aby sa umožnilo elektrické napájanie. Čas varenia je nastavený.
Kôš nemôžete zasunúť do spotrebiča.	<ul style="list-style-type: none"> Kôš je naplnený nad svoju maximálnu kapacitu. Kôš je umiestnený správne. Pri vkladaní do jednotky musí kliknúť. Pod košom sa nachádza predmet, ktorý bráni jeho správne zatvoreniu.
Zo spotrebiča vychádza biely dym.	<ul style="list-style-type: none"> Jedlo, ktoré pripravujete, je príliš masťné. Kôš, mriežka a ohrevné teleso sú čisté.
Na displeji sa zobrazí E1	<ul style="list-style-type: none"> Otvorený obvod horného koša.
Na displeji sa zobrazí E2	<ul style="list-style-type: none"> Skrat horného koša.
Na displeji sa zobrazí E3	<ul style="list-style-type: none"> Otvorený obvod spodného koša.
Na displeji sa zobrazí E4	<ul style="list-style-type: none"> Skrat spodného koša.
Na displeji sa zobrazí E5	<ul style="list-style-type: none"> Zlyhanie komunikácie s riadiacou doskou plošných spojov (PCBA).
Na displeji sa zobrazí E6	<ul style="list-style-type: none"> Zlyhanie komunikácie s výkonovou doskou plošných spojov (PCBA).

* V prípade, že sa na displeji zobrazia kódy chýb, spotrebič musí byť opravený v servisnom stredisku.

Technické údaje

Produkt	Tepl vzdušná fritéza
Model	EAFD11B
Napätie (V-)	220 V - 240 V
Výkon (W)	2700 W
Frekvencia (Hz)	50 - 60 Hz
Kapacita	4 l + 7 l



Упутство за употребу

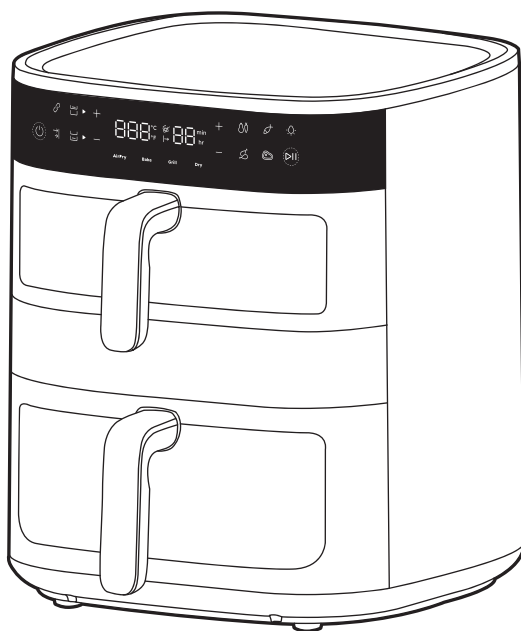

Фритеза на вру ћ ваздух дуал 800

Општи преглед

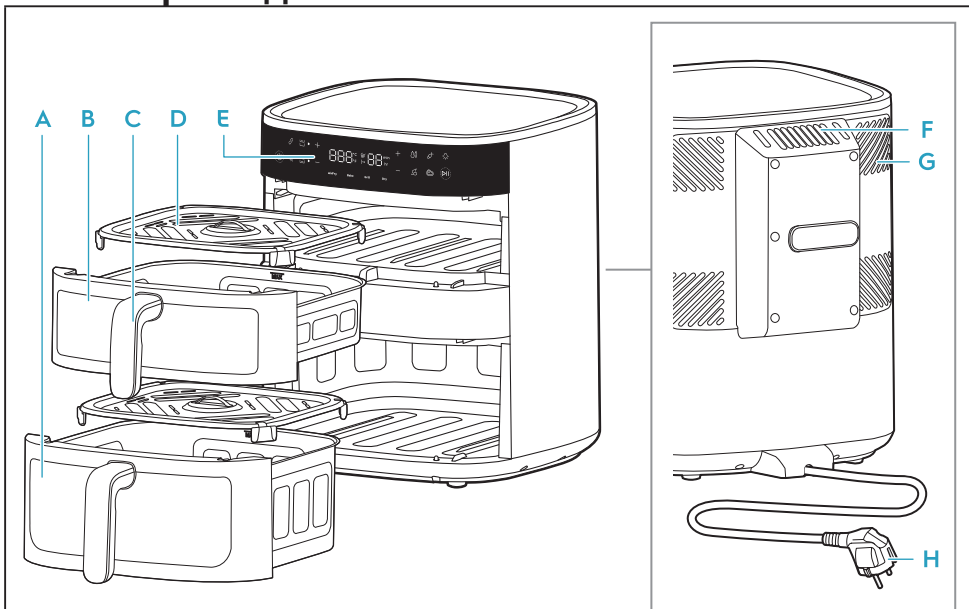

- A** До њ а корпа (7 л) **C** Ручка корпе **E** Контролна табла **G** Расхладни систем
B Гор њ а корпа (4 л) **D** Решетка **F** Излаз ваздуха **H** Главни кабл

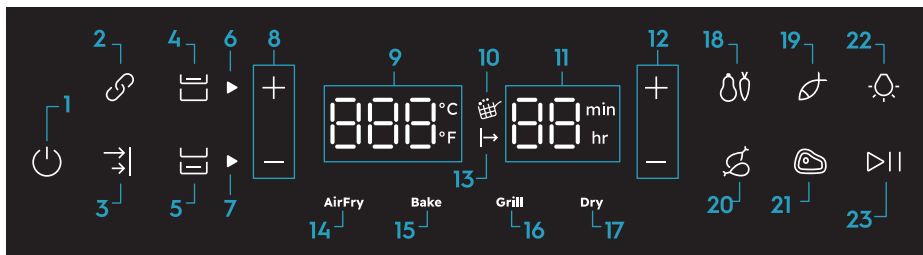

1. Укључено / искључено
2. Функција повезивања
3. Функција завршетка синхронизације
4. Контрола горње корпе
5. Контрола доње корпе
6. Индикатор горње корпе
7. Индикатор доње корпе
8. Контрола температуре
9. Индикатор температуре (40-200°C)
10. Подсетник за протресање
11. Индикатор времена (Пржење врућим ваздухом: 1-99 мин, Дехидратација: 1-5 сати)
12. Контрола времена
13. Чекање на припрему
14. Функција пржења ваздухом
15. Функција печења
16. Функција роштиља
17. Функција сушења
18. Поврће
19. Риба
20. Пилетина
21. Одрезак
22. Контрола светла
23. Рад / Пауза

Пре прве употребе

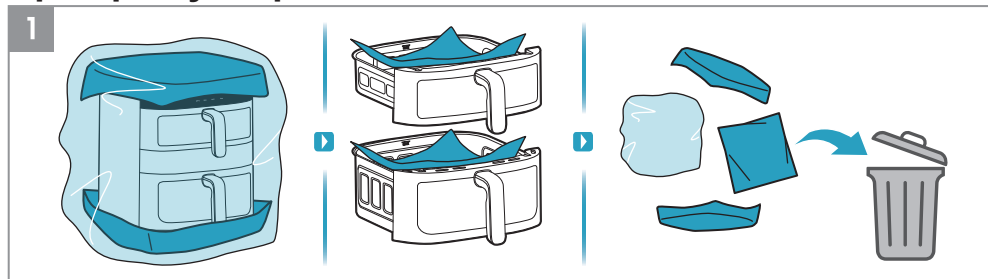

1. Уклоните сву амбалажу и заштитни материјал .

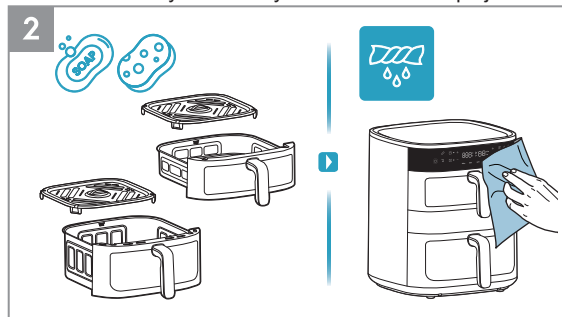

2. Очистите тигањ и решетку топлом водом и детерџентом за судове . Обришите унутрашњост и спољашњост уређаја меком крпом .

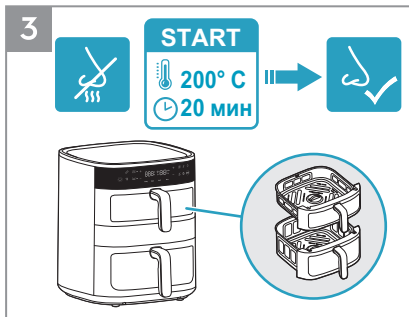

3. Нормално је да нови уређај емитује мирисе првих неколико пута када се користи . Да бисте то избегли , укључите празну фритезу на 200° C 20 минута пре прве употребе .



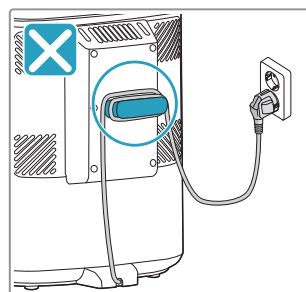
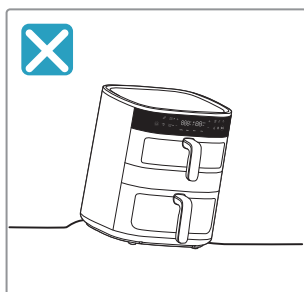
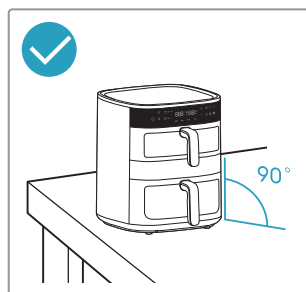
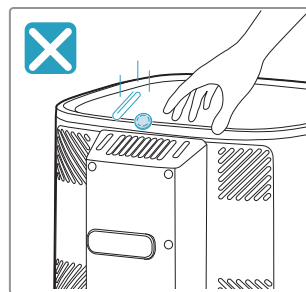
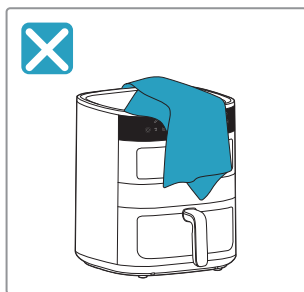
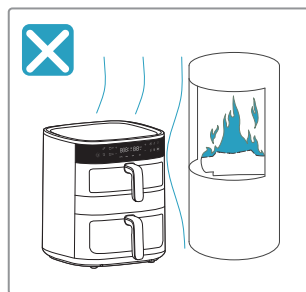



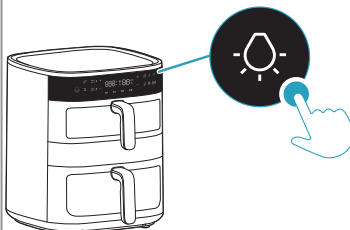
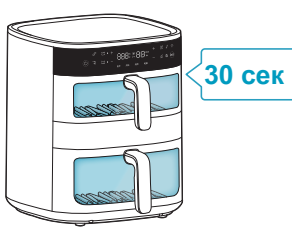
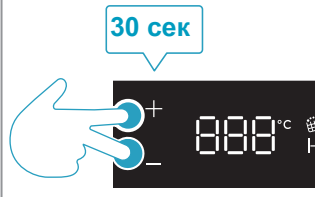
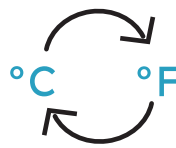







! Мере предострожности



Контрола осветљења и конверзија температурне скале





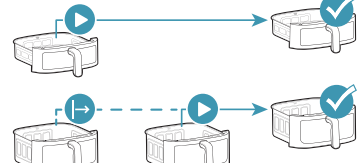





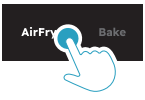



 <p>Контрола светла</p>		 <p>30 сек</p>
<p>°C/°F</p> <p>Конверзија температурне скале</p>	 <p>30 сек</p>	

Одабир корпе

	 <p>4 л</p>	 <p>7 л</p>	
 <p>Горња корпа</p>			
 <p>Доња корпа</p>			
 <p>Функција повезивања</p>			
 <p>Функција завршетка синхронизације</p>			

EN
BG
CZ
DE
DK
EE
FI
FR
GR
HR
HU
IT
LT
LV
NO
NL
PL
PT
RO
RU
SE
SI
SK
SR
TR
UA
ES
GE
AL

Унапред подешене функције

					
AirFry	180° C	15 мин	60~200° C	1~99 мин	
	170° C	10 мин	60~200° C	1~99 мин	
	140° C	15 мин	60~200° C	1~99 мин	
	180° C	30 мин	60~200° C	1~99 мин	
	200° C	10 мин	60~200° C	1~99 мин	
Bake	170° C	15 мин	60~200° C	1~99 мин	
Grill	200° C	5 мин	60~200° C	1~99 мин	
Dry	80° C	5 сати	40~80° C	1~5 сати	

Пре припреме

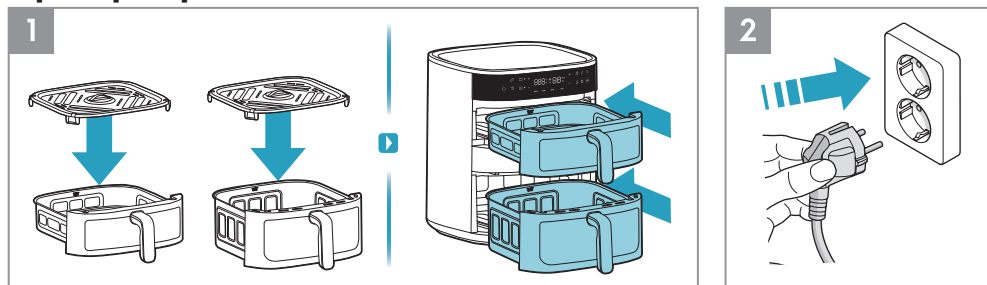

1. Пре сваке припреме, ставите решетку у корпу (силиконску подлогу решетке отпорну на топлоту не треба уклањати) и потпуно увуците корпу у уређај.
2. Уметните утикач у утичницу .

Како се користи - Ј една корпа

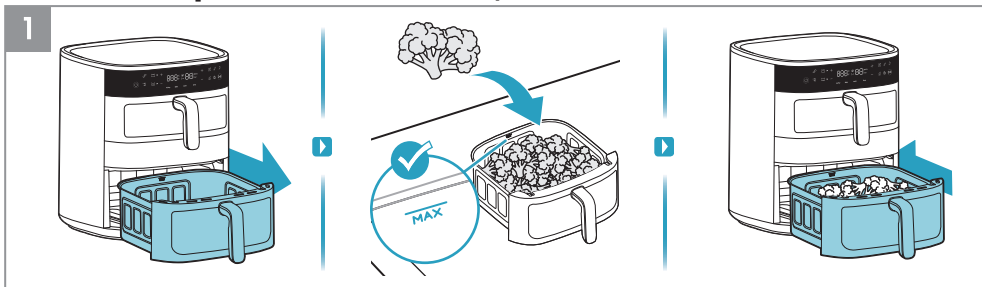

1. Извучите једну корпу и поставите је на стабилну површину, ставите храну у корпу, воде ћ и рачуна о ознаци капацитета "MAX". Затим до краја увучите корпу са храном у уређај.

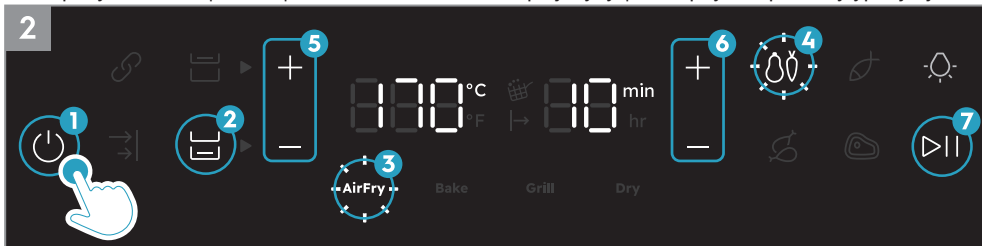

2. Притисните дугме за укључивање / искључивање. Прво изаберите корпу са храном. Затим изаберите жељени начин припреме, на пример, функцију пржења врућим ваздухом. Подесите време и температуру по свом укусу или изаберите један од унапред подешених рецепата, на пример, поврће. На крају, притисните дугме за Рад / Пауза.

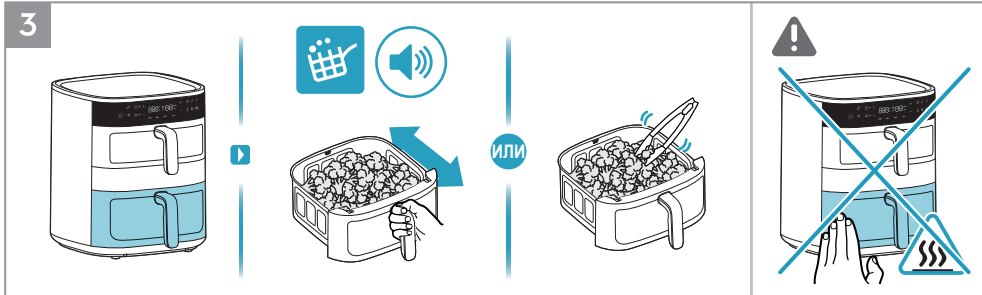

3. Када се икона "Подсетник за протресање" укључи и огласи звучни сигнал током процеса припреме, користите алате отпорне на топлоту да једном окренете храну или пажљиво благо протресете храну у корпи за пржење.

- ⚠ **ОПРЕЗ:** Немојте снажно трести корпу за пржење како бисте избегли прскање хране и опекотине.
- ⚠ **ОПРЕЗ:** Будите опрезни са врућим површинама када је уређај у употреби.

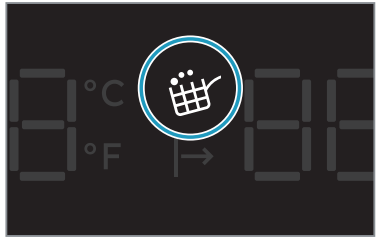

Подсетник за протресање
 "Подсетник за протресање" се активира током функције пржења врућим ваздухом и унапред подешених рецепата, као што су поврће, риба, пилећ и батаци и одрезак. Када је време да протресете или окренете храну, икона "Подсетник за протресање" ће се укључити и трептати један минут, док ће се звучни сигнал поновити три пута.
 "Подсетник за протресање" није обавезан, па ће се припрема наставити уобичајено, чак и ако се хана не окрене или протресе.

- EN
- BG
- CZ
- DE
- DK
- EE
- FI
- FR
- GR
- HR
- HU
- IT
- LT
- LV
- NO
- NL
- PL
- PT
- RO
- RU
- SE
- SI
- SK
- SR**
- TR
- UA
- ES
- GE
- AL



4. По завршетку приpreме, уређај ће се огласити звучним сигналом. Пажљиво извадите корпу и ставите је на површину отпорну на топлоту. Искључите уређај из струје након употребе.

⚠ **ОПРЕЗ:** Врућа испарења могу изаћи и из корпе када се отвори усред или на крају приpreме. Уверите се да су вам лице, руке и шаке даље од паре када је отварате.

Како се користи - Горња + Доња корпа

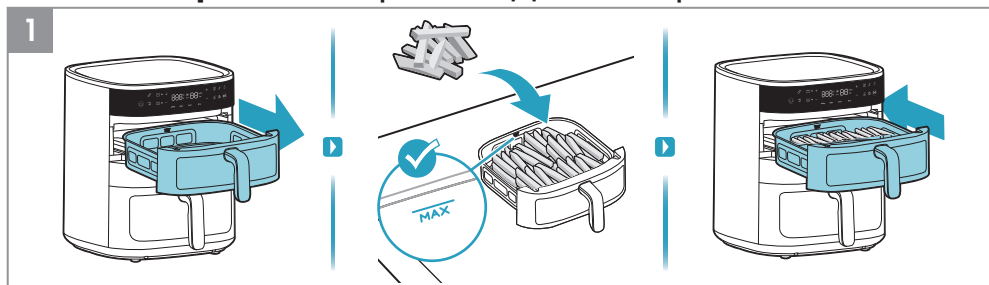

1. Прво, извучите горњу корпу и у њу ставите храну, на пример, помфрит.

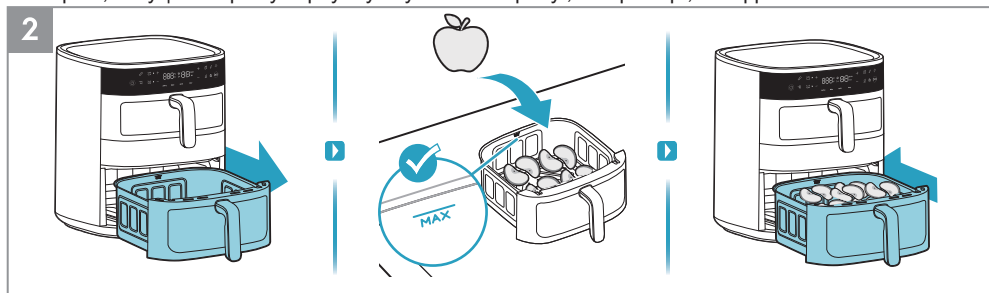

2. Затим, извучите доњу корпу и у њу ставите храну, на пример, кришке јабуке.



3. Притисните дугме за укључивање / искључивање. Прво одаберите горњу корпу. Затим изаберите жељени начин приpreме, на пример, функцију пржења ваздухом. По десетиме време и температуру по свом укусу или изаберите један од унапред подешених рецепа, на пример, поврће. На крају, притисните дугме за Рад / Пауза.



4. Потом, одаберите до њ у корпу . Затим изаберите же љ ени начин припреме , на пример , ф ункци ј у суше њ а . Прилагодите време и температуру свом укусу . На кра ју , притисните дуг ме за Рад / Пауза .

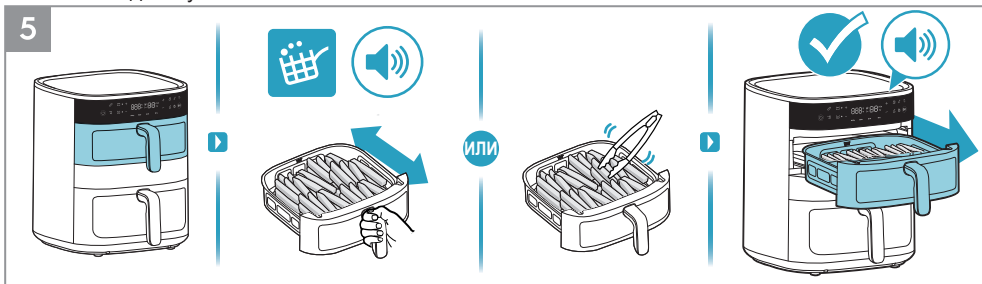

5. Када се икона "Подсетник за протреса њ е" ук љ учи и огласи звучни сигнал током процеса п припреме , користите алате отпорне на топлоту да ј едном окренете храну или паж љ иво бла го протресете храну у корпи за прже њ е . По завршетку припреме у гор њ о ј корпи , уре ђ а ј ћ е се огласити звучним сигналом .

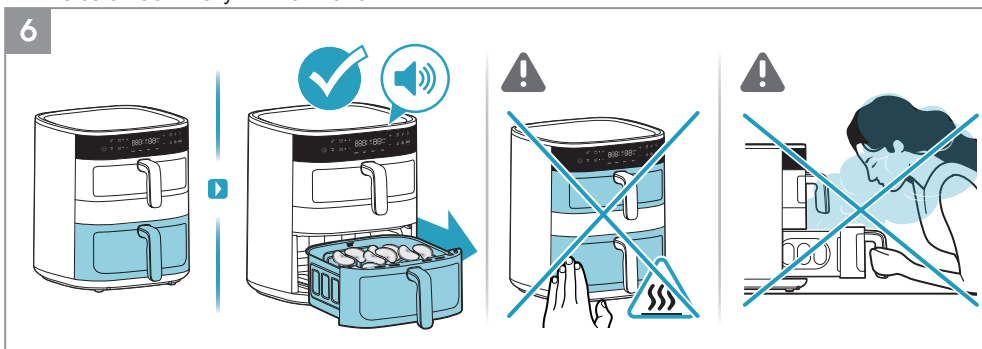

6. По завршетку припреме у до њ о ј корпи , уре ђ а ј ћ е се огласити звучним сигналом .

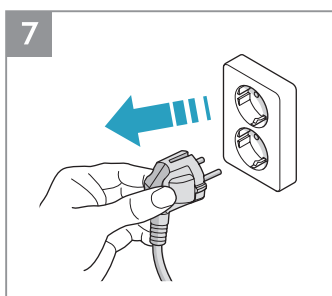

7. Иск љ учите уре ђ а ј из стру је е након употребе .

Како се користи - Функција повезивања

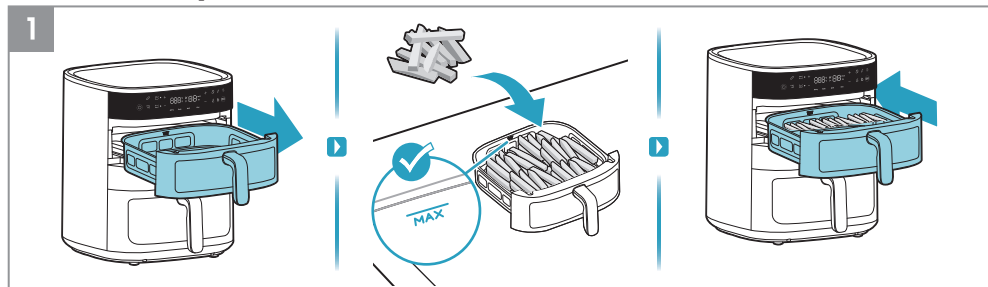

1. Прво, извуците горњи у корпу и у њу ставите храну, на пример, помфрит.

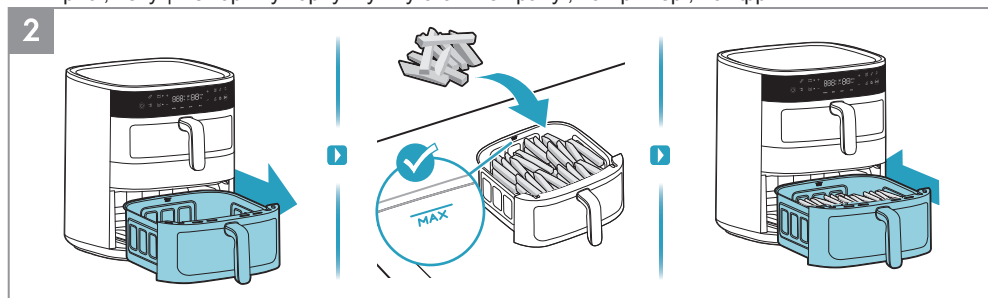

2. Потом извуците доњи у корпу и у њу ставите храну, на пример, помфрит.

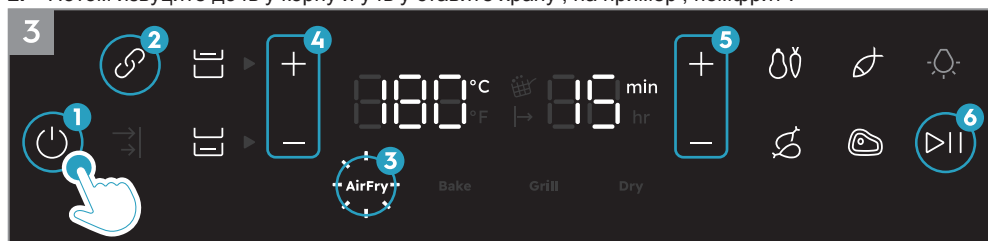

3. Притисните дугме за укључивање/искључивање. Прво изаберите функцију повезивања. Затим изаберите жељени начин припреме, на пример, функцију пржења врућим ваздухом. Подесите време и температуру по свом укусу или изаберите један од унапред подешених рецепата. На крају, притисните дугме за Рад/Пауза.

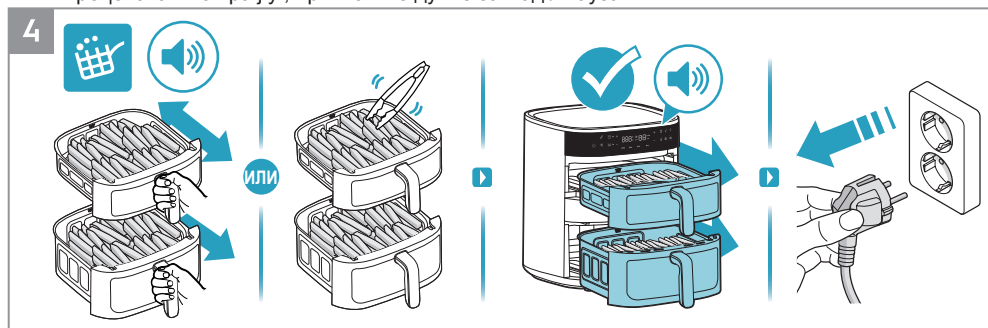

4. Када се икона "Подсетник за протресање" укључи и огласи звучни сигнал током процеса припреме, користите алате отпорне на топлоту да једном окренете храну или пажљиво благо протресете храну у корпи за пржење. По завршетку припреме, уређај ће се огласити звучним сигналом. Искључите уређај из струје након употребе.

Како се користи - Функција завршетка синхронизације

EN
BG
CZ
DE
DK
EE
FI
FR
GR
HR
HU
IT
LT
LV
NO
NL
PL
PT
RO
RU
SE
SI
SK
SR
TR
UA
ES
GE
AL

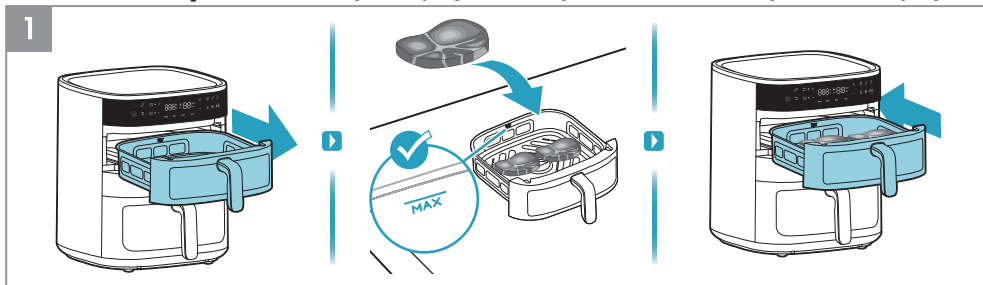

1. Прво, извуците горњи у корпу и у њу ставите храну, на пример, одрезак.

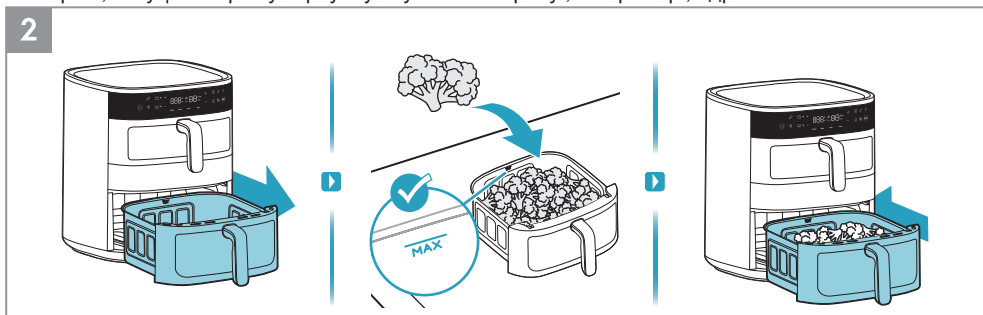

2. Потом извуците доњи у корпу и у њу ставите храну, на пример, броколи.



3. Притисните дугме за укључивање / искључивање. Изаберите Функцију завршетка синхронизације. Прво одаберите горњи у корпу, а затим изаберите жељени начин припреме, на пример, функцију пржења у врућим ваздухом. Подесите време и температуру по свом укусу или изаберите један од унапред подешених рецепата, на пример, одрезак.

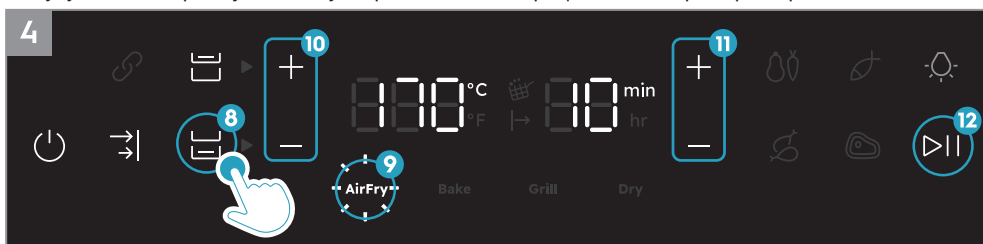

4. Затим изаберите доњи у корпу, изаберите жељени начин припреме, на пример, функцију пржења у врућим ваздухом. Подесите време и температуру по свом укусу или изаберите један од унапред подешених рецепата. На крају, притисните дугме за Рад / Пауза.

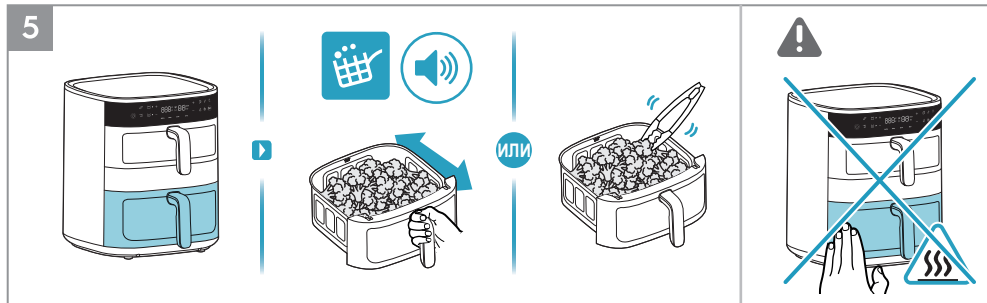

5. Прво, до ња корпа са дуже постављеним временом ће имати приоритет за припрему. Када се икона “Подсетник за протресање” укључи и огласи звучни сигнал током процеса припреме, користите алате отпорне на топлоту да једном окренете храну или пажљиво благо протресете храну у корпи за пржење.

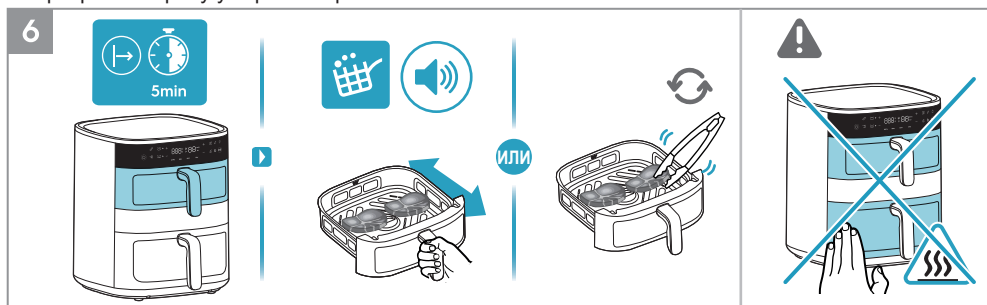

6. Потом, горња корпа са краћим временом ће почети са припремом. Када се икона “Подсетник за протресање” укључи и огласи звучни сигнал током процеса припреме, користите алате отпорне на топлоту да једном окренете храну или пажљиво благо протресете храну у корпи за пржење.

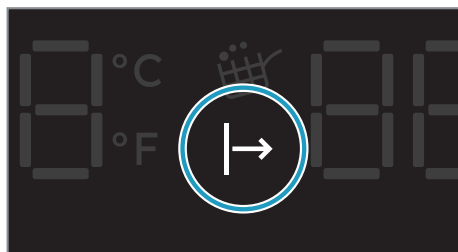

Индикатор чекања на припрему

Када је активирана “Функција завршетка синхронизације”, корпа са краћим временом припреме ће сачекати са припремом док корпа са дужијим временом припреме не почне са припремом неко време, како би обе корпе могле да заврше припрему истовремено. За то време, “индикатор чекања на припрему” ће светлети док припрема не почне.

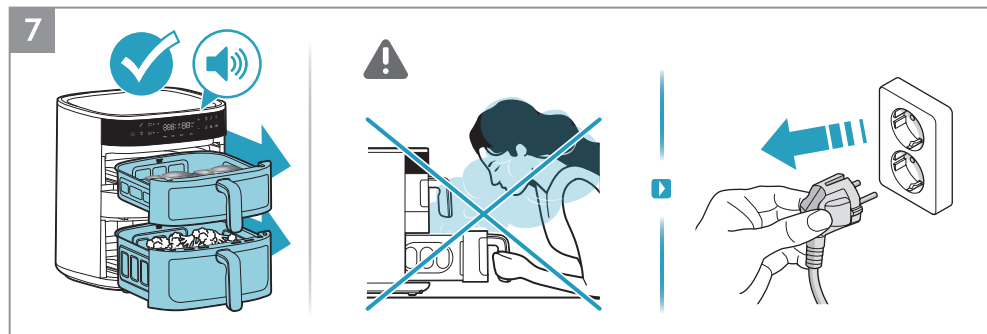

7. По завршетку припреме, уређај ће се огласити звучним сигналом. Искључите уређај из струје након употребе.

Чишћење

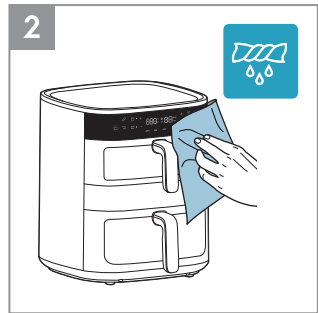
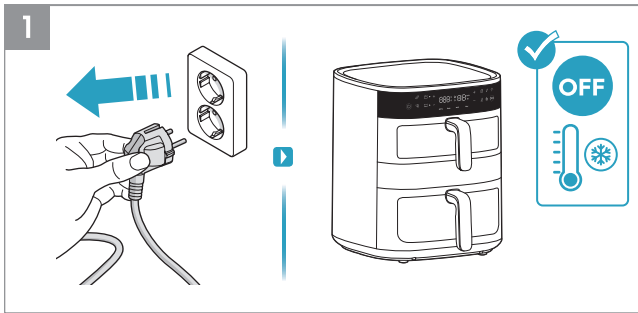

1. Увек искључите уређај из струје и сачекајте да се охлади пре чишћења.
2. Обришите спољашњост уређаја меком крпом.

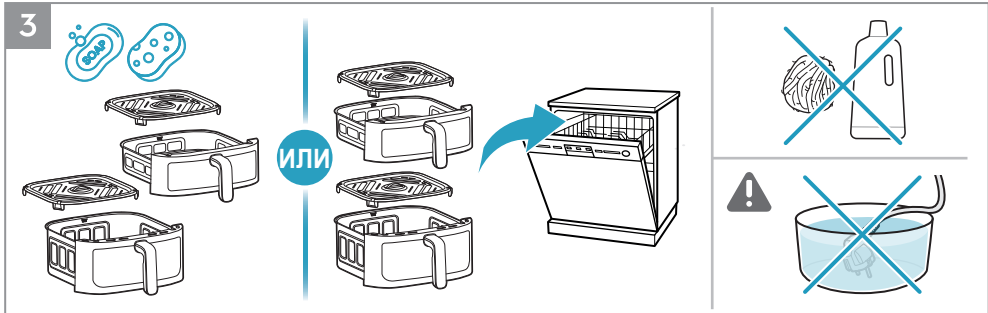

3. Очистите посуду и решетку топлим водом и детерџентом за судове или их ставите у машину за прање судова.

НАПОМЕНА: Избегавајте употребу абразивних средстава за чишћење или металних алата како бисте заштитили нелепљиви премаз.

ОПРЕЗ: Никада не потапајте производ, његов кабл или утикач у воду или било коју другу течност.

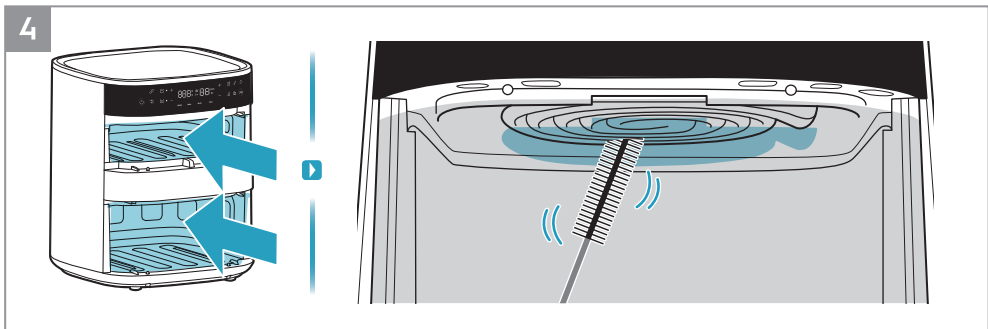











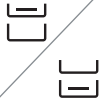

















































4. Очистите грејни елемент четком за чишћење.

НАПОМЕНА: Уверите се да је уређај потпуно охлађен пре чишћења грејног елемента.

EN
BG
CZ
DE
DK
EE
FI
FR
GR
HR
HU
IT
LT
LV
NO
NL
PL
PT
RO
RU
SE
SI
SK
SR
TR
UA
ES
GE
AL

Водич за припрему

							
AirFry	7mm/10mm 	 4 л	400 г	180°C	18 мин		
		 7 л	400 г	180°C	18 мин		
AirFry		 4 л	400 г	170°C	8 мин		
		 7 л	400 г	170°C	10 мин		
AirFry		 4 л	400 г / 2 ком	140°C	15 мин		
		 7 л	400 г / 2 ком	140°C	15 мин		
AirFry		 4 л	1000 г / 8 ком	180°C	28 мин		
		 7 л	1000 г / 8 ком	180°C	28 мин		
AirFry		 4 л	400 г / 2 ком	200°C	10 мин		
		 7 л	400 г / 2 ком	200°C	10 мин		
AirFry		 4 л	220 г / 6inches	160°C	12 мин		
		 7 л	220 г / 6inches	160°C	14 мин		

Recipe							
AirFry		 7 л	1200 г	180°C	55 мин		
AirFry		 7 л	400 г /9 ком	160°C	20 мин		
Grill		 4 л	180 г /4 ком	180°C	8 мин		
		 7 л	180 г /4 ком	180°C	9 мин		
Dry		 4 л	180 г	80°C	3 сата		
		 7 л	180 г	80°C	3 сата		
Dry		 4 л	200 г	80°C	3 сата		
		 7 л	200 г	80°C	3 сата		

- EN
- BG
- CZ
- DE
- DK
- EE
- FI
- FR
- GR
- HR
- HU
- IT
- LT
- LV
- NO
- NL
- PL
- PT
- RO
- RU
- SE
- SI
- SK
- SR**
- TR
- UA
- ES
- GE
- AL

Шта урадити ако ...

Проблем	Проверите да ли ...
Не можете да активирате и ли користите уређај.	<ul style="list-style-type: none"> Уређај је исправно повезан на електричну мрежу . Корпе су у исправном положају . Уверите се да су потпуно у вучени у уређај да би се омогућило напајање електричном енергијом . Време припреме је подешено .
Не можете да убаците корп у уређај.	<ul style="list-style-type: none"> Корпа је напуњена преко свог максималног капацитета . Корпа је правилно постављена . Мора да кликне када је поставите у уређај . Испод корпе се налази предмет због којег не може правилно да се увуче .
Из уређаја излази бели дим .	<ul style="list-style-type: none"> Храна коју припремате је превише масна . Корпа , решетка и грејни елемент су чисти .
Дисплеј приказује E1	<ul style="list-style-type: none"> Отворено коло горње корпе .
Дисплеј приказује E2	<ul style="list-style-type: none"> Кратки спој горње корпе .
Дисплеј приказује E3	<ul style="list-style-type: none"> Отворено коло доње корпе .
Дисплеј приказује E4	<ul style="list-style-type: none"> Кратки спој доње корпе .
Дисплеј приказује E5	<ul style="list-style-type: none"> Грешка у комуникацији са контролном плочом .
Дисплеј приказује E6	<ul style="list-style-type: none"> Грешка у комуникацији са напајањем .

* Уколико дисплеј приказује кодове грешака , уређај мора поправити сервисни центар .

Технички подаци

Производ	Фритеза на врућ ваздух
Модел	EAFD11B
Напон (V~)	220 V ~ 240 V
Снага (W)	2700 W
Фреквенција (Hz)	50 ~ 60 Hz
Капацитет	4 л + 7 л



Electrolux

Kullanım Kılavuzu

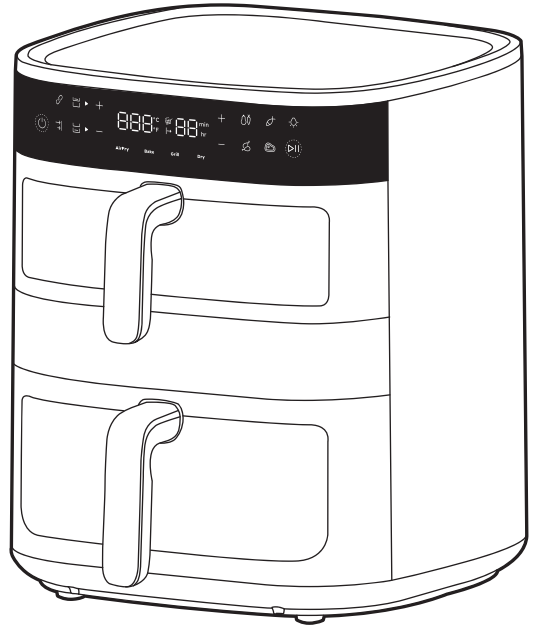

800 Air Fryer Dual

Genel Bakış

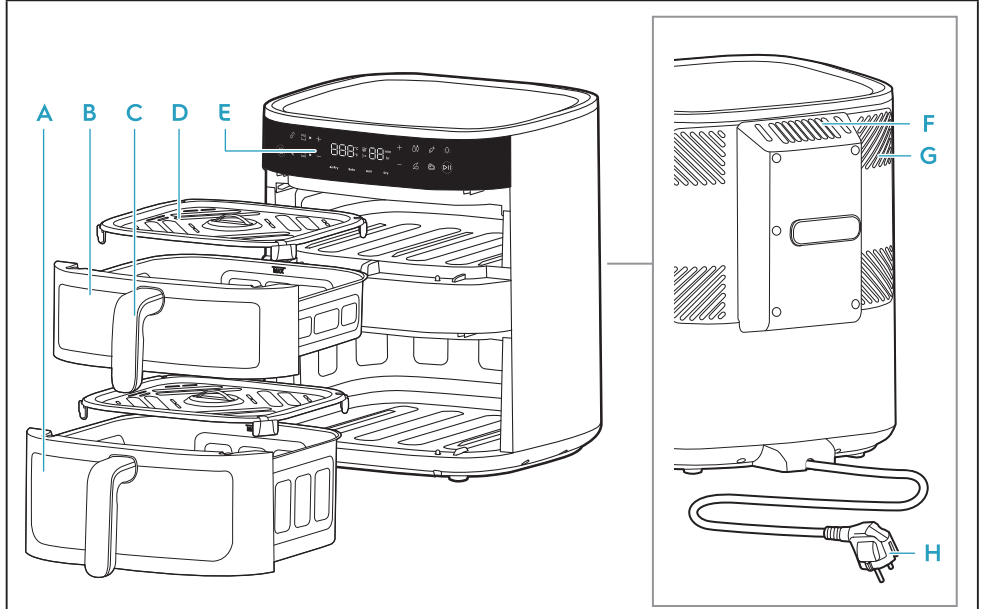

- | | | | |
|------------------|------------------|------------------|-------------------|
| A Alt sepet (7L) | C Sepet tutacağı | E Kontrol paneli | G Soğutma sistemi |
| B Üst sepet (4L) | D Izgara | F Hava çıkışı | H Ana kablo |

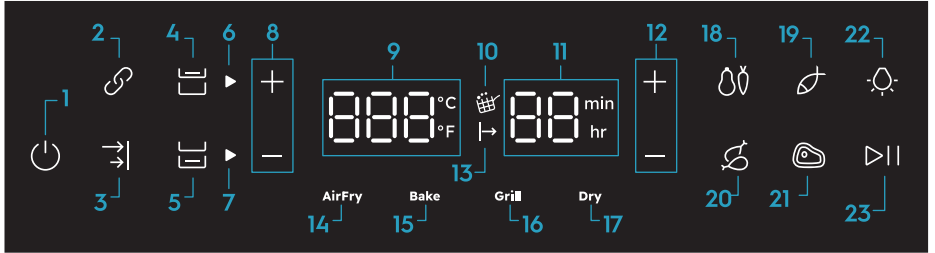

- | | | | |
|-------------------------------|---|--------------------------|------------------------|
| 1. Açma/Kapama | 8. Sıcaklık kontrolü | 12. Zaman kontrolü | 18. Sebzeler |
| 2. Bağlantı işlevi | 9. Sıcaklık göstergesi (40-200°C) | 13. Pişirme için bekleme | 19. Balık |
| 3. Senkronizasyon Sonu işlevi | 10. Çalkalama Hatırlatıcısı | 14. AirFry fonksiyonu | 20. Tavuk |
| 4. Üst sepet kontrolü | 11. Zaman göstergesi (AirFry: 1-99dk, Kurutma: 1-5saat) | 15. Fırınlama fonksiyonu | 21. Biftek |
| 5. Alt sepet kontrolü | | 16. Izgara fonksiyonu | 22. Işık kontrolü |
| 6. Üst sepet göstergesi | | 17. Kurutma fonksiyonu | 23. Çalıştır/ Duraklat |
| 7. Alt sepet göstergesi | | | |

İlk kullanımdan önce

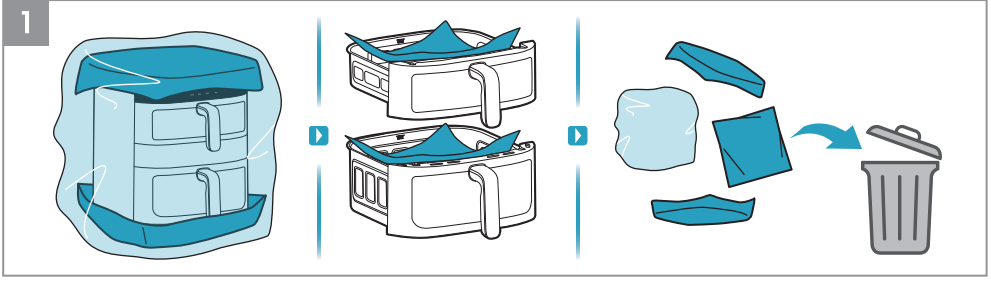

1. Tüm ambalaj ve koruyucu malzemeleri çıkarın.

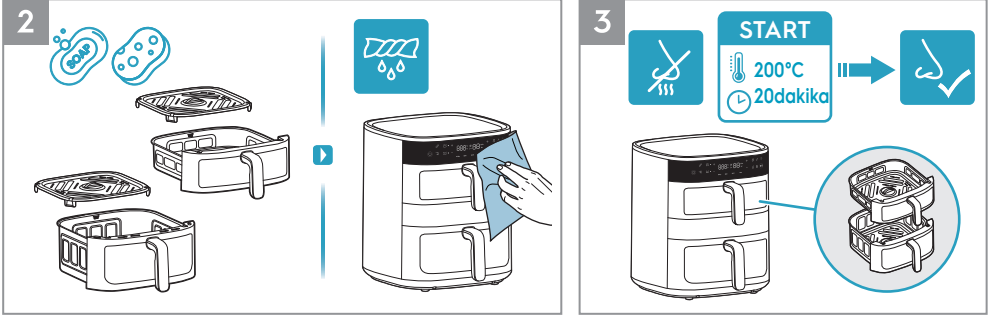

2. Tavayı ve ızgarayı ılık su ve bulaşık deterjanı ile temizleyin. Cihazın içini ve dışını yumuşak bir bezle silin.

3. Yeni bir cihazın ilk birkaç kullanımında koku yayması normaldir. Bunu önlemek için, ilk kullanımdan önce boş air fryer'i 200 °C'de 20 dakika çalıştırın.



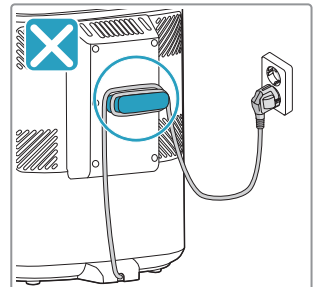
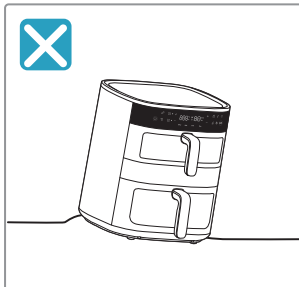
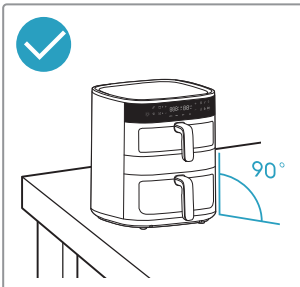
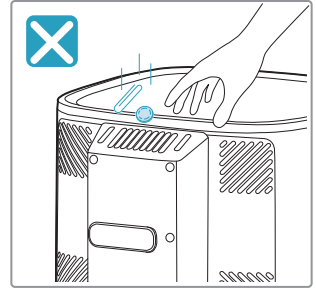
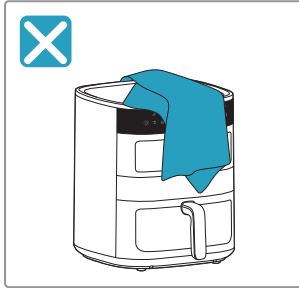
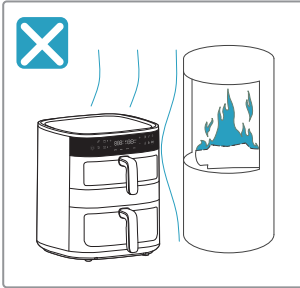



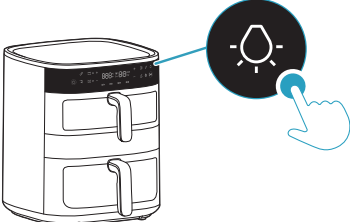
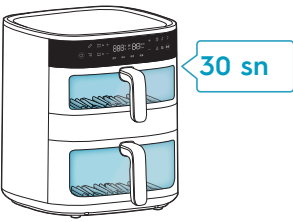
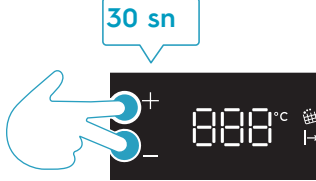
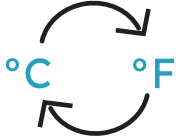



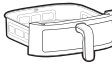

! Güvenlik önlemleri









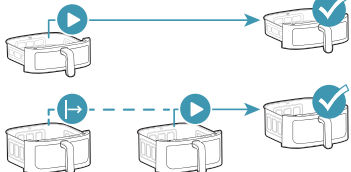



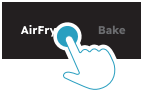



Aydınlatma kontrolü ve sıcaklık ölçeği dönüştürme

 <p>Aydınlatma kontrolü</p>		
<p>°C/°F</p> <p>Sıcaklık ölçeği dönüştürme</p>		

Sepet seçimi

	 <p>4L</p>	 <p>7L</p>	
 <p>Üst Sepet</p>			
 <p>Alt Sepet</p>			
 <p>Bağlantı işlevi</p>			
 <p>Senkronizasyon sonu işlevi</p>			

Önceden ayarlanmış işlevler

 AirFry					
AirFry	180°C	15dakika	60-200°C	1-99dakika	
	170°C	10dakika	60-200°C	1-99dakika	
	140°C	15dakika	60-200°C	1-99dakika	
	180°C	30dakika	60-200°C	1-99dakika	
	200°C	10dakika	60-200°C	1-99dakika	
Bake	170°C	15dakika	60-200°C	1-99dakika	
Grill	200°C	5dakika	60-200°C	1-99dakika	
Dry	80°C	5h	40-80°C	1-5h	

Pişirmeden önce

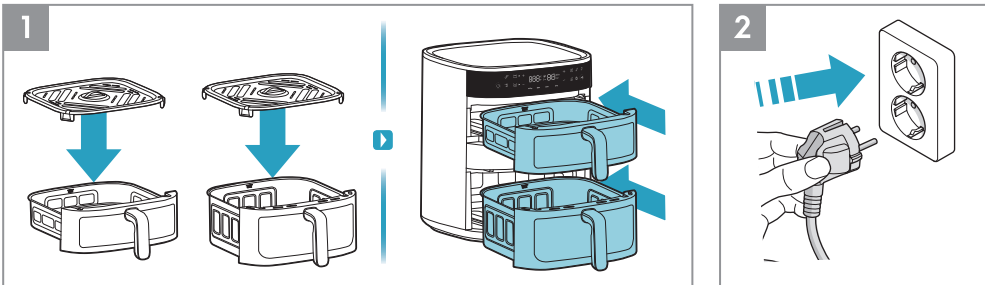

Nasıl kullanılır - Tek sepet

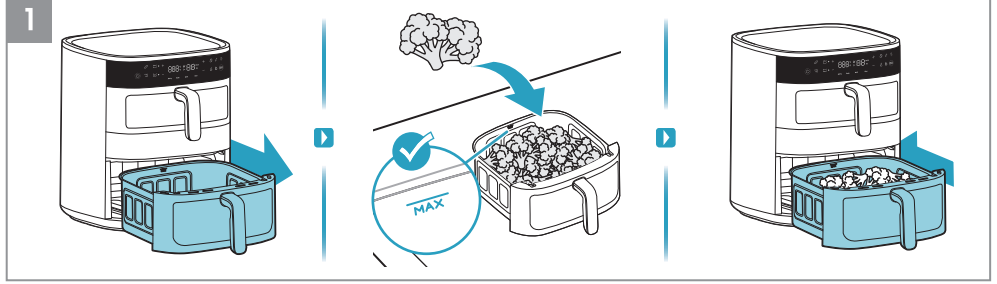

1. Bir sepeti çekip sabit bir yüzeye yerleştirin, yiyecekleri sepete koyun ve "MAX" kapasite göstergesine dikkat edin. Ardından yiyeceklerin bulunduğu sepeti tamamen cihaza geri itin.



2. Açma/Kapama düğmesine basın. Önce yiyeceklerin bulunduğu sepeti seçin. Ardından istediğiniz pişirme yöntemini seçin, örneğin Air Fry işlevi. Zamanı ve sıcaklığı zevkinize göre ayarlayın veya önceden ayarlanmış tariflerden birini seçin, örneğin; Sebze. Son olarak, Çalıştır/Duraklat düğmesine basın.

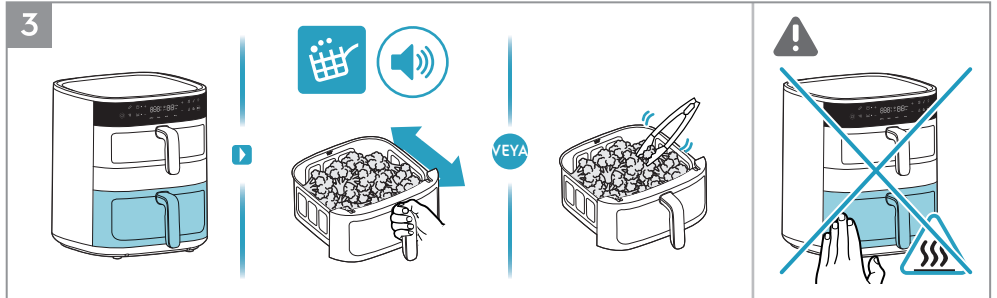

3. Pişirme işlemi sırasında "Çalkalama Hatırlatıcısı" simgesi yanıp sönmeye ve bip sesi çıkarmaya başladığında, ısıya dayanıklı aletler kullanarak yiyeceği bir kez çevirin veya kızartma sepetini dikkatlice hafifçe sallayın.

⚠ **DİKKAT:** Yiyeceklerin sıçramasını ve yanıklara neden olmasını önlemek için kızartma sepetini şiddetli bir şekilde sallamayın.

⚠ **DİKKAT:** Cihaz kullanımdayken sıcak yüzeylere dikkat edin.

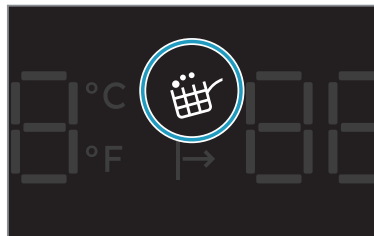

Çalkalama Hatırlatıcısı

"Çalkalama Hatırlatıcısı", Air Fry işlevi ve sebzeler, balık, tavuk budu ve biftek gibi önceden ayarlanmış tarifler sırasında etkinleştirilir.

Yiyeceklerinizi çalkalamak veya çevirmek gerektiğinde, "Çalkalama Hatırlatıcısı" simgesi yanar ve bir dakika boyunca yanıp sönerken, bip sesi üç kez tekrar eder.

"Çalkalama Hatırlatıcısı" zorunlu değildir, bu nedenle yiyecekler çevrilmez veya çalkalanmazsa pişirme işlemi normal şekilde devam eder.



4. Pişirme süresi sonunda cihaz bip sesi çıkarır. Sepeti dikkatlice çıkarın ve ısıya dayanıklı bir yüzeye yerleştirin. Kullanımdan sonra cihazın fişini prizden çekin.

⚠ **DİKKAT:** Pişirme işleminin ortasında veya sonunda sepet açıldığında sepette sıcak buhar çıkabilir. Sepeti açarken yüzünüzü, kollarınızı ve ellerinizi buhardan uzak tutun.

Nasıl kullanılır - Üst + Alt sepet

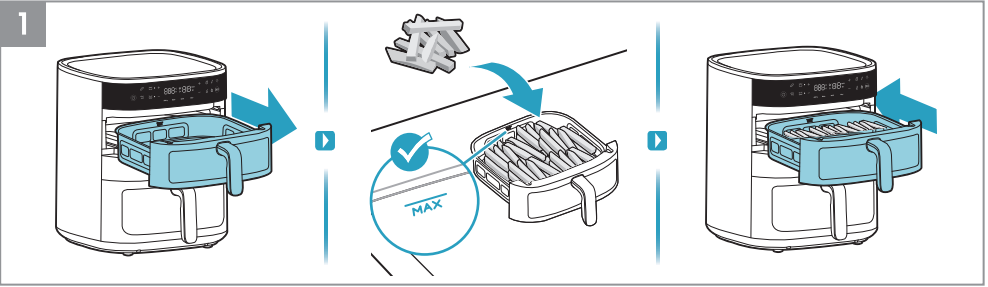

1. Öncelikle, üst sepeti çekip çıkarın ve yiyecekleri sepete koyun, örneğin; patates kızartması.

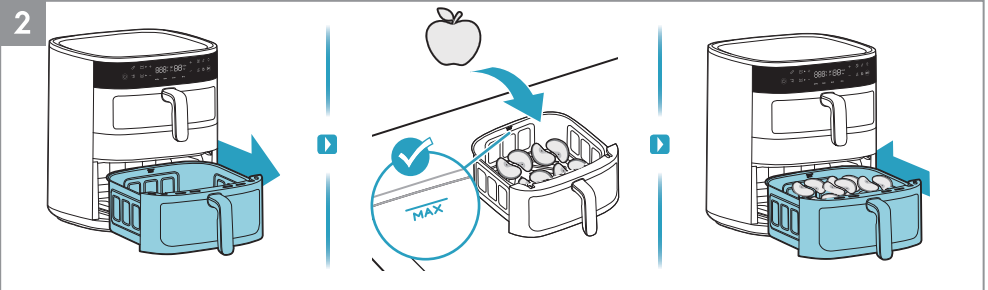

2. Ardından, alt sepeti çekip çıkarın ve yiyecekleri sepete koyun, örneğin; elma dilimleri.



3. Açma/Kapama düğmesine basın. Önce üst sepeti seçin. Ardından istediğiniz pişirme yöntemini seçin, örneğin Air Fry işlevi. Zamanı ve sıcaklığı zevkinize göre ayarlayın veya önceden ayarlanmış tariflerden birini seçin, örneğin; Sebze. Son olarak, Çalıştır/Duraklat düğmesine basın.



4. İkinci olarak, alt sepeti seçin. Ardından istediğiniz pişirme yöntemini seçin, örneğin; Kurutma fonksiyonu. Zamanı ve sıcaklığı zevkinize göre ayarlayın. Son olarak, Çalıştır/Duraklat düğmesine basın.

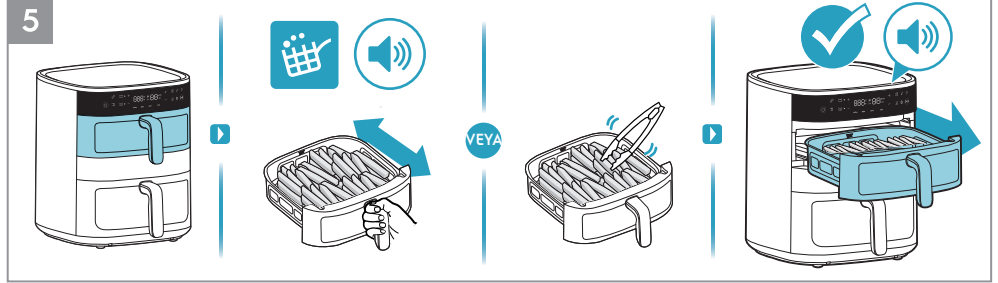

5. Pişirme işlemi sırasında "Çalkalama Hatırlatıcısı" simgesi yanıp sönmeye ve bip sesi çıkarmaya başladığında, ısıya dayanıklı aletler kullanarak yiyeceği bir kez çevirin veya kızartma sepetini dikkatlice hafifçe sallayın. Üst sepetin pişirme süresi sona erdiğinde, cihaz bir bip sesi çıkaracaktır.

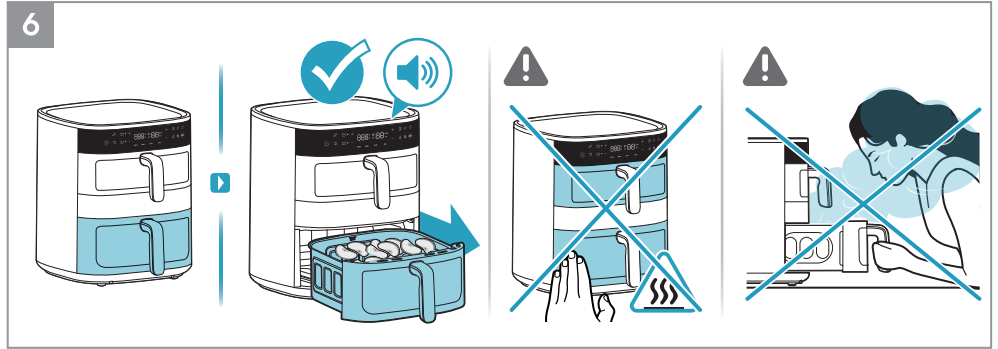

6. Alt sepetin pişirme süresi sona erdiğinde, cihaz bir bip sesi çıkaracaktır.

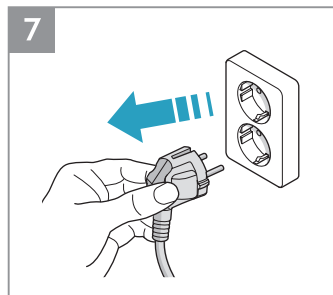

7. Kullanımdan sonra cihazın fişini prizden çekin.

Nasıl kullanılır - Bağlantı işlevi

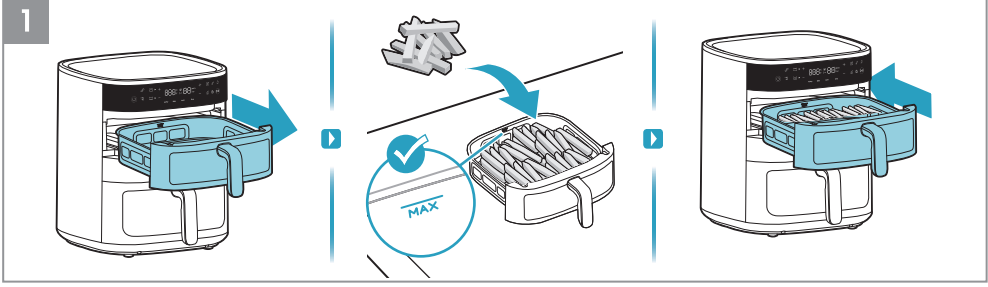

1. Öncelikle, üst sepeti çekip çıkarın ve yiyecekleri sepete koyun, örneğin; patates kızartması.

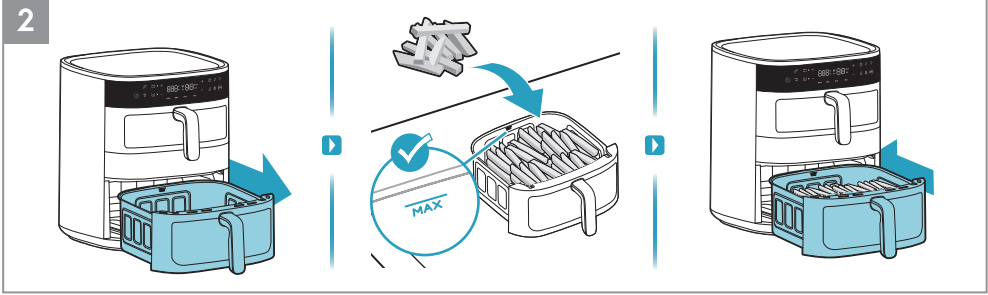

2. İkinci olarak, alt sepeti dışarı çekin ve yiyecekleri sepete koyun, örneğin; patates kızartması.



3. Açma/Kapama düğmesine basın. Öncelikle bağlantı işlevini seçin. Ardından istediğiniz pişirme yöntemini seçin, örneğin Air Fry işlevi. Zamanı ve sıcaklığı zevkinize göre ayarlayın veya önceden ayarlanmış tariflerden birini seçin. Son olarak, Çalıştır/Duraklat düğmesine basın.

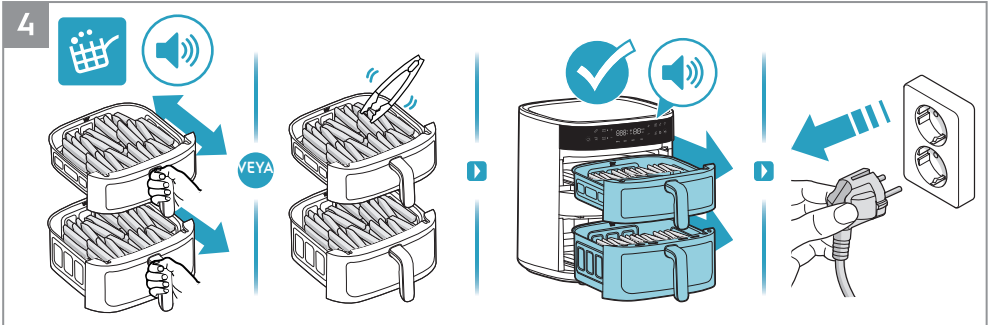

4. Pişirme işlemi sırasında "Çalkalama Hatırlatıcısı" simgesi yanıp sönmeye ve bip sesi çıkarmaya başladığında, ısıya dayanıklı aletler kullanarak yiyeceği bir kez çevirin veya kızartma sepetini dikkatlice hafifçe sallayın. Pişirme süresi sonunda cihaz bip sesi çıkarır. Kullanımdan sonra cihazın fişini prizden çekin.

Nasıl kullanılır - Senkronizasyon Sonu işlevi

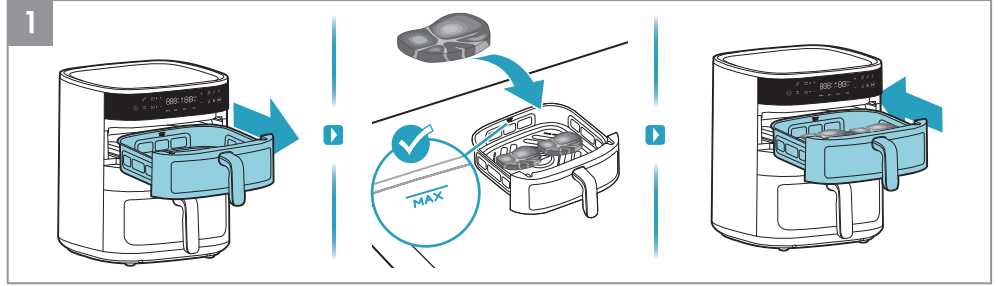

1. İlk olarak, üst sepeti dışarı çekin ve yiyeceği sepete koyun, örneğin; biftek.

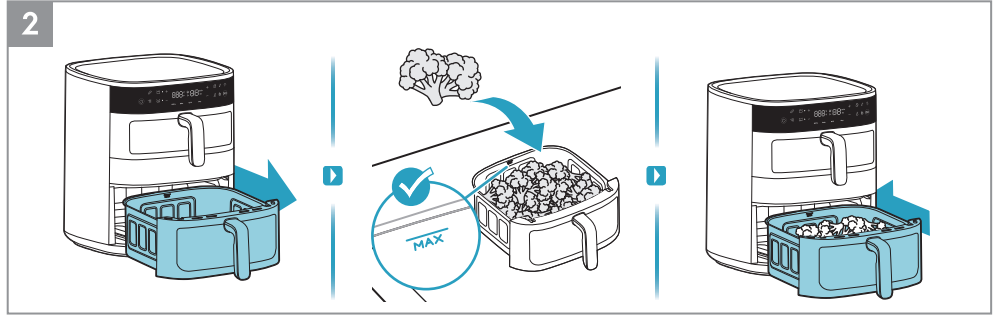

2. İkinci olarak, alt sepeti dışarı çekin ve yiyeceği sepete koyun, örneğin; brokoli.



3. Açma/Kapama düğmesine basın. Senkronizasyon Sonu işlevini seçin. Önce üst sepeti seçin, ardından istediğiniz pişirme yöntemini seçin, örneğin; Air Fry işlevi. Zamanı ve sıcaklığı zevkinize göre ayarlayın veya önceden ayarlanmış tariflerden birini seçin, örneğin; Biftek.

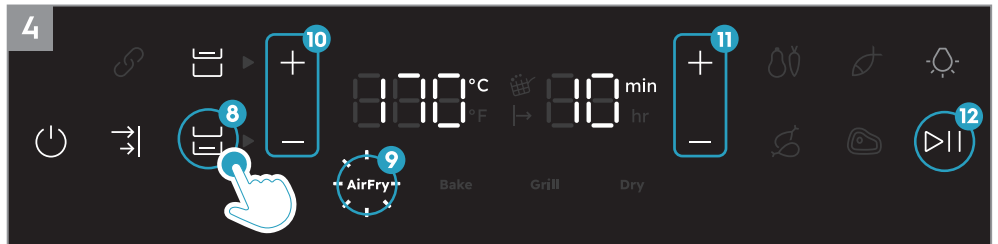

4. Ardından alt sepeti seçin, istediğiniz pişirme yöntemini seçin, örneğin Air Fry işlevi. Zamanı ve sıcaklığı zevkinize göre ayarlayın veya önceden ayarlanmış tariflerden birini seçin. Son olarak, Çalıştır/Duraklat düğmesine basın.

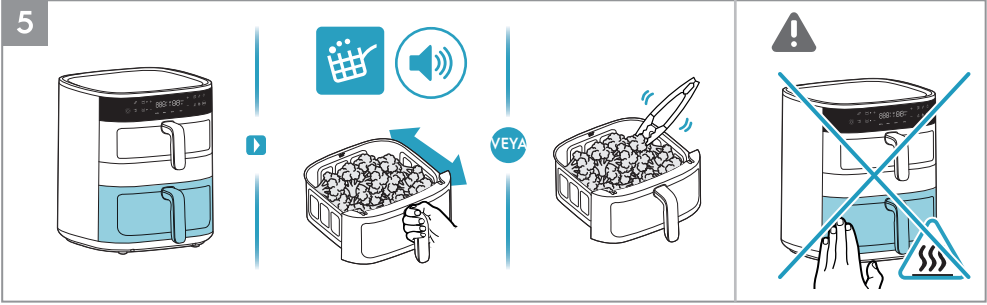

5. Öncelikle, pişirme süresi daha uzun olan alt sepet öncelikli olarak pişirilecektir. Pişirme işlemi sırasında "Çalkalama Hatırlatıcısı" simgesi yanıp sönmeye ve bip sesi çıkarmaya başladığında, ısıya dayanıklı aletler kullanarak yiyeceği bir kez çevirin veya kızartma sepetini dikkatlice hafifçe sallayın.

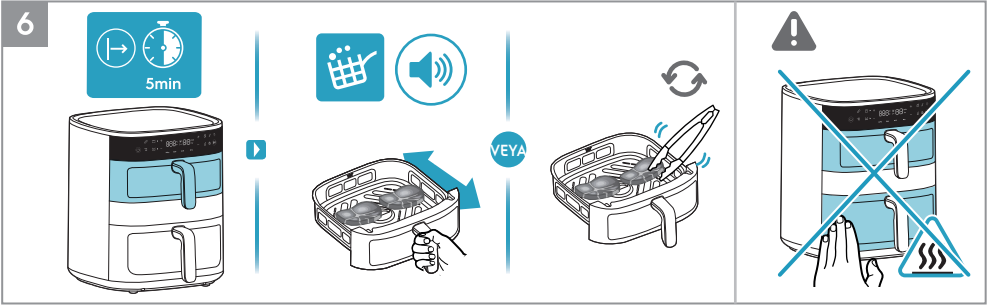

6. İkinci olarak, ayar süresi daha kısa olan üst sepet pişirmeye başlayacaktır. Pişirme işlemi sırasında "Çalkalama Hatırlatıcısı" simgesi yanıp sönmeye ve bip sesi çıkarmaya başladığında, ısıya dayanıklı aletler kullanarak yiyeceği bir kez çevirin veya kızartma sepetini dikkatlice hafifçe sallayın.

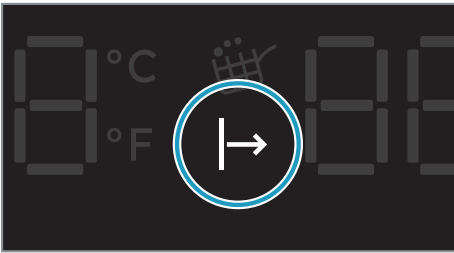

Pişirme için bekleme göstergesi

"Senkronizasyon sonu işlevi" etkinleştirildiğinde, pişirme süresi daha kısa olan sepet, pişirme süresi daha uzun olan sepet bir süre pişirildikten sonra pişirmeye başlar, böylece her iki sepet de aynı anda pişirmeyi tamamlayabilir. Bu süre boyunca, pişirme başlayana kadar "pişirme için bekleme göstergesi" yanar.



7. Pişirme süresi sonunda cihaz bip sesi çıkarır. Kullanımdan sonra cihazın fişini prizden çekin.

Temizlik

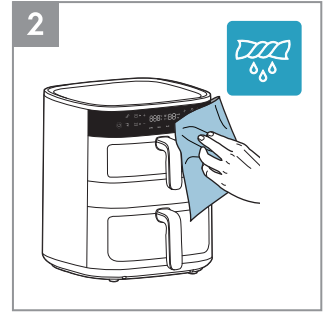
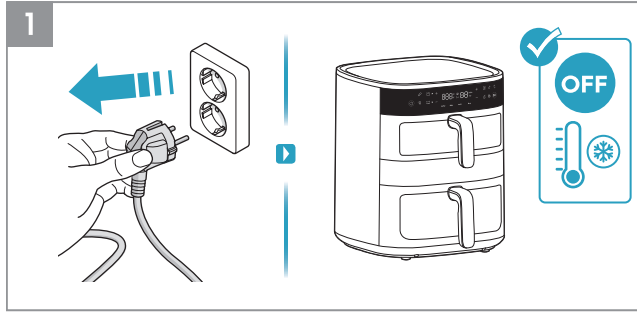

1. Temizlemeden önce daima cihazın fişini çekin ve soğumasını bekleyin.
2. Cihazın dışını yumuşak bir bezle silin.

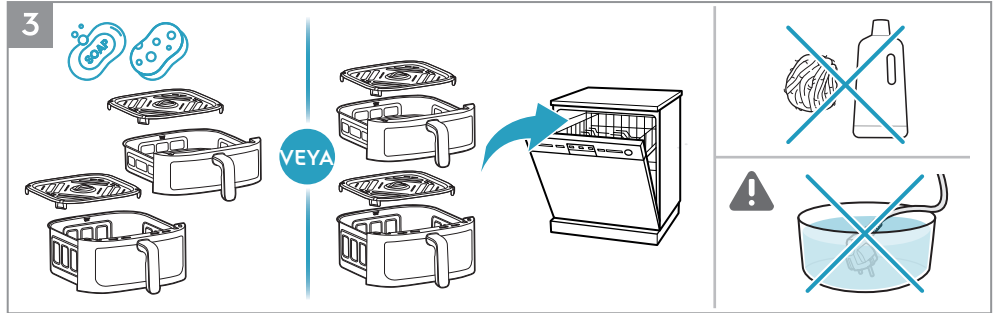

3. Tavayı ve ızgarayı ılık su ve bulaşık deterjanı ile temizleyin veya bulaşık makinesine koyun.

▲NOT: Yapışmaz kaplamayı korumak için aşındırıcı temizlik ürünleri veya metal aletler kullanmaktan kaçının.



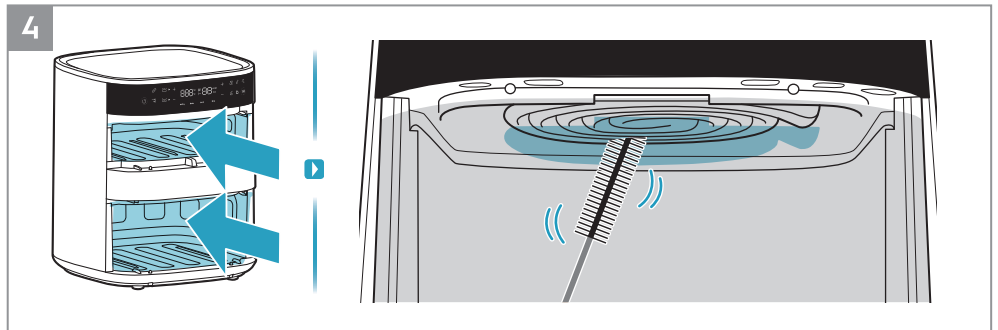



































DİKKAT: Ürünü, kablosunu veya fişini asla suya veya başka bir sıvıya batırmayın.



4. Isıtma elemanını temizleme fırçası ile temizleyin.











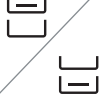











NOT: Isıtma elemanını temizlemeden önce cihazın tamamen soğuduğundan emin olun.

Piştirme Kılavuzu

							
AirFry	7mm/10mm 	 4L	400g	180°C	18dakika		
		 7L	400g	180°C	18dakika		
AirFry		 4L	400g	170°C	8dakika		
		 7L	400g	170°C	10dakika		
AirFry		 4L	400g/2adet	140°C	15dakika		
		 7L	400g/2adet	140°C	15dakika		
AirFry		 4L	1000g/8adet	180°C	28dakika		
		 7L	1000g/8adet	180°C	28dakika		
AirFry		 4L	400g/2adet	200°C	10dakika		
		 7L	400g/2adet	200°C	10dakika		
AirFry		 4L	220g/6inç	160°C	12dakika		
		 7L	220g/6inç	160°C	14dakika		

EN
BG
CZ
DE
DK
EE
FI
FR
GR
HR
HU
IT
LT
LV
NO
NL
PL
PT
RO
RU
SE
SI
SK
SR
TR
UA
ES
GE
AL

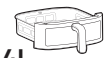
EN
BG
CZ
DE
DK
EE
FI
FR
GR
HR
HU
IT
LT
LV
NO
NL
PL
PT
RO
RU
SE
SI
SK
SR
TR
UA
ES
GE
AL

Recipe							
AirFry		 7L	1200g	180°C	55dakika		
AirFry		 7L	400g/9adet	160°C	20dakika		
Grill		 4L	180g/4adet	180°C	8dakika		
		 7L	180g/4adet	180°C	9dakika		
Dry		 4L	180g	80°C	3saat		
		 7L	180g	80°C	3saat		
Dry		 4L	200g	80°C	3saat		
		 7L	200g	80°C	3saat		

Şu sorunda ne yapmalı...

Sorun	Kontrol edin...
Cihazı çalıştıramaz veya kullanamazsınız.	<ul style="list-style-type: none">• Cihaz elektrik kaynağına doğru şekilde bağlanmıştır.• Sepetler doğru konumdadır. Elektrik kaynağını etkinleştirmek için sepetlerin cihaza tamamen itildiğinden emin olun.• Pişirme süresi ayarlanmıştır.
Sepeti cihaza kaydıramazsınız.	<ul style="list-style-type: none">• Sepet maksimum kapasitesinin üzerinde doldurulmuştur.• Sepet doğru şekilde yerleştirilmiştir. Üniteye yerleştirdiğinizde yerine oturması gerekir.• Sepetin altında, sepetin düzgün bir şekilde kapanmasını engelleyen bir nesne var.
Cihazdan beyaz duman çıkıyor.	<ul style="list-style-type: none">• Hazırladığınız yiyecekler çok yağlı.• Sepet, ızgara ve ısıtma elemanı temiz.
Ekran E1 yazısı görünüyor.	•Üst sepet açık devre.
Ekran E2 yazısı görünüyor.	•Üst sepet kısa devre.
Ekran E3 yazısı görünüyor.	•Alt sepet açık devre.
Ekran E4 yazısı görünüyor.	•Alt sepet kısa devre.
Ekran E5 yazısı görünüyor.	•Kontrol PCBA bağlantı hatası.
Ekran E6 yazısı görünüyor.	•Güç PCBA Bağlantı hatası.

* Ekran E1 hatası kodları görüntülenirse, cihaz bir Servis Merkezi tarafından onarılmalıdır.

Teknik Veri

Ürün	Air Fryer
Model	EAFD11B
Voltaj (V-)	220 V ~ 240 V
Güç (W)	2700 W
Frekans (Hz)	50 ~ 60 Hz
Kapasite	4 L + 7 L



Інструкція з експлуатації

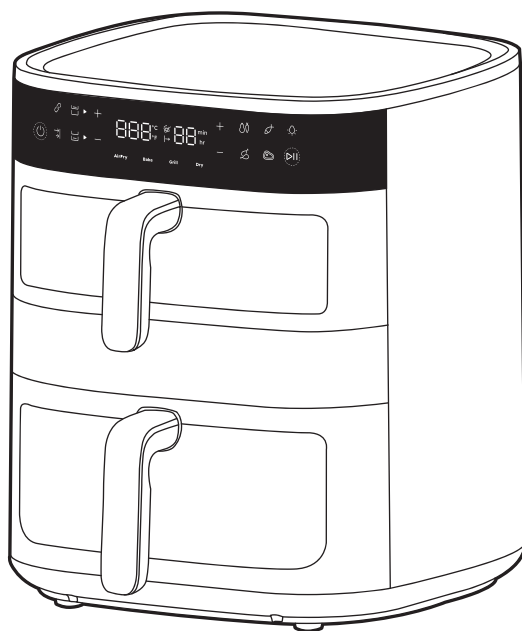

Подвійна аерофритюрниця серії 800

Загальний огляд

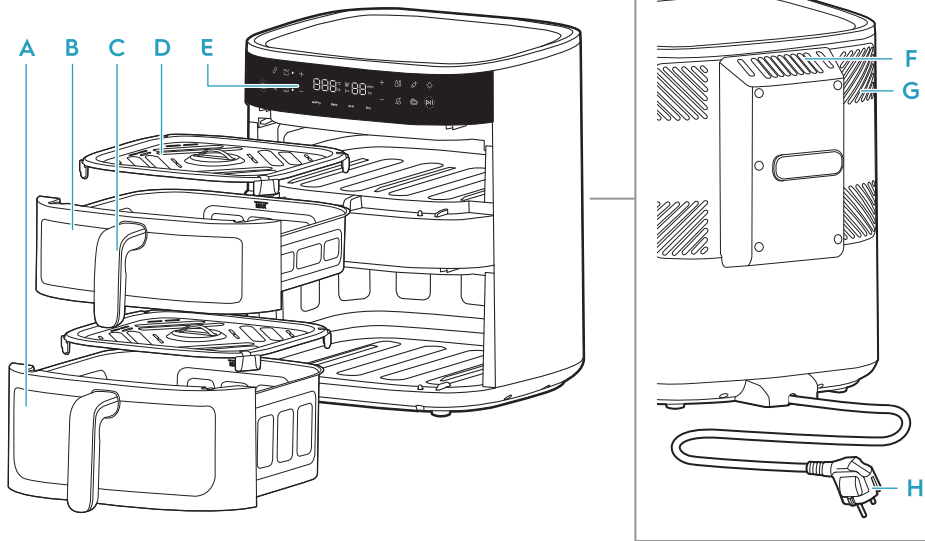

- A** Нижній кошик (7 л) **C** Ручка кошика **E** Панель керування **G** Система охолодження
B Верхній кошик (4 л) **D** Решітка **F** Отвір для виходу повітря **H** Шнур живлення

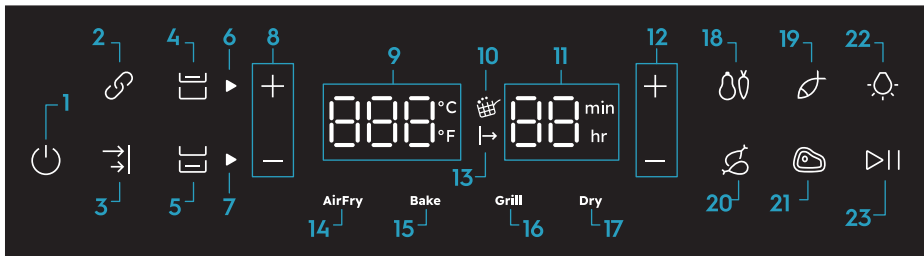

- | | | | |
|--|---|---|------------------------------|
| 1. Увімкнення / вимкнення | 8. Регулювання температури | 12. Налаштування часу | 18. Овочі |
| 2. Функція сполучення | 9. Індикатор температури (40–200 °C) | 13. Очищення приготування | 19. Риба |
| 3. Функція синхронізації закінчення приготування | 10. Нагадування про період нагрівання | 14. Функція повітряного смаження (AirFry) | 20. Курка |
| 4. Управління верхнім кошиком | 11. Індикатор часу (Повітряне смаження: 1–99 хв., Дегідратація: 1–5 год.) | 15. Функція випікання (Bake) | 21. Стейк |
| 5. Управління нижнім кошиком | | 16. Функція гриля (Grill) | 22. Керування підсмажуванням |
| 6. Індикатор верхнього кошика | | 17. Функція сушіння (Dry) | 23. Пуск / Призупинення |
| 7. Індикатор нижнього кошика | | | |

Перед першим використанням

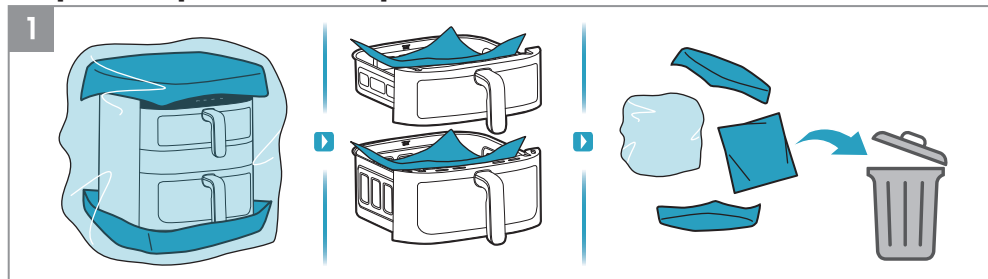

1. Видал іть всю упаковку та захисний матер і ал .

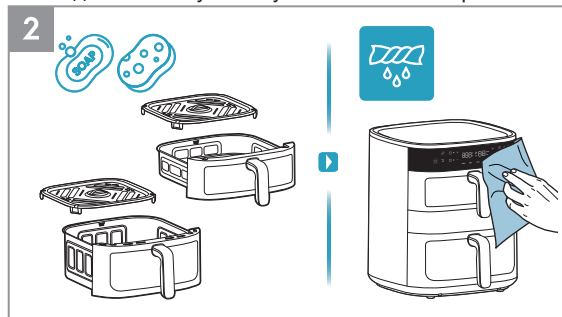

2. Вимийте кошик і реш і тку теплою водою з додаванням засобу для миття посуду . Протр іть ть в нутр і шню і зовн і шню поверхн і пристрою м'якою тканиною .

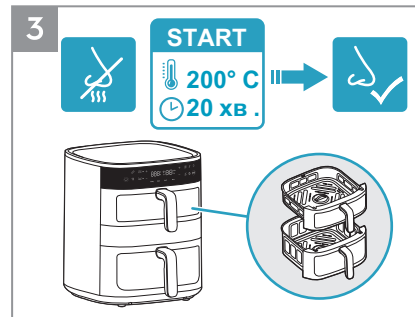



3. П і д час перших дек і льох використань нового пристрою поява запах і в є нормальним яви щем . Щоб уникнути цього , перед першим використанням прогр і йте порожню аерофритюрницю при температур і 200 ° C протягом 20 хвилин .

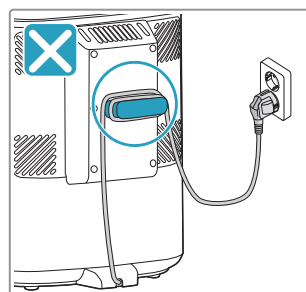
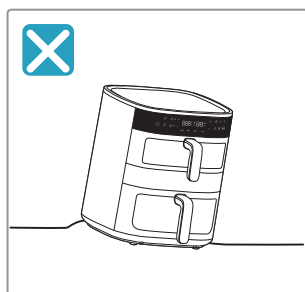
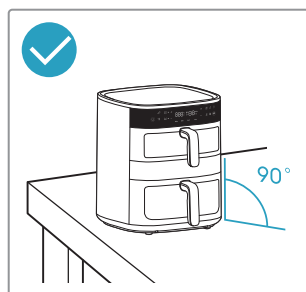
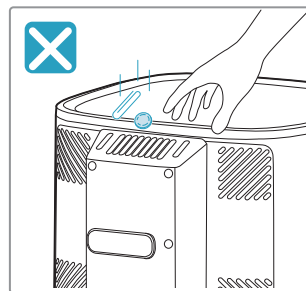
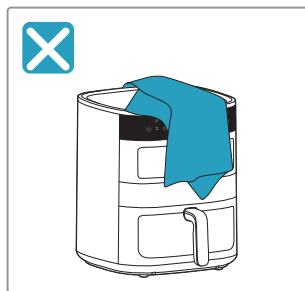
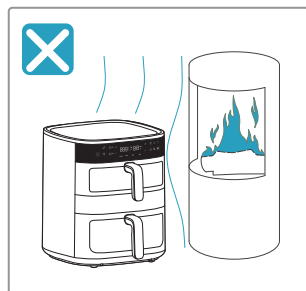



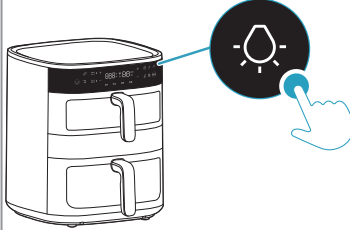
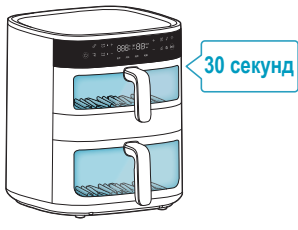

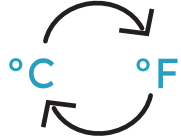



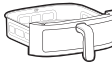

⚠ Заходи безпеки



Керування підсвічуванням і чутливістю шкали температур

 <p>Керування підсвічуванням</p>		
 <p>Перемикач шкали температур</p>		

Вибір кошика

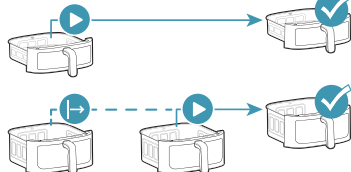
	 <p>4 л</p>	 <p>7 л</p>	
 <p>Верхній кошик</p>			
 <p>Нижній кошик</p>			
 <p>Функція сполучення</p>			
 <p>Функція синхронізації запису</p>			

- EN
- BG
- CZ
- DE
- DK
- EE
- FI
- FR
- GR
- HR
- HU
- IT
- LT
- LV
- NO
- NL
- PL
- PT
- RO
- RU
- SE
- SI
- SK
- SR
- TR
- UA**
- ES
- GE
- AL

EN
BG
CZ
DE
DK
EE
FI
FR
GR
HR
HU
IT
LT
LV
NO
NL
PL
PT
RO
RU
SE
SI
SK
SR
TR
UA
ES
GE
AL

Попередньо встановлені функції

					
AirFry	180° C	15 хв .	60~200° C	1~99 хв .	
	170° C	10 хв .	60~200° C	1~99 хв .	
	140° C	15 хв .	60~200° C	1~99 хв .	
	180° C	30 хв .	60~200° C	1~99 хв .	
	200° C	10 хв .	60~200° C	1~99 хв .	
Bake	170° C	15 хв .	60~200° C	1~99 хв .	
Grill	200° C	5 хв .	60~200° C	1~99 хв .	
Dry	80° C	5 год .	40~80° C	1~5 год .	

Перед приготуванням

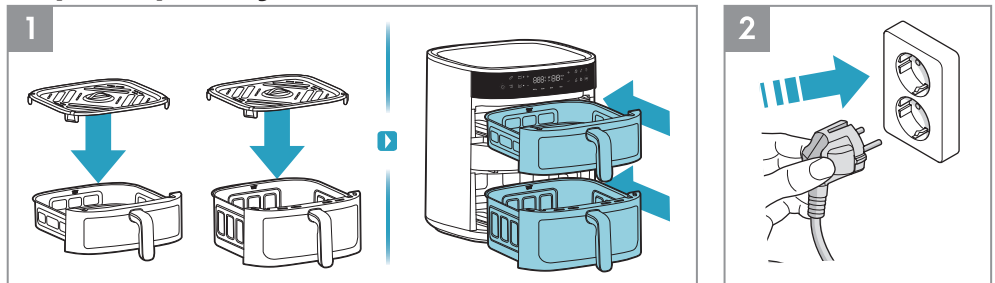

1. Перед кожним приготуванням помістіть решітку в кошик (термомітку силіконову підставку решітки знайти не потрібно) і повністю вставте кошик в пристрій.
2. Вставте вилку шнура живлення в розетку.

Порядок використання — ОДИН КОШИК

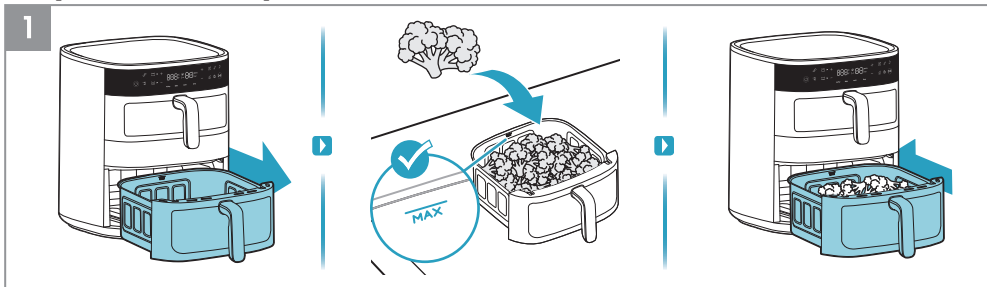

1. Витягніть один кошик і поставте його на стійку поверхню, покладіть у кошик продукти, не перевищуючи максимальну місткість, позначену маркуванням "MAX.". Потім повністю закрийте кошик з продуктами назад у пристрій.



2. Натисніть кнопку увімкнення / вимкнення. Спочатку виберіть кошик з продуктами. Потім виберіть бажаний спосіб приготування, наприклад, функцію "Air Fry" (Повітряне смаження). Налаштуйте час і температуру на свій смак або виберіть один із попередньо встановлених рецептів, наприклад, "Овочі". Нарешті, натисніть кнопку "Пуск / Призупинення".

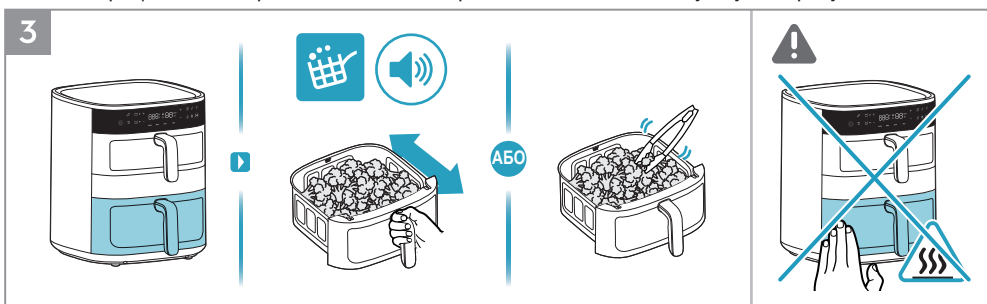

3. Коли під час приготування загориться значок "Нагадування про перемишування" і пролунає звуковий сигнал, переверніть продукти один раз за допомогою термостійких кухонних приладів або обережно злегка струсіть кошик для смаження.

- ⚠ **ОБЕРЕЖНО:** Не струшуйте кошик для смаження, щоб уникнути розбризкування їжі та отримання опіків.
- ⚠ **ОБЕРЕЖНО:** Будьте обережні з гарячими поверхнями, коли пристрій працює.

Нагадування про перемишування

"Нагадування про перемишування" активується під час роботи функції "Air Fry" (Повітряне смаження) та при використанні попередньо встановлених рецептів, таких як "Овочі", "Риба", "Курячі стейки" та "Стейк".

Коли настане час струсіти або перевернути продукти, значок "нагадування про перемишування" загориться і буде блимати протягом однієї хвилини, а звуковий сигнал буде повторюватися три рази. "Нагадування про перемишування" не є обов'язковим до виконання, тому приготування буде продовжуватися як зазвичай, навіть якщо їжа не буде перевертатися або струшуватися.

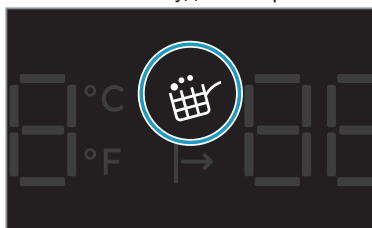



4. Після закінчення часу приготування пристрій подасть звуковий сигнал. Обережно вийміть кошик і поставте його на термостійку поверхню. Після використання відключіть пристрій від мережі.

⚠ ОБЕРЕЖНО : При відкритті кошика в середині або в кінці приготування, з нього може вийти гаряча пара. При відкритті кришки тримайте обличчя, руки і кисті рук подалі від пари.

Порядок використання — верхній + нижній кошик

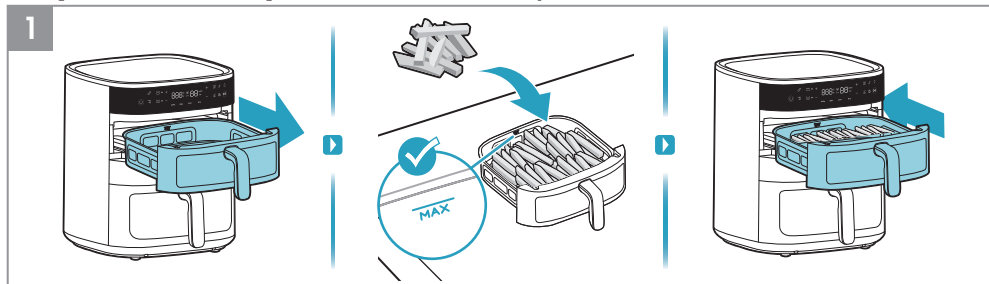

1. Спочатку вийміть верхній кошик і покладіть у нього продукти, наприклад, картоплю фри.

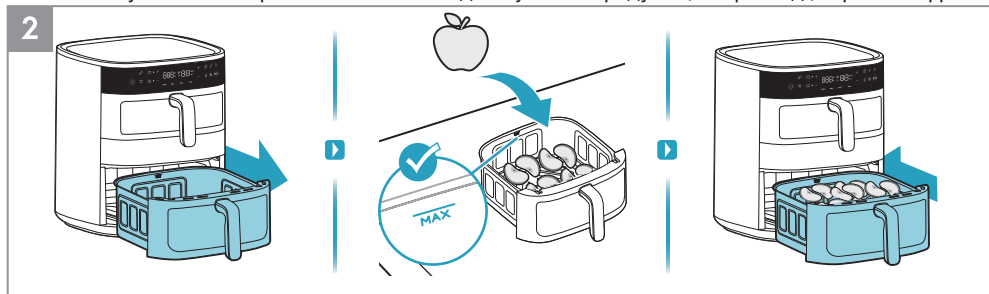

2. Потім вийміть нижній кошик і покладіть у нього продукти, наприклад, скибочки яблук.



3. Натисніть кнопку увімкнення / вимкнення. Спочатку виберіть верхній кошик. Потім виберіть бажаний спосіб приготування, наприклад, функцію "Air Fry" (Повітряне смаження). Налаштуйте час і температуру на свій смак або виберіть один із попередньо встановлених рецептів, наприклад, "Овочі". Нарешті, натисніть кнопку "Пуск / Призупинення".



4. Потім виберіть нижній кошик. Потім виберіть бажаний спосіб приготування, наприклад, функцію "Dry" (Сушка). Налаштуйте час і температуру на свій смак. Нарешті, натисніть кнопку "Пуск / Призупинення".

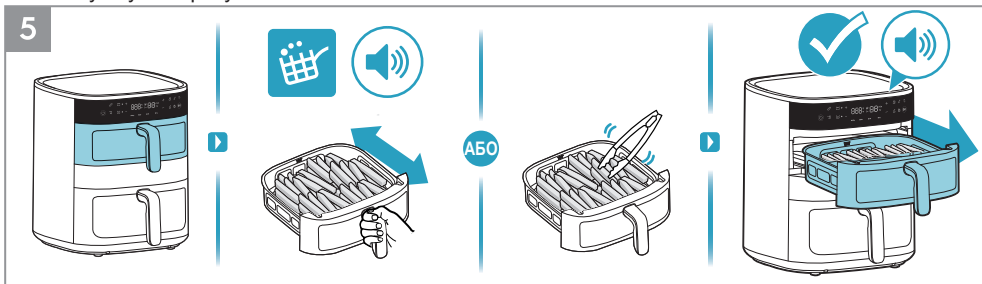

5. Коли під час приготування загориться значок "Нагадування про перемішування" і пролунає звуковий сигнал, переверніть продукти один раз за допомогою термостійких кухонних приладів або обережно злегка струсіть кошик для смаження. Після закінчення часу приготування у верхньому кошику пристрій подасть звуковий сигнал.

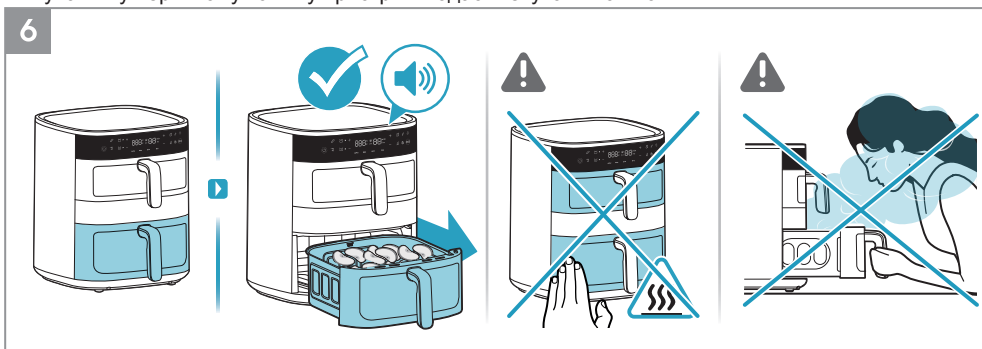

6. Після закінчення часу приготування в нижньому кошику пристрій подасть звуковий сигнал.

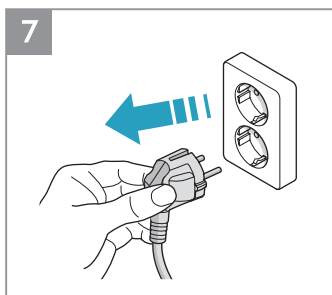

7. Після використання відключіть пристрій від мережі.

EN
BG
CZ
DE
DK
EE
FI
FR
GR
HR
HU
IT
LT
LV
NO
NL
PL
PT
RO
RU
SE
SI
SK
SR
TR
UA
ES
GE
AL

Порядок використання — функція сполучення

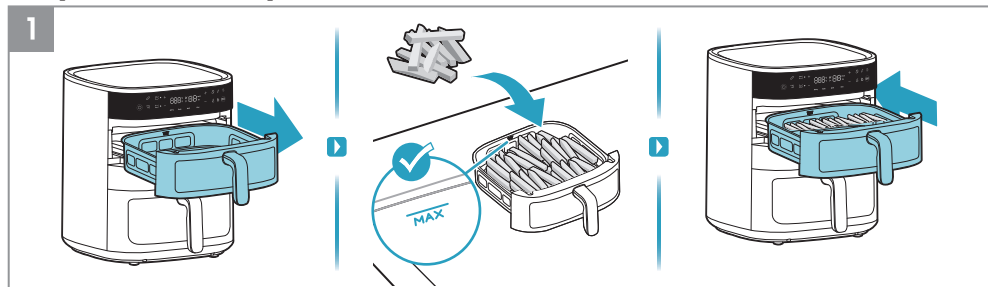

1. Спочатку вийм іть верхн ій кошик і поклад іть у нього продукти , наприклад , картоплю фр і.

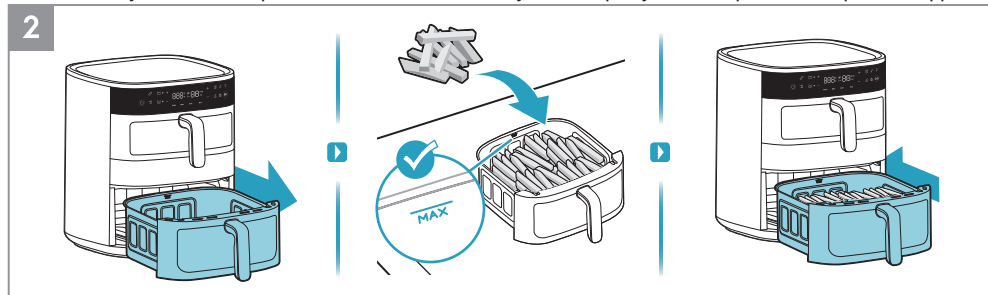

2. Пот і м вийм іть нижн ій кошик і поклад іть у нього продукти , наприклад , картоплю фр і.



3. Натисн іть кнопку ув і мкнення / вимкнення . Спочатку вибер іть функці ю сполучення . Пот і м вибер іть бажаний спос і б приготування , наприклад , функці ю «Air Fry» (Пов ітряне смаження). Налаштуйте час і температуру на св ій смак або вибер іть один і з попередньо встановлених рецепт і в . Нарешт і , натисн іть кнопку « Пуск / Призупинення ».

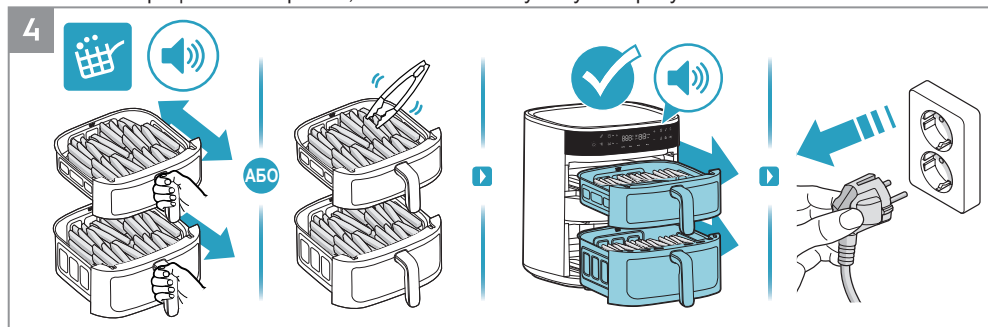

4. Коли п і д час приготування загоріться значок « Нагадування про перем ішування » і пролун ає звуковий сигнал , переверн іть продукти один раз за допомогою термост і йких кухонних прилад і в або обережно злегка струс іть кошик для смаження . Пі сля зак інчення часу приготування пристр і й подасть звуковий сигнал . Пі сля використання в і дключ іть пристр і й в і д мереж і.

Порядок використання — функція синхронізація закінчення приготування

EN
BG
CZ
DE
DK
EE
FI
FR
GR
HR
HU
IT
LT
LV
NO
NL
PL
PT
RO
RU
SE
SI
SK
SR
TR
UA
ES
GE
AL

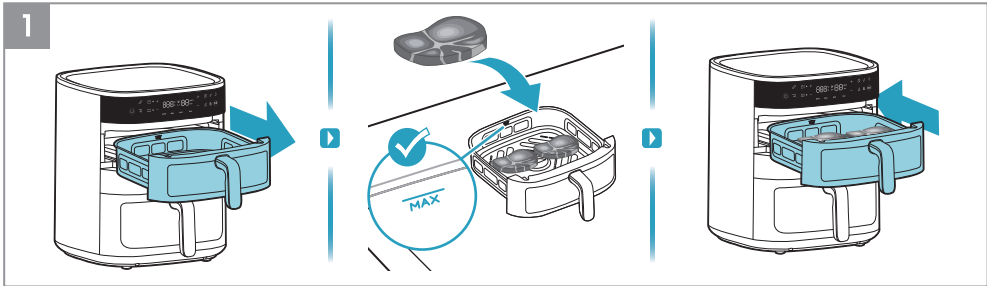

1. Спочатку вийм іть верхн ій кошик і поклад іть у нього продукти , наприклад , стейк .

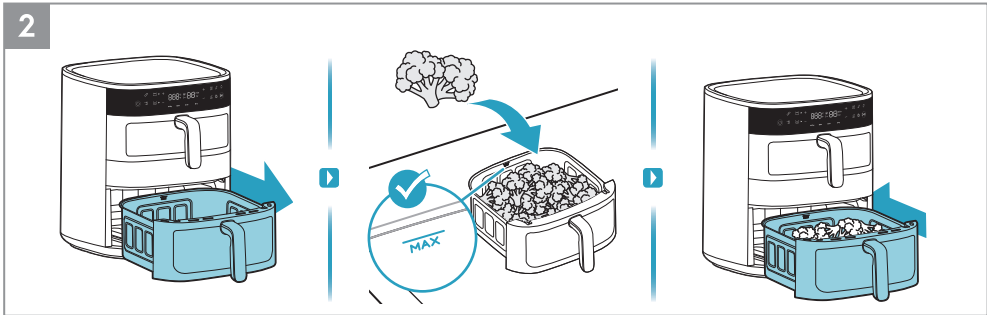

2. Пот і м вийм іть нижн ій кошик і поклад іть у нього продукти , наприклад , брокол і .

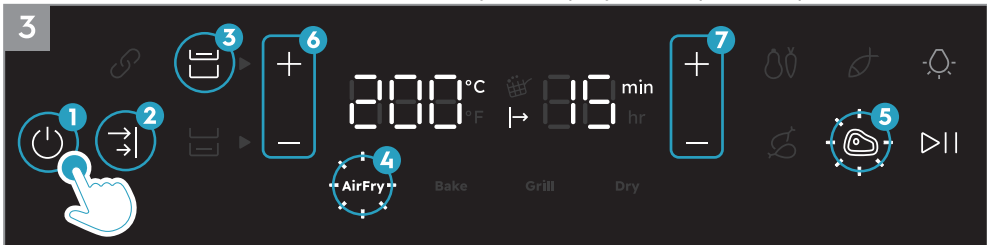

3. Натисн іть кнопку ув і мкнення / вимкнення . Вибер іть функці ю синхрон і зац ії закінчення пр иготування . Спочатку вибер іть верхн ій кошик , пот і м вибер іть бажаний спос і б приготува ння , наприклад , функці ю "Air Fry" (Пов ітряне смаження) . Налаштуйте час і температуру на св ій смак або вибер іть один і з попереднь о встановлених рецепт і в , наприклад , "Стейк" .

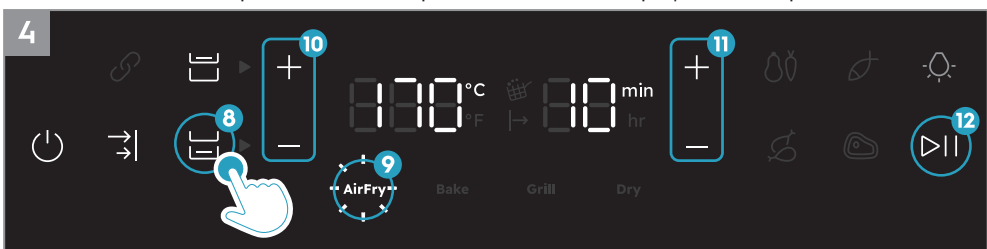

4. Пот і м вибер іть нижн ій кошик , бажаний спос іб приготування , наприклад , функці ю "Air Fry" (П ов ітряне смаження) . Налаштуйте час і температуру на св ій смак або вибер іть один і з попе реднь о встановлених рецепт і в . Нарешт і , натисн іть кнопку "Пуск / Призупинення" .

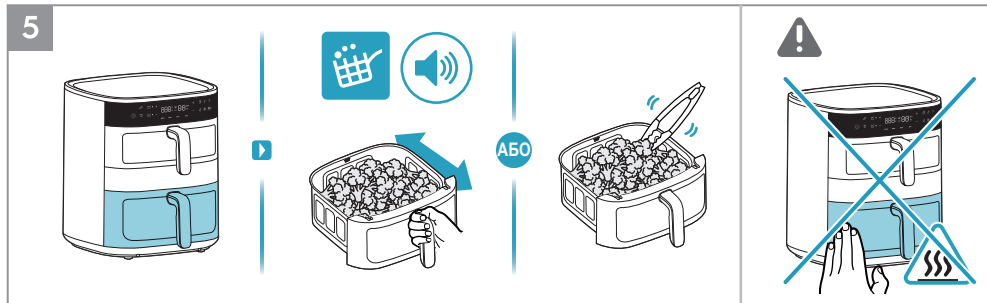

5. При цьому пріоритет в іддає ться нижньому кошику з б іл ьш тривалим часом приготування . Коли п і д час приготування загориться значок "Нагадування про перем і шування" і пролуна є звуковий сигнал , переверні т ь продукти один раз за допомогою термост і йких кухонних прилад і в або обережно злегка струс і т ь кошик для смаження .

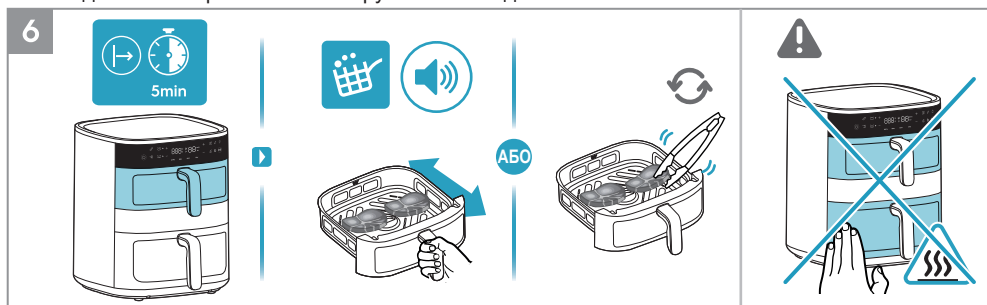

6. Пот і м почеться приготування у верхньому кошику з коротшим часом приготування . Коли п і д час приготування загориться значок "Нагадування про перем і шування" і пролуна є звуковий сигнал , переверні т ь продукти один раз за допомогою термост і йких кухонних прилад і в або обережно злегка струс і т ь кошик для смаження .

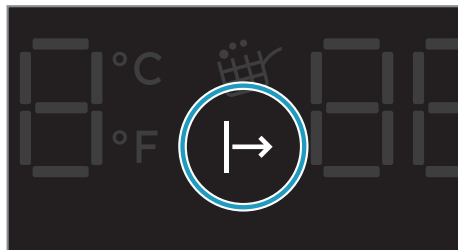

І ндикатор оч і кування приготування

Коли активована "Функц і я синхрон і зац ії за к і н чення приготування", кошик з коротшим часом приготування буде чекати , поки кошик з довшим ч асом приготування не пропрацю є деякий час , щ об обидва кошики могли за к і н чити приготування одночасно . Протягом цього часу "і ндикатор оч і кування приготування" буде св і титися до початк у процесу приготування .

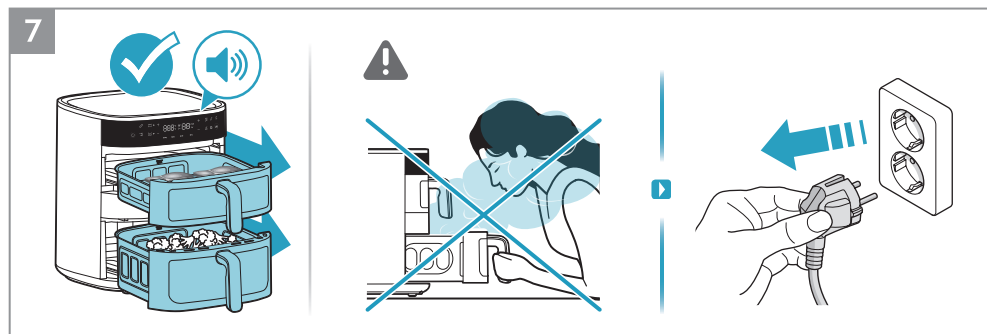

7. П і сля за к і н чення часу приготування пристр і й подасть звуковий сигнал . П і сля використан ня в і дключ і т ь пристр і й в і д мережі .

Очищення

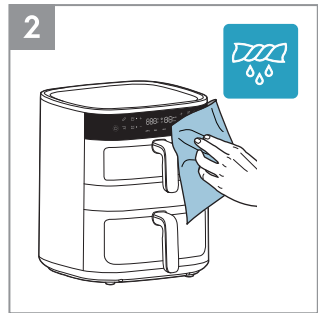
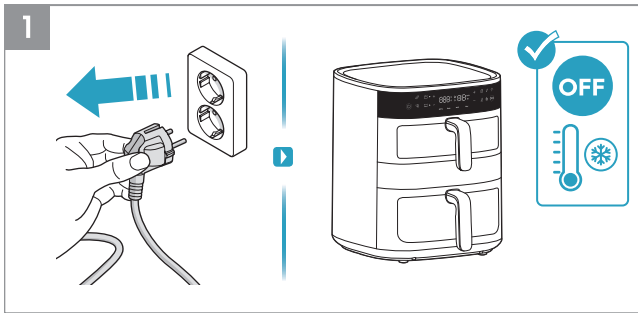

1. Перед очищенням завжди в і дключайте пристрій в і д мережі і і чекайте , поки в і н охолоне .
2. Протр іть зовн і шню поверхню пристрою м 'якою тканиною .

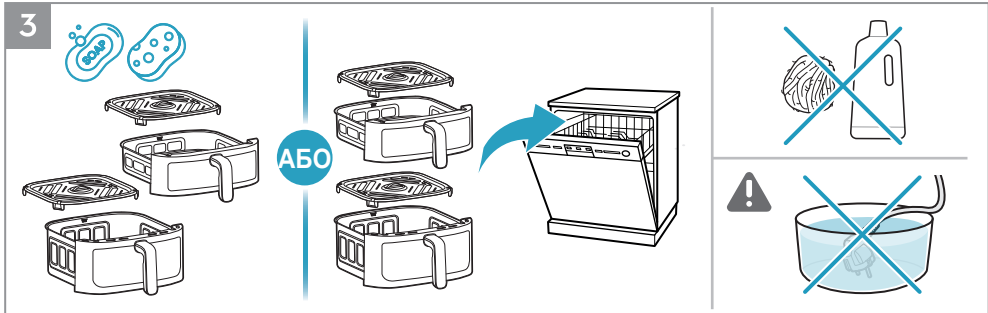

3. Вимийте кошик і реш ітку теплою водою з миючим засобом для посуду або пом і ст іть їх у посудомийну машину .

▲ПРИМ ІТКА : Щоб уникнути пошкодження антипригарного покриття , не використовуйте абразивні чистячі засоби або металеві і інструменти .

ОБЕРЕЖНО : Н іколи не занурюйте пристрій , його шнур або вилку у воду або будь - яку і ншу р і дину .

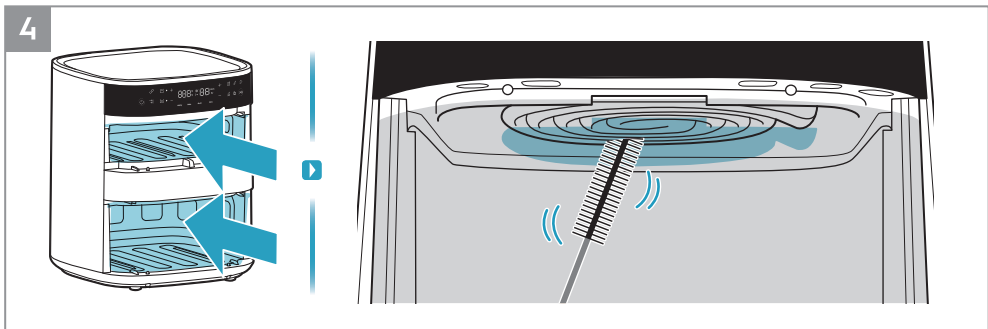











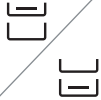





















































4. Очист іть нагр івальний елемент за допомогою чистячо ї щ ітки .

ПРИМ ІТКА : Перед очищенням нагр івального елемента переконайтеся , що пристрій і й повн і ст ю охолонув .

EN
BG
CZ
DE
DK
EE
FI
FR
GR
HR
HU
IT
LT
LV
NO
NL
PL
PT
RO
RU
SE
SI
SK
SR
TR
UA
ES
GE
AL

Кер і вництво з приготування

							
AirFry	7mm/10mm 	 4 л	400 г	180°C	18 хв.		
		 7 л	400 г	180°C	18 хв.		
AirFry		 4 л	400 г	170°C	8 хв.		
		 7 л	400 г	170°C	10 хв.		
AirFry		 4 л	400 г / 2 шт.	140°C	15 хв.		
		 7 л	400 г / 2 шт.	140°C	15 хв.		
AirFry		 4 л	1000 г / 8 шт.	180°C	28 хв.		
		 7 л	1000 г / 8 шт.	180°C	28 хв.		
AirFry		 4 л	400 г / 2 шт.	200°C	10 хв.		
		 7 л	400 г / 2 шт.	200°C	10 хв.		
AirFry		 4 л	220 г / дюйм і в	160°C	12 хв.		
		 7 л	220 г / дюйм і в	160°C	14 хв.		

							
AirFry		 7 л	1200 г	180°C	55 хв .		
AirFry		 7 л	400 г /9 шт .	160°C	20 хв .		
Grill		 4 л	180 г /4 шт .	180°C	8 хв .		
Grill		 7 л	180 г /4 шт .	180°C	9 хв .		
Dry		 4 л	180 г	80°C	3 год .		
Dry		 7 л	180 г	80°C	3 год .		
Dry		 4 л	200 г	80°C	3 год .		
Dry		 7 л	200 г	80°C	3 год .		

- EN
- BG
- CZ
- DE
- DK
- EE
- FI
- FR
- GR
- HR
- HU
- IT
- LT
- LV
- NO
- NL
- PL
- PT
- RO
- RU
- SE
- SI
- SK
- SR
- TR
- UA**
- ES
- GE
- AL

Що робити , коли ...

Проблема	Перевірте , що ...
Ви не можете увімкнути або вимкнути пристрій .	<ul style="list-style-type: none"> • Пристрій правильно підключений до джерела електроживлення . • Кошики знаходяться в правильному положенні . Переконайтеся , що вони повністю вставлені в пристрій , щоб забезпечити подачу електроживлення . • Час приготування встановлено .
Ви не можете вставити кошик у пристрій .	<ul style="list-style-type: none"> • Кошик заповнений понад максимальну місткість . • Кошик встановлений неправильно . Він повинен зафіксуватися , коли ви вставляєте його в пристрій . • Під кошиком знаходиться предмет , який заважає закрити його належним чином .
З пристрою виходить білий дим .	<ul style="list-style-type: none"> • Їжа , яку ви готуєте , занадто жирна . • Кошик , решітка та нагрівальний елемент чисті .
На дисплеї в і зображається E1	• Обрив ланцюга верхнього кошика .
На дисплеї в і зображається E2	• Коротке замикання ланцюга верхнього кошика .
На дисплеї в і зображається E3	• Обрив ланцюга нижнього кошика .
На дисплеї в і зображається E4	• Коротке замикання ланцюга нижнього кошика .
На дисплеї в і зображається E5	• Помилка зв'язку плати управління .
На дисплеї в і зображається E6	• Помилка зв'язку плати живлення .

* Якщо на дисплеї в і зображаються коди помилок , пристрій необхідно в ідремонтувати в сервісному центрі .

Технічні дані

Виріб	Аерофритюрниця
Модель	EAFD11B
Напруга (В змін . струму)	220–240 В
Потужність (Вт)	2700 Вт
Частота (Гц)	50 ~ 60 Hz
Місткість	4 л + 7 л



Libro de instrucciones

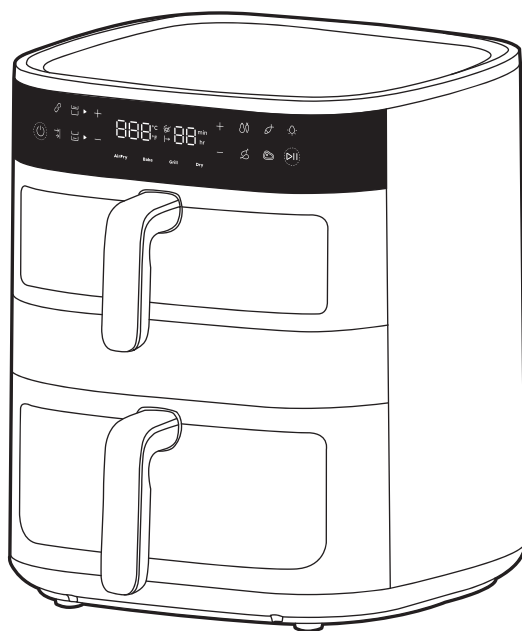

800 Freidora de aire Dual

Vista general

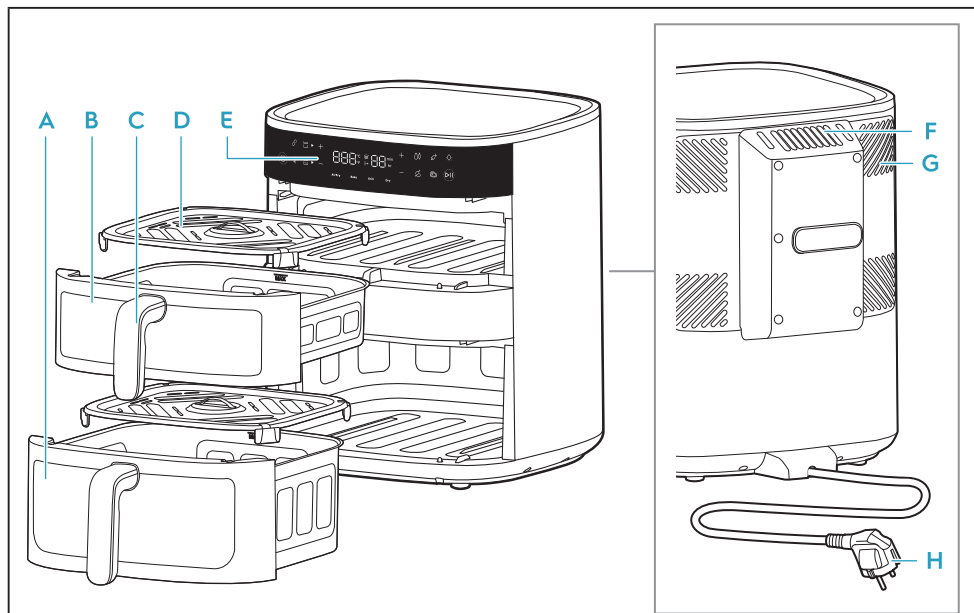

- A Cesta inferior (7 litros) C Asa de la cesta E Panel de control G Sistema de refrigeración
- B Cesta superior (4 litros) D Rejilla F Salida de aire H Cable de alimentación

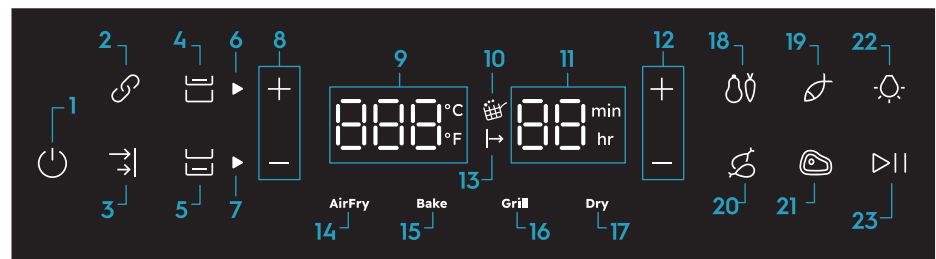

- | | | | |
|---|--|--|----------------------------|
| 1. Encendido/Apagado | 7. Indicador de la cesta inferior | 11. Indicador de tiempo (Freidora de aire: 1-99 min, Deshidratar: 1-5 h) | 16. Función de grill |
| 2. Función de enlace | 8. Control de temperatura | 12. Control de tiempo | 17. Función de deshidratar |
| 3. Función de finalización sincronizada | 9. Indicador de temperatura (40-200°C) | 13. Espera para la cocción | 18. Verduras |
| 4. Control de la cesta superior | 10. Recordatorio de remover | 14. Función de freidora de aire | 19. Pescado |
| 5. Control de la cesta inferior | | 15. Función de hornear | 20. Pollo |
| 6. Indicador de la cesta superior | | | 21. Filete |
| | | | 22. Control de luz |
| | | | 23. Iniciar/Pausar |

Antes del primer uso

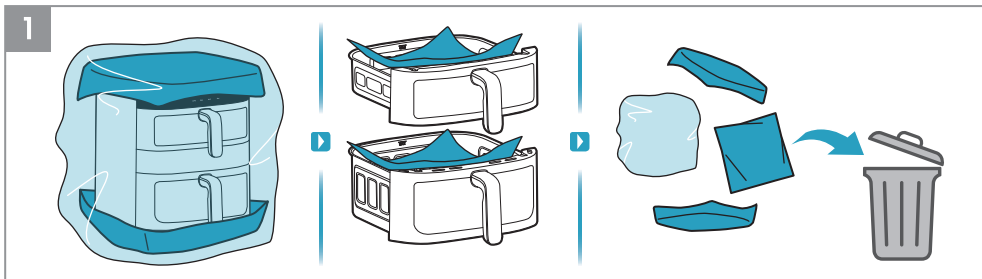

1. Retire todo el embalaje y el material protector.

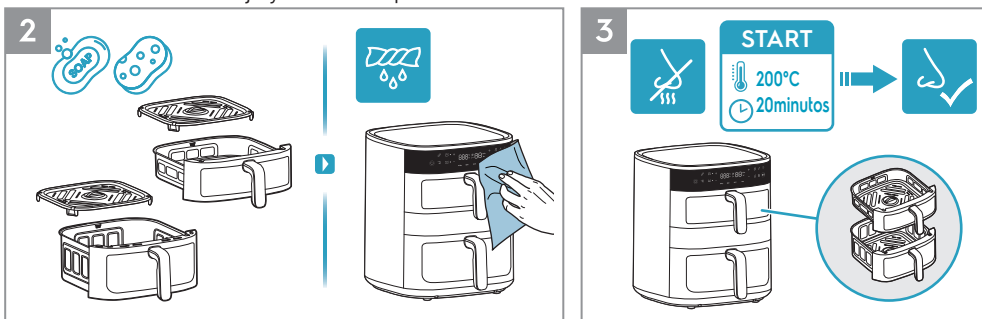



2. Limpie la bandeja y la rejilla con agua tibia y detergente para platos. Limpie el interior y el exterior del aparato con un paño suave.

3. Es normal que un aparato nuevo emita olores las primeras veces que se utiliza. Asegúrese de que la freidora de aire esté vacía y déjela funcionar a 200 °C durante 20 minutos antes del primer uso para evitar esto.

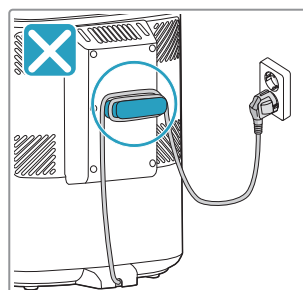
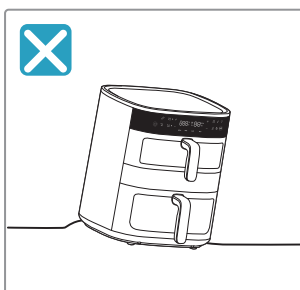
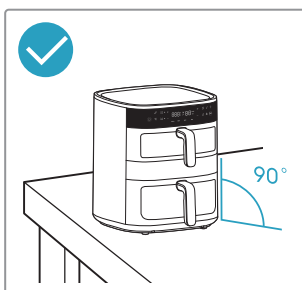
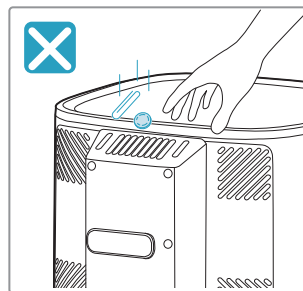
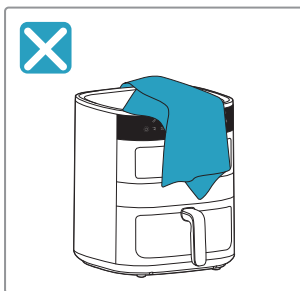
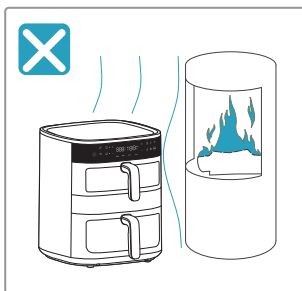



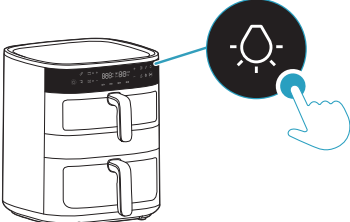
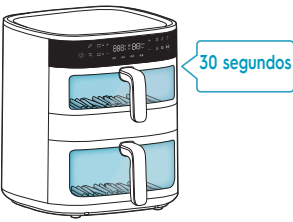

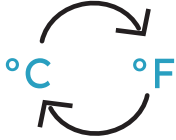



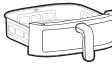

! Precauciones de seguridad









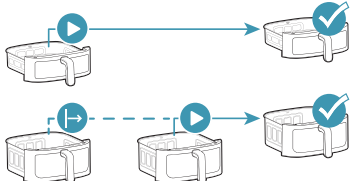







Control de luz y conversión de la escala de temperatura

 <p>Control de luz</p>		 <p>30 segundos</p>
<p>°C/°F</p> <p>Conversión de la escala de temperatura</p>	 <p>30 segundos</p>	

Selección de la cesta

	 <p>4 litros</p>	 <p>7 litros</p>	
 <p>Cesta superior</p>			
 <p>Cesta inferior</p>			
 <p>Función de enlace</p>			
 <p>Función de finalización sincronizada</p>			

Funciones predefinidas

					
AirFry	180°C	15 minutos	60-200°C	1-99 minutos	
	170°C	10 minutos	60-200°C	1-99 minutos	
	140°C	15 minutos	60-200°C	1-99 minutos	
	180°C	30 minutos	60-200°C	1-99 minutos	
	200°C	10 minutos	60-200°C	1-99 minutos	
Bake	170°C	15 minutos	60-200°C	1-99 minutos	
Grill	200°C	5 minutos	60-200°C	1-99 minutos	
Dry	80°C	5 horas	40-80°C	1-5 horas	

Antes de cocinar

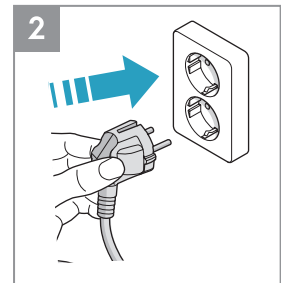
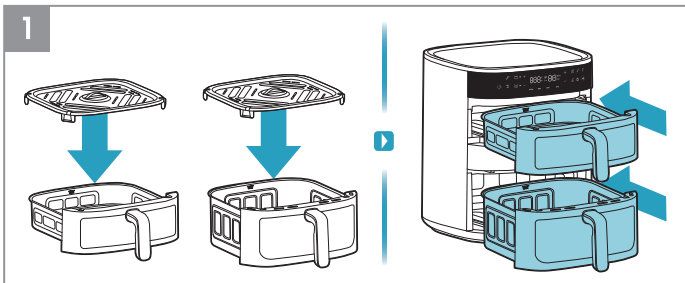

1. Antes de cada cocción, coloque la rejilla dentro de la cesta (no es necesario retirar los soportes de silicona resistentes al calor de la rejilla) e introduzca completamente la cesta en el aparato.
2. Conecte el enchufe a la toma de corriente.

Cómo usar - Cesta única

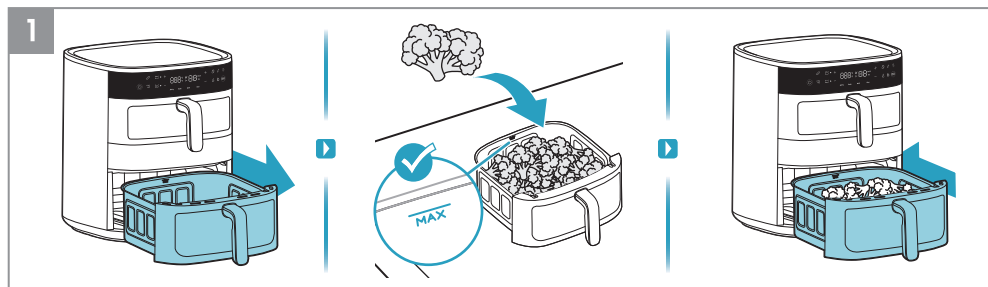

1. Saque una cesta y colóquela sobre una superficie estable; ponga los alimentos en la cesta respetando la indicación de capacidad "MAX.". A continuación, introduzca completamente la cesta con los alimentos en el aparato.

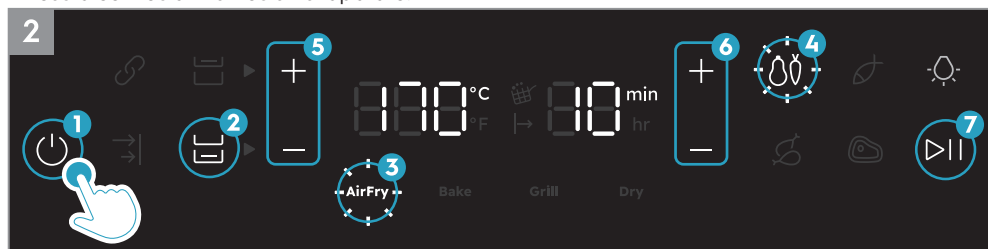

2. Pulse el botón Encendido/Apagado. Primero seleccione la cesta con los alimentos. A continuación, seleccione el método de cocción que quiera, por ejemplo la función freidora de aire. Ajuste el tiempo y la temperatura a su gusto o seleccione una de las recetas predefinidas, por ejemplo, Verduras. Por último, pulse el botón Iniciar/Pausar.

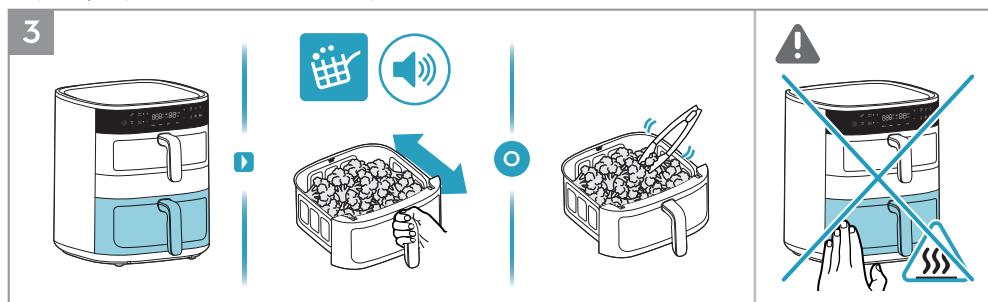

3. Cuando el icono "Recordatorio de remover" se ilumine y emita un pitido durante el proceso de cocción, utilice utensilios resistentes al calor para dar la vuelta a los alimentos una vez o remueva suavemente los alimentos en la cesta de freír.

⚠ **PRECAUCIÓN:** No agite o remueva la cesta de freír con fuerza para evitar que los alimentos salpiquen y puedan causar quemaduras.

⚠ **PRECAUCIÓN:** Tenga cuidado con las superficies calientes cuando el aparato esté en funcionamiento.

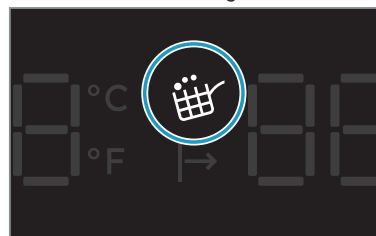

Recordatorio de remover

El "Recordatorio de remover" se activa durante la función freidora de aire y en las recetas predefinidas, como Verduras, Pescado, Muslos de pollo y Filete.

Cuando llegue el momento de remover o dar la vuelta a los alimentos, el icono "Recordatorio de remover" se iluminará y parpadeará durante un minuto, mientras que la señal acústica sonará tres veces.

El "Recordatorio de remover" no es obligatorio; la cocción continuará con normalidad aunque no se remuevan o se de la vuelta a los alimentos.



4. Al finalizar el tiempo de cocción, el aparato emitirá una señal acústica. Retire la cesta con cuidado y colóquela sobre una superficie resistente al calor. Desenchufe el aparato después de utilizarlo.

⚠ **PRECAUCIÓN:** Puede salir vapor caliente de la cesta cuando se abre durante la cocción o al finalizarla. Mantenga la cara, los brazos y las manos alejados del vapor al abrirla.

Cómo usar - Cesta superior + cesta inferior

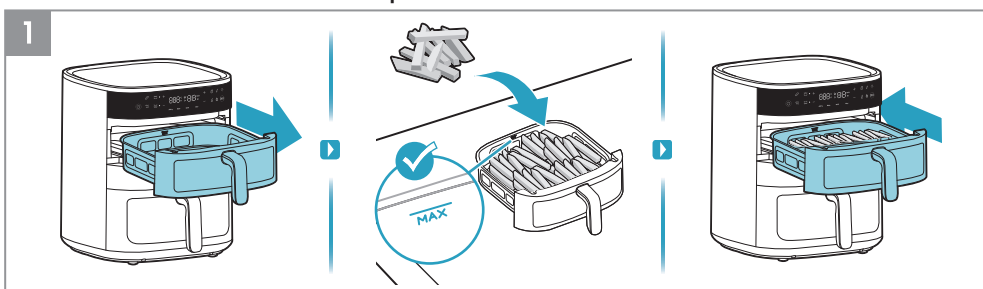

1. Primero, saque la cesta superior y coloque los alimentos en la cesta, por ejemplo patatas fritas.

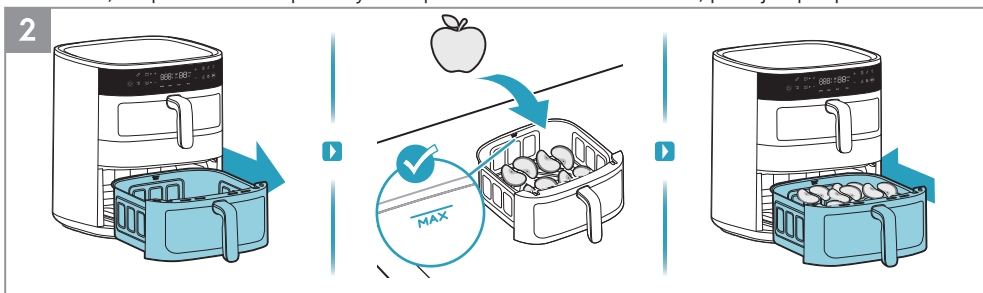

2. En segundo lugar, saque la cesta inferior y coloque los alimentos en la cesta, por ejemplo rodajas de manzana.



3. Pulse el botón Encendido/Apagado. Primero seleccione la cesta superior. A continuación, seleccione el método de cocción que quiera, por ejemplo la función freidora de aire. Ajuste el tiempo y la temperatura a su gusto o seleccione una de las recetas predefinidas, por ejemplo, Verduras. Por último, pulse el botón Iniciar/Pausar.



4. A continuación seleccione la cesta inferior. Después seleccione el método de cocción deseado, por ejemplo la función de deshidratar. Ajuste el tiempo y la temperatura a su gusto. Por último, pulse el botón Iniciar/Pausar.

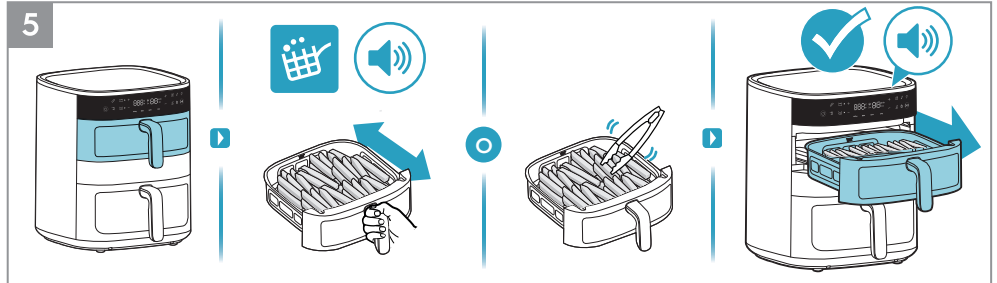

5. Cuando el icono "Recordatorio de remover" se ilumine y emita un pitido durante el proceso de cocción, utilice utensilios resistentes al calor para dar la vuelta a los alimentos una vez o remueva suavemente los alimentos en la cesta de freír. Al finalizar el tiempo de cocción de la cesta superior, el aparato emitirá una señal acústica.

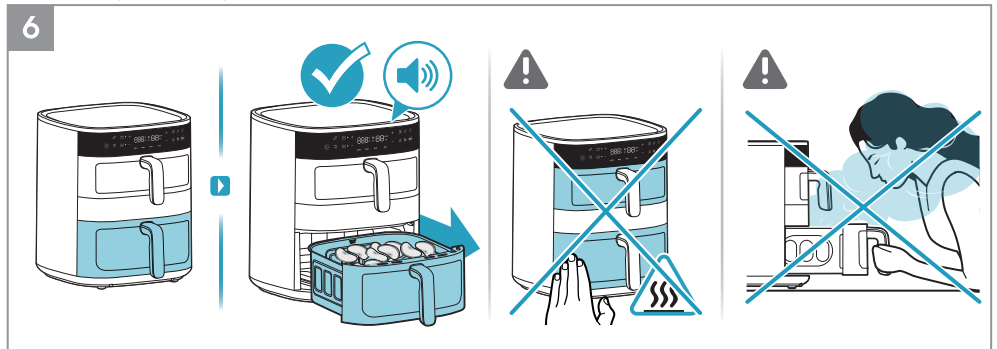

6. Al finalizar el tiempo de cocción de la cesta inferior, el aparato emitirá una señal acústica.

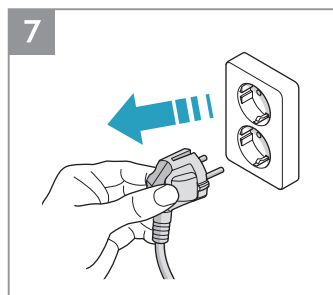

7. Desenchufe el aparato después de utilizarlo.

Cómo usar – Función de enlace

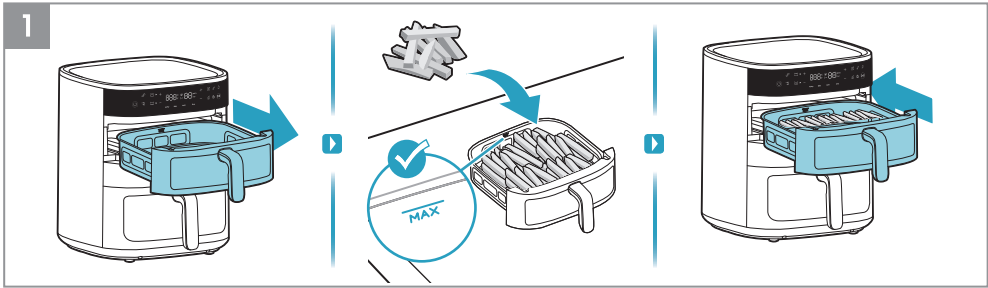

1. Primero, saque la cesta superior y coloque los alimentos en la cesta, por ejemplo patatas fritas.

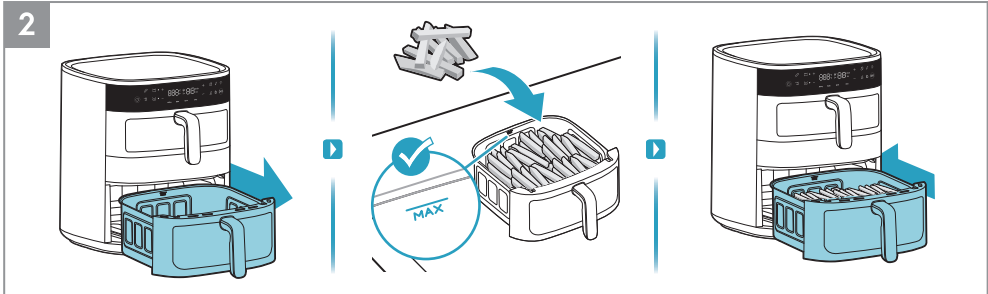

2. En segundo lugar, saque la cesta inferior y coloque los alimentos en la cesta, por ejemplo patatas fritas.



3. Pulse el botón Encendido/Apagado. Primero seleccione la función de enlace. A continuación, seleccione el método de cocción que quiera, por ejemplo la función freidora de aire. Ajuste el tiempo y la temperatura a su gusto o seleccione una de las recetas predefinidas. Por último, pulse el botón Iniciar/Pausar.

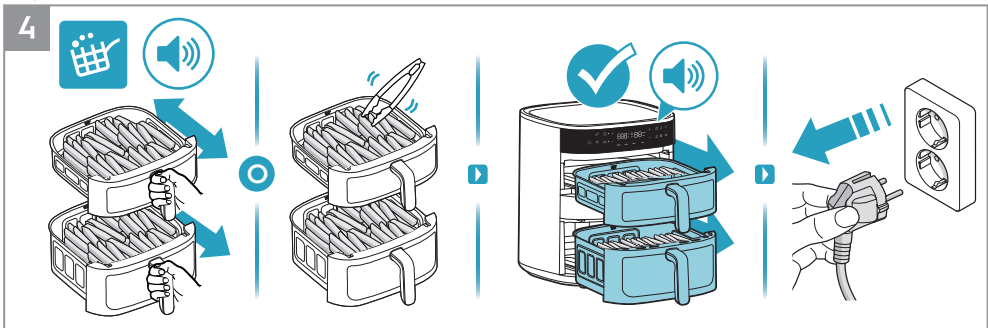

4. Cuando el icono «Recordatorio de remover» se ilumine y emita un pitido durante el proceso de cocción, utilice utensilios resistentes al calor para dar la vuelta a los alimentos una vez o remueva suavemente los alimentos en la cesta de freír. Al finalizar el tiempo de cocción, el aparato emitirá una señal acústica. Desenchufe el aparato después de utilizarlo.

EN **Cómo usar** – Función de finalización sincronizada

BG
CZ
DE
DK
EE
FI
FR
GR
HR
HU
IT
LT
LV
NO
NL
PL
PT
RO
RU
SE
SI
SK
SR
TR
UA
ES
GE
AL

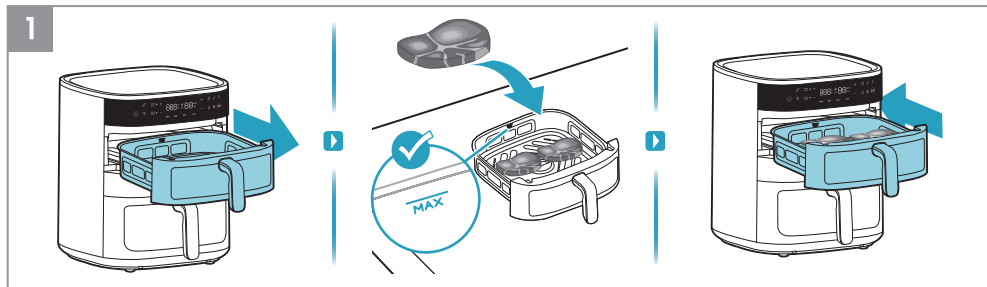

1. Primero, saque la cesta superior y coloque los alimentos en la cesta, por ejemplo un filete.

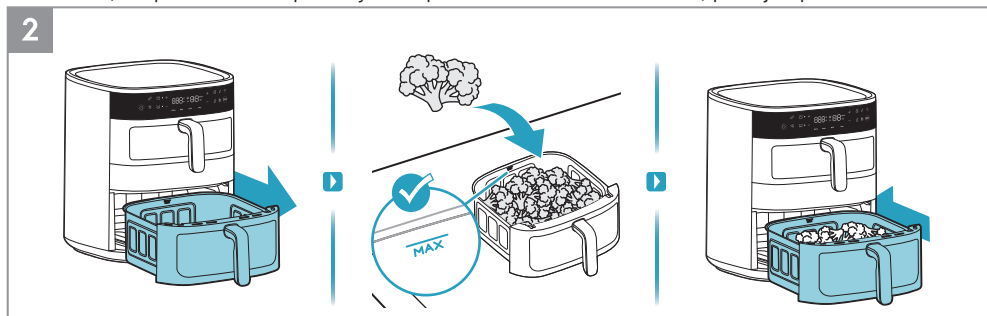

2. En segundo lugar, saque la cesta inferior y coloque los alimentos en la cesta, por ejemplo brócoli.



3. Pulse el botón Encendido/Apagado. Seleccione la función de finalización sincronizada. Primero seleccione la cesta superior y después el método de cocción deseado, por ejemplo, la función freidora de aire. Ajuste el tiempo y la temperatura a su gusto o seleccione una de las recetas predefinidas, por ejemplo Filete.



4. A continuación seleccione la cesta inferior y el método de cocción deseado, por ejemplo la función freidora de aire. Ajuste el tiempo y la temperatura a su gusto o seleccione una de las recetas predefinidas. Por último, pulse el botón Iniciar/Pausar.

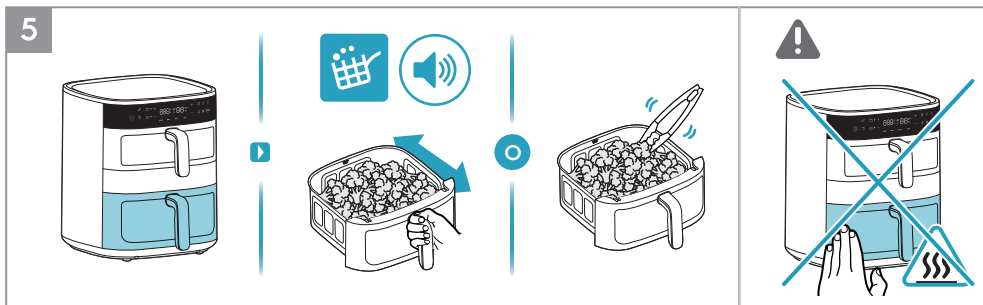

5. Primero, la cesta inferior con el tiempo de cocción más largo se iniciará antes. Cuando el icono "Recordatorio de remover" se ilumine y emita un pitido durante el proceso de cocción, utilice utensilios resistentes al calor para dar la vuelta a los alimentos una vez o remueva suavemente los alimentos en la cesta de freír.

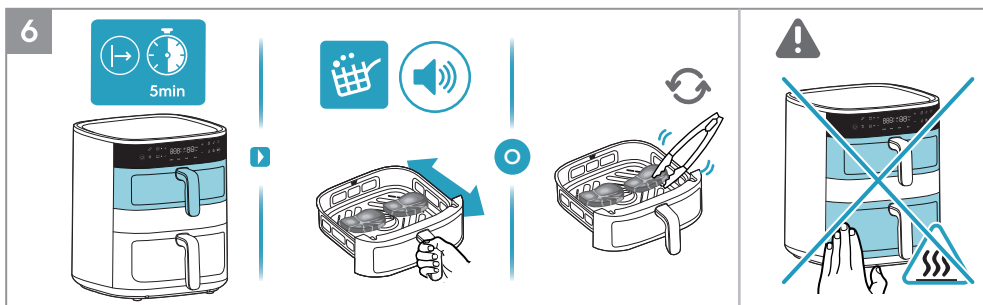

6. Después, la cesta superior con el tiempo de cocción más corto comenzará la cocción. Cuando el icono "Recordatorio de remover" se ilumine y emita un pitido durante el proceso de cocción, utilice utensilios resistentes al calor para dar la vuelta a los alimentos una vez o remueva suavemente los alimentos en la cesta de freír.

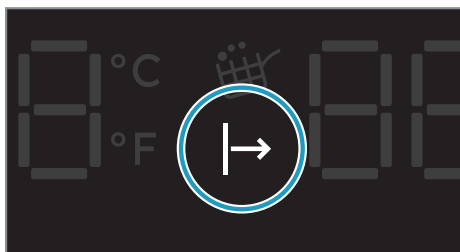

Indicador de espera para la cocción

Cuando la "función de finalización sincronizada" está activada, la cesta con el tiempo de cocción más corto esperará antes de comenzar hasta que la cesta con el tiempo de cocción más largo lleve un tiempo cocinando, de modo que ambas cestas finalicen la cocción al mismo tiempo. Durante este periodo, el "indicador de espera para la cocción" permanecerá encendido hasta que comience la cocción.

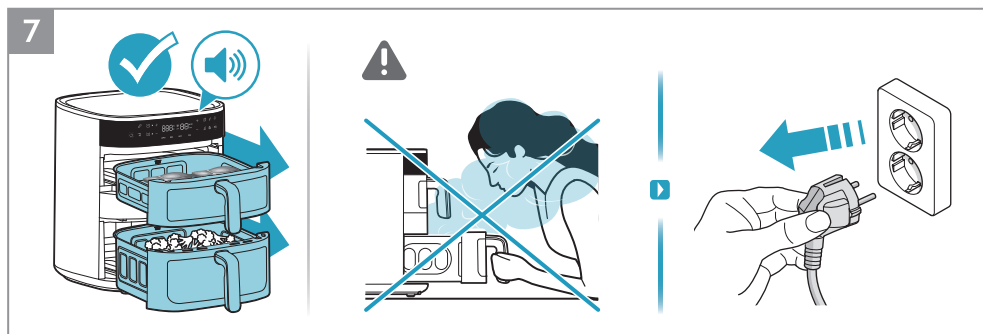

7. Al finalizar el tiempo de cocción, el aparato emitirá una señal acústica. Desenchufe el aparato después de utilizarlo.

Limpeza

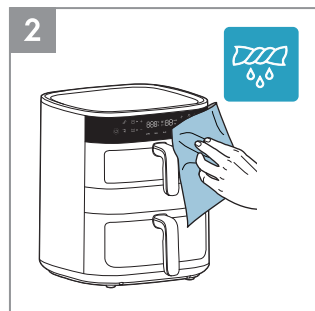
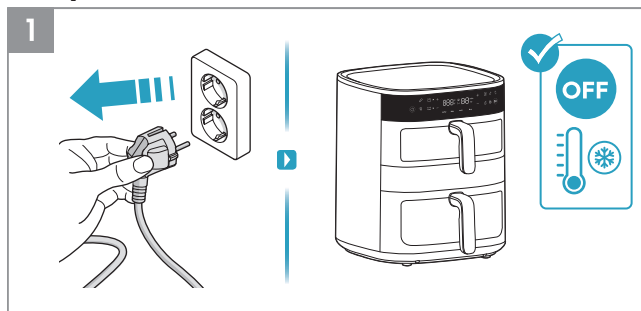

1. Desenchufe siempre el aparato y espere a que se enfríe antes de limpiarlo.
2. Limpie el exterior del aparato con un paño suave.

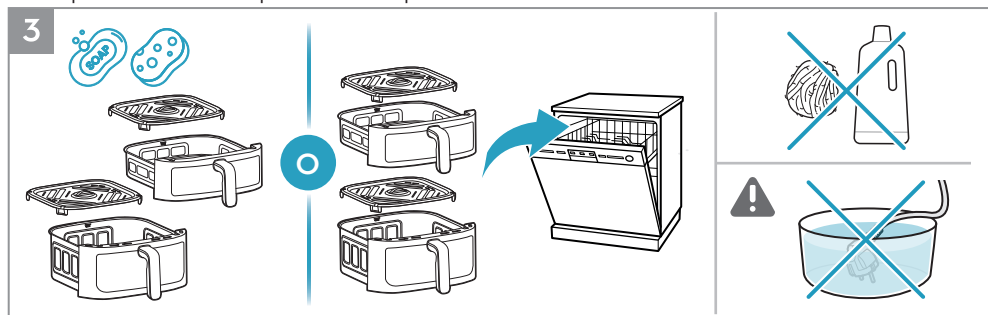

3. Limpie la bandeja y la rejilla con agua tibia y detergente para platos, o colóquelas en el lavavajillas.

▲NOTA: Evite utilizar productos de limpieza abrasivos o utensilios metálicos para proteger el revestimiento antiadherente.



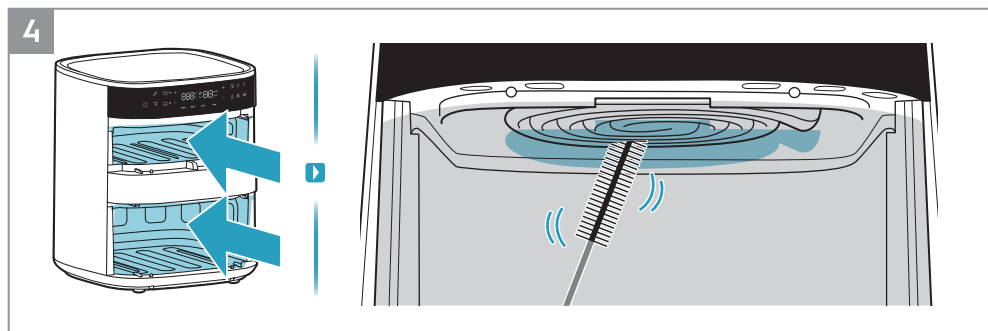









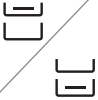

























PRECAUCIÓN: Nunca sumerja el producto, el cable o el enchufe en agua ni en ningún otro líquido.



4. Limpie el elemento calefactor con un cepillo de limpieza.













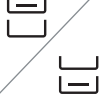











NOTA: Asegúrese de que el aparato esté completamente frío antes de limpiar el elemento calefactor.

Guía de cocción

							
AirFry	7mm/10mm 	 4 litros	400g	180°C	18minutos		
		 7 litros	400g	180°C	18minutos		
AirFry		 4 litros	400g	170°C	8minutos		
		 7 litros	400g	170°C	10minutos		
AirFry		 4 litros	400g/2unidades	140°C	15minutos		
		 7 litros	400g/2unidades	140°C	15minutos		
AirFry		 4 litros	1000g/8unidades	180°C	28minutos		
		 7 litros	1000g/8unidades	180°C	28minutos		
AirFry		 4 litros	400g/2unidades	200°C	10minutos		
		 7 litros	400g/2unidades	200°C	10minutos		
AirFry		 4 litros	220g/6pulgadas	160°C	12minutos		
		 7 litros	220g/6pulgadas	160°C	14minutos		

EN
BG
CZ
DE
DK
EE
FI
FR
GR
HR
HU
IT
LT
LV
NO
NL
PL
PT
RO
RU
SE
SI
SK
SR
TR
UA
ES
GE
AL

EN
BG
CZ
DE
DK
EE
FI
FR
GR
HR
HU
IT
LT
LV
NO
NL
PL
PT
RO
RU
SE
SI
SK
SR
TR
UA
ES
GE
AL

							
AirFry		 7litros	1200g	180°C	55minutos		
AirFry		 7litros	400g/9unidades	160°C	20minutos		
Grill		 4litros	180g/4unidades	180°C	8minutos		
		 7litros	180g/4unidades	180°C	9minutos		
Dry		 4litros	180g	80°C	3h		
		 7litros	180g	80°C	3h		
Dry		 4litros	200g	80°C	3h		
		 7litros	200g	80°C	3h		

Qué hacer si...

Problema	Compruebe si...
No puede activar ni utilizar el aparato.	<ul style="list-style-type: none"> • El aparato está correctamente conectado al suministro eléctrico. • Las cestas están en la posición correcta. Compruebe que estén completamente introducidas en el aparato para permitir el suministro eléctrico. • El tiempo de cocción está configurado.
No puede introducir la cesta en el aparato.	<ul style="list-style-type: none"> • La cesta está llena por encima de su capacidad máxima. • La cesta está colocada correctamente. Debe hacer clic al colocarla en el aparato. • Hay un objeto debajo de la cesta que impide cerrarla correctamente.
Sale humo blanco del aparato.	<ul style="list-style-type: none"> • Los alimentos que está preparando son demasiado grasos. • La cesta, la rejilla y el elemento calefactor están limpios.
La pantalla muestra E1.	• Circuito abierto de la cesta superior.
La pantalla muestra E2.	• Circuito corto de la cesta superior.
La pantalla muestra E3.	• Circuito abierto de la cesta inferior.
La pantalla muestra E4.	• Circuito corto de la cesta inferior.
La pantalla muestra E5.	• Error de comunicación del PCBA de control.
La pantalla muestra E6.	• Error de comunicación del PCBA de alimentación.

* En caso de que la pantalla muestre códigos de error, el aparato debe ser reparado por el Servicio Técnico.

Datos técnicos

Producto	Freidora de aire
Modelo	EAFD11B
Voltaje (V~)	220 V - 240 V
Potencia (W)	2700 W
Frecuencia (Hz)	50 ~ 60 Hz
Capacidad	4 L + 7 L



ინსტრუქციის სახელმძღვანელო

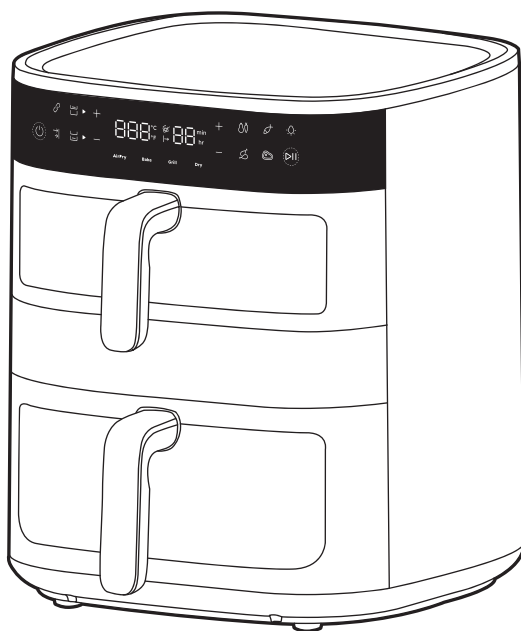

800 ორგანოფილებიანი აეროგრილი

ზოგადი მიმოხილვა

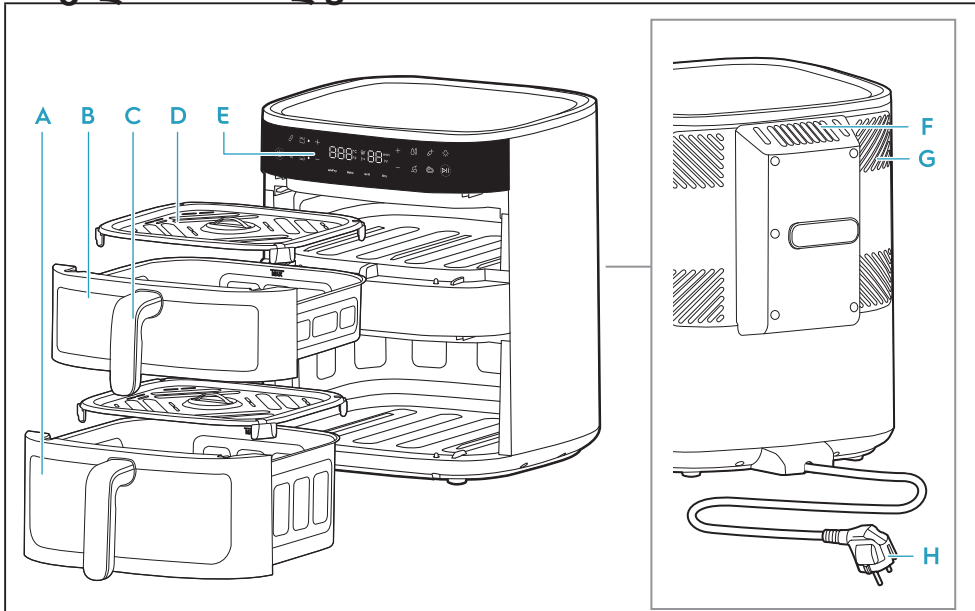

- | | | | |
|----------------------------|--------------------------|------------------------------|-----------------------------|
| A ქვედა კალათი (7ლ) | C კალათის სახლური | E მართვის პანელი | G გაგრილების სისტემა |
| B ზედა კალათი (4ლ) | D გრილი | F ჰაერის გამოსასვლელი | H მთავარი კაბელი |

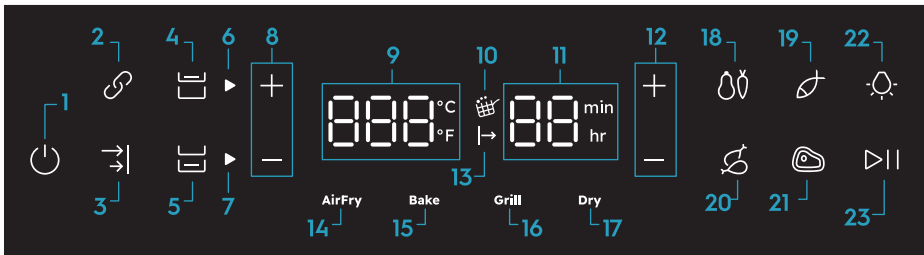

- | | | | |
|--------------------------------------|--|---------------------------------|----------------------|
| 1. ჩართვა/გამორთვა | 8. ტემპერატურის მართვა | 12. დროის მართვა | 19. თევზი |
| 2. მიზმის ფუნქცია | 9. ტემპერატურის ინდიკატორი (40-200°C) | 13. მომზადების რეჟიმის მოლოდინი | 20. ქათამი |
| 3. დასრულების ფუნქციის სინქრონიზაცია | 10. შერევის შესახებ შეხსენება | 14. აეროგრის ფუნქცია | 21. სტიკი |
| 4. ზედა კალათის მართვა | 11. დროის ინდიკატორი (აეროგრის: 1-99 წთ, დეჰიდრატაცია: 1-5 სთ) | 15. ცხობის ფუნქცია | 22. განათების მართვა |
| 5. ქვედა კალათის მართვა | | 16. გრილის ფუნქცია | 23. დაკვრა/დაპაუზება |
| 6. ზედა კალათის ინდიკატორი | | 17. შრობის ფუნქცია | |
| 7. ქვედა კალათის ინდიკატორი | | 18. ბოსტნეული | |

პირველ გამოყენებამდე

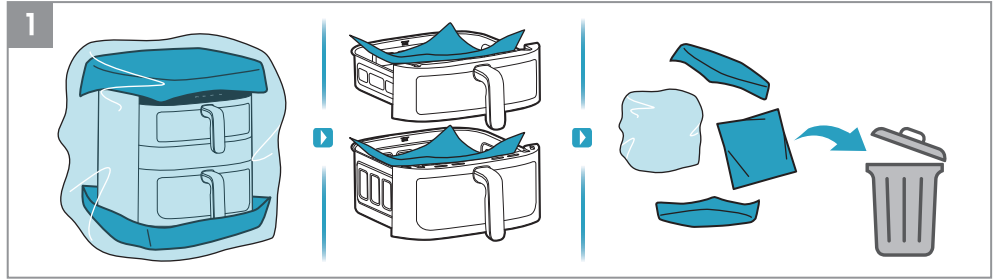

1. მოხსენით მთლიანი შეფუთვა და დამცავი მასალა.

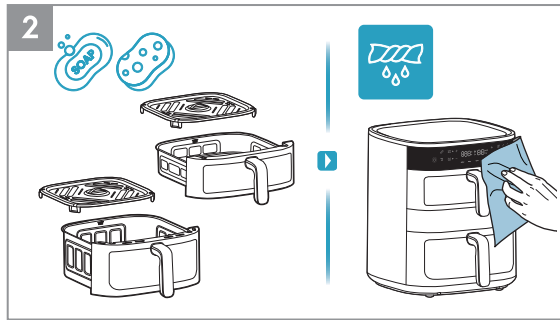

2. თბილი წყლითა და ჭურჭლის სარეცხი სითხით გაასუფთავეთ ტაფა და გრილი. მოწყობილობის შიდა და გარე ზედაპირები განმინდეთ რბილი ნაჭრით.

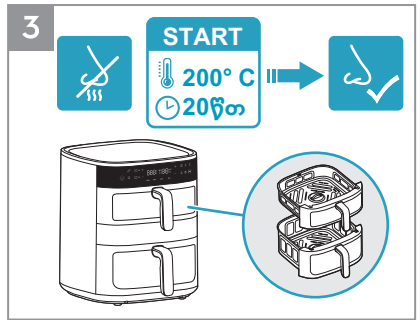



3. ახალი მოწყობილობის პირველ გამოყენებისას სუნის გამოყოფა ნორმალურია. ამ სუნის თავიდან ასაცილებლად, პირველ გამოყენებამდე ცარიელი აეროგრილი ჩართეთ 200°C ტემპერატურაზე 20 წუთით.

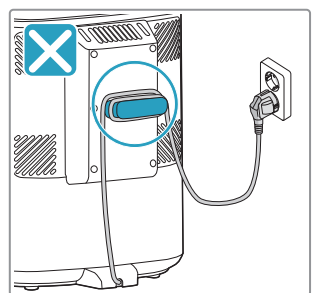
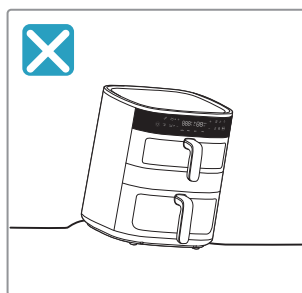
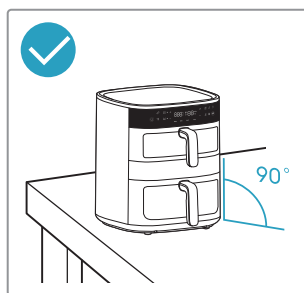
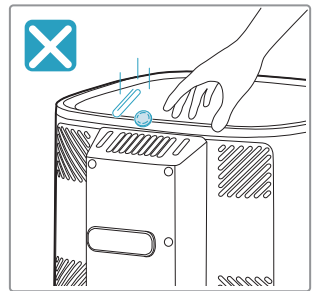
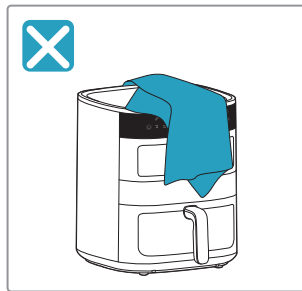
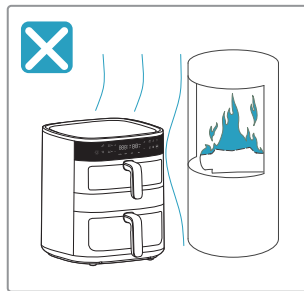





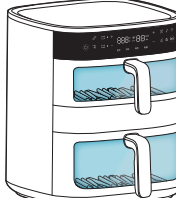
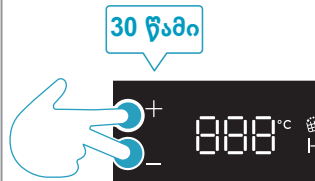
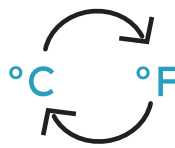



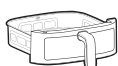

⚠ უსაფრთხოების ზომები



განათების მართვა და ტემპერატურული შკალის კონვერსია





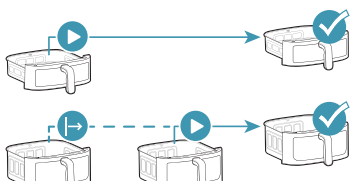





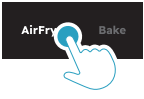



 <p>განათების მართვა</p>		 <p>30 წამი</p>
<p>°C/°F</p> <p>ტემპერატურული შკალის კონვერსია</p>	 <p>30 წამი</p>	

კალათის არჩევა

	 <p>4ლ</p>	 <p>7ლ</p>	
 <p>ზედა კალათი</p>			
 <p>ქვედა კალათი</p>			
 <p>მიბმის ფუნქცია</p>			
 <p>დასრულების ფუნქციის სინქრონიზაცია</p>			

- EN
- BG
- CZ
- DE
- DK
- EE
- FI
- FR
- GR
- HR
- HU
- IT
- LT
- LV
- NO
- NL
- PL
- PT
- RO
- RU
- SE
- SI
- SK
- SR
- TR
- UA
- ES
- GE**
- AL

წინასწარ დაყენებული პროგრამები

					
Air Fry	180°C	15წთ	60~200°C	1~99წთ	
	170°C	10წთ	60~200°C	1~99წთ	
	140°C	15წთ	60~200°C	1~99წთ	
	180°C	30წთ	60~200°C	1~99წთ	
	200°C	10წთ	60~200°C	1~99წთ	
Bake	170°C	15წთ	60~200°C	1~99წთ	
Grill	200°C	5წთ	60~200°C	1~99წთ	
Dry	80°C	5სთ	40~80°C	1~5სთ	

მომზადება მოხმარებამდე

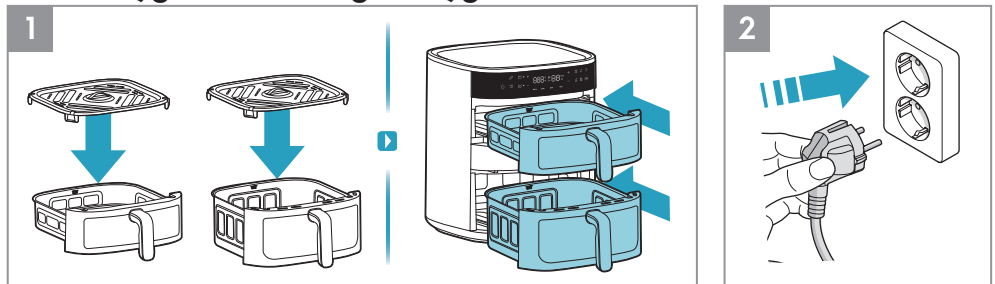

1. თითოეული მომზადების წინ მოათავსეთ გრილი კალათაში (გრილის სითბოგამძლე სილიკონის ბალიშები მოხსნას არ საჭიროებს) და სრულად შენიეთ კალათა მოწყობილობაში.
2. შეაერთეთ კვების შტეფსელი ელექტროროზეტში.

გამოყენების ინსტრუქცია - ერთკალათიანი

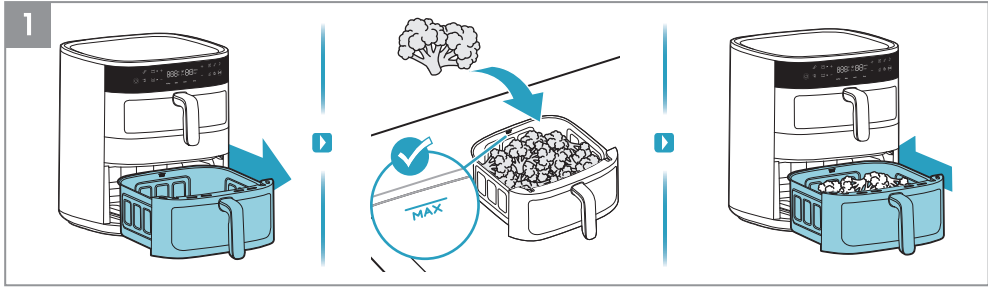

1. გამოიღეთ ერთი კალათა და მოათავსეთ სტაბილურ ზედაპირზე. ჩადეთ საკვები კალათაში, ყურადღებით დაიცავით "MAX." ნიშნული. კალათა საკვებით სრულად შესწიეთ მოწყობილობაში.



2. დააჭირეთ ჩართვა/გამორთვის ლილავს (On/Off). აირჩიეთ ის კალათა, რომელშიც საკვებია. აირჩიეთ სასურველი მომზადების რეჟიმი, მაგალითად, აეროგრილის ფუნქცია. დრო და ტემპერატურა მორაგეთ თქვენს გემოვნებას ან აირჩიეთ წინასწარ დაყენებული რეცეპტებიდან ერთ-ერთი, მაგალითად, ბოსტნეული. ბოლოს დააჭირეთ დაკვრა/დაბაუზების ლილავს.

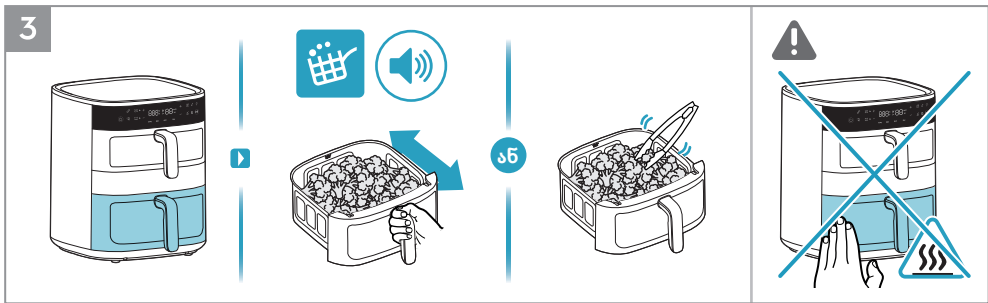

3. როდესაც მომზადების პროცესში „შერხვეის შესახებ შეხსენების“ ხატულა აინთება და ხმოვანი სიგნალი გაისმის, გამოიყენეთ სითბოგამძლე ხელსაწყოები, რათა ერთხელ გადმოაბრუნოთ საკვები ან ფრთხილად შეანჯღრიოთ კალათაში მოთავსებული ინგრედიენტები.

⚠ **სიფრთხილე:** არ შეანჯღრიოთ კალათა ძლიერად, რათა თავიდან აიცილოთ საკვების გაშეფეხვის და დამწვრობის მიღების რისკი.

⚠ **სიფრთხილე:** ფრთხილად მოეპყარით ცხელი ზედაპირებს, როდესაც მოწყობილობა მუშაობს.

შერხვეის შესახებ შეხსენება

„შერხვეის შესახებ შეხსენება“ აქტიურდება აეროგრილის ფუნქციასა და წინასწარ დაყენებულ რეცეპტებში, როგორცაა ბოსტნეული, თევზი, ქათმის ბარკლები და სტიკი.

საკვების გადაბრუნების ან მსუბუქად შერხვეის დრო რომ დადგება, აინთება „შერხვეის შესახებ შეხსენების“ ხატულა და იგი ერთი წუთის განმავლობაში იციმციმებს, ხოლო ხმოვანი სიგნალი სამჯერ განმეორდება.

„შერხვეის შესახებ შეხსენება“ სავალდებულო არ არის - საკვები რომც არ გადააბრუნოთ ან შეანჯღრიოთ, მომზადება ჩვეულებრივ გაგრძელდება.

- EN
- BG
- CZ
- DE
- DK
- EE
- FI
- FR
- GR
- HR
- HU
- IT
- LT
- LV
- NO
- NL
- PL
- PT
- RO
- RU
- SE
- SI
- SK
- SR
- TR
- UA
- ES
- GE
- AL



4. მომზადების დროის ამონურვისას მოწყობილობა გამოსცემს ხმოვან სიგნალს. ფრთხილად ამოიღეთ კალათა და მოათავსეთ სითბოგამძლე ზედაპირზე. გამოყენების დასრულების შემდეგ მოწყობილობა გამორთეთ ქსელიდან.

⚠ **სიფრთხილე:** თუ კალათას მომზადების პროცესის განმავლობაში ან მისი დასრულებისას ხსნით, შეიძლება ცხელი ორთქლი გამოვიდეს. გახსნისას დაიცავით სახე, ხელები და მკლავები ორთქლისგან, რათა თავიდან აიცილოთ დამწვრობა.

ერთდროული გამოყენება - ზედა და ქვედა კალათა

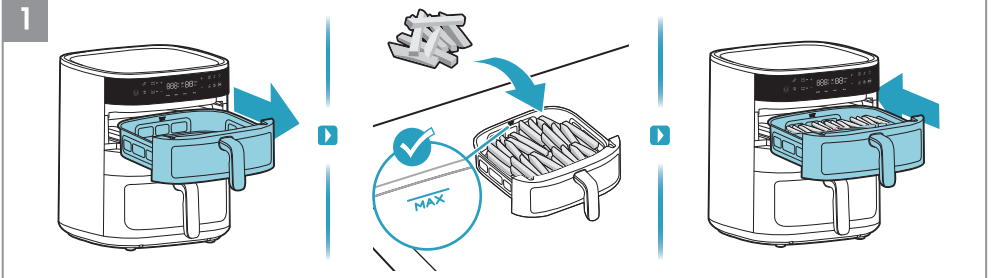

1. გამოიღეთ ზედა კალათა და მოათავსეთ საკვები, მაგალითად, კარტოფილი ფრი.

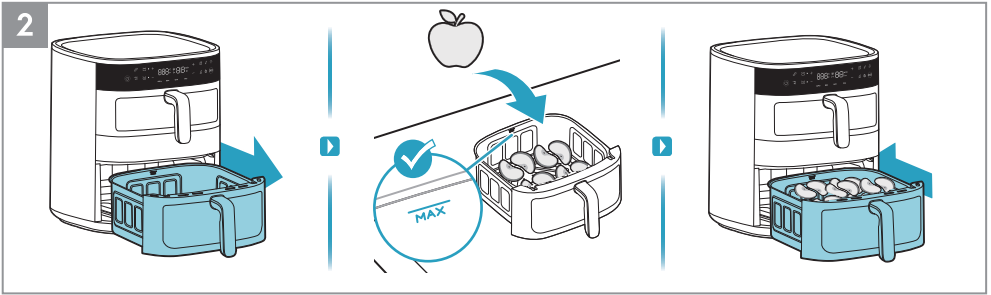

2. შემდეგ გამოიღეთ ქვედა კალათა და მოათავსეთ საკვები, მაგალითად, ვაშლის ნაჭრები.



3. დააჭირეთ ჩართვა/გამორთვის ლილავს (On/Off). აირჩიეთ ზედა კალათა. აირჩიეთ სასურველი მომზადების რეჟიმი, მაგალითად, აეროგრილის ფუნქცია. დრო და ტემპერატურა მოარგეთ თქვენს გემოვნებას ან აირჩიეთ წინასწარ დაყენებული რეცეპტებიდან ერთ-ერთი, მაგალითად, ბოსტნეული. ბოლოს დააჭირეთ დაკვრა/დაპუზების ლილავს.



4. შემდეგ აირჩიეთ ქვედა კალათა. აირჩიეთ სასურველი მომზადების რეჟიმი, მაგალითად, შრობის ფუნქცია. დრო და ტემპერატურა მორაგეთ თქვენს გემოვნებას. ბოლოს დააჭირეთ დაკვრა/დაბაუზების ლილაკს.

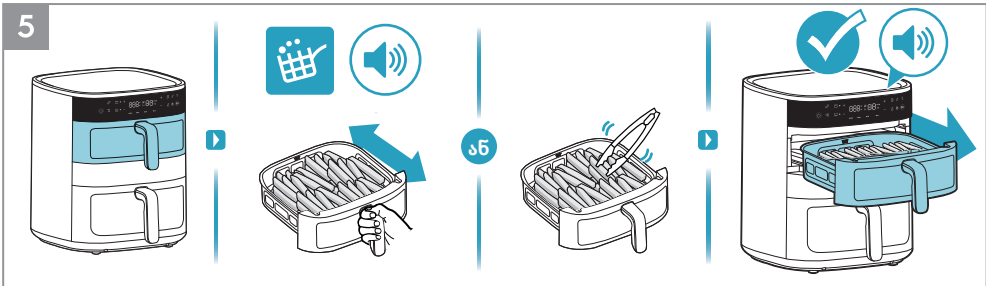

5. როდესაც მომზადების პროცესში „შერჩევის შესახებ შეხსენების“ ხატულა აინთება და ხმოვანი სიგნალი გაისმის, გამოიყენეთ სითბოგამძლე ხელსაწყოები, რათა ერთხელ გადმოაბრუნოთ საკვებ ან ფრთხილად შეაწვრიოთ კალათაში მოთავსებული ინგრედიენტები. ზედა კალათის მომზადების დროის ამონურვისას მონყობილობა გამოსცემს ხმოვან სიგნალს. ქვედა კალათის მომზადების დროის ამონურვისას მონყობილობა გამოსცემს ხმოვან სიგნალს.

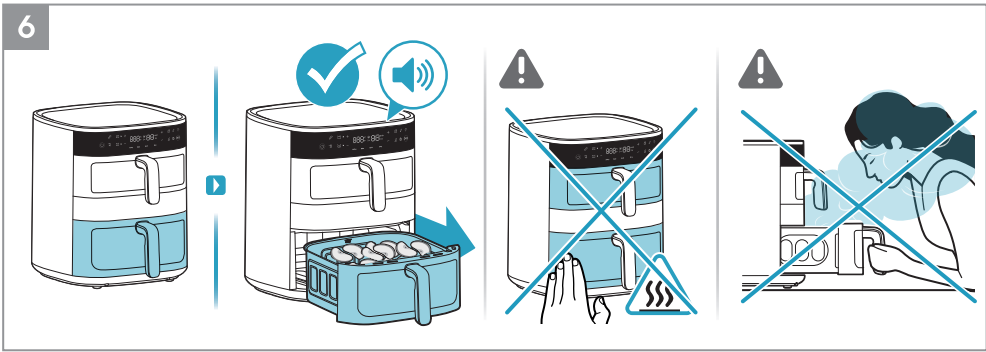

6. ქვედა კალათის მომზადების დროის ამონურვისას მონყობილობა გამოსცემს ხმოვან სიგნალს.

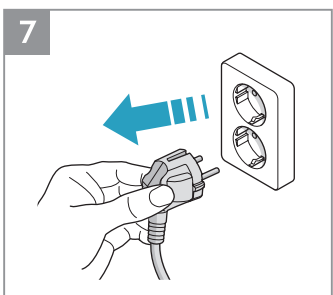

7. გამოყენების დასრულების შემდეგ მონყობილობა გამორთეთ ქსელიდან.

- EN
- BG
- CZ
- DE
- DK
- EE
- FI
- FR
- GR
- HR
- HU
- IT
- LT
- LV
- NO
- NL
- PL
- PT
- RO
- RU
- SE
- SI
- SK
- SR
- TR
- UA
- ES
- GE
- AL

EN
BG
CZ
DE
DK
EE
FI
FR
GR
HR
HU
IT
LT
LV
NO
NL
PL
PT
RO
RU
SE
SI
SK
SR
TR
UA
ES
GE
AL

ერთდროული გამოყენება - მიზმის ფუნქცია

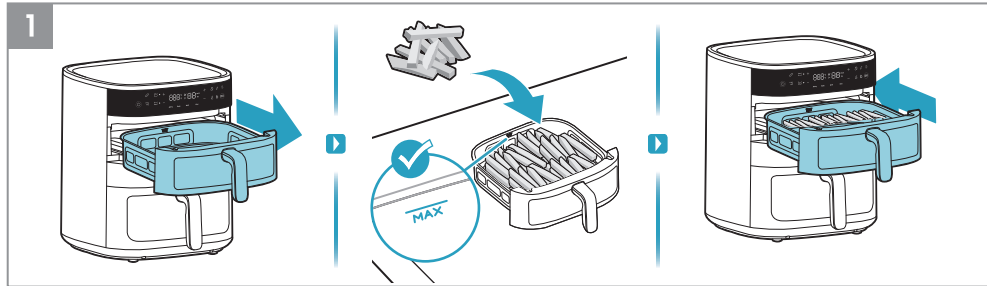

1. გამოიღეთ ზედა კალათა და მოათავსეთ საკვები, მაგალითად, კარტოფილი ფრი.

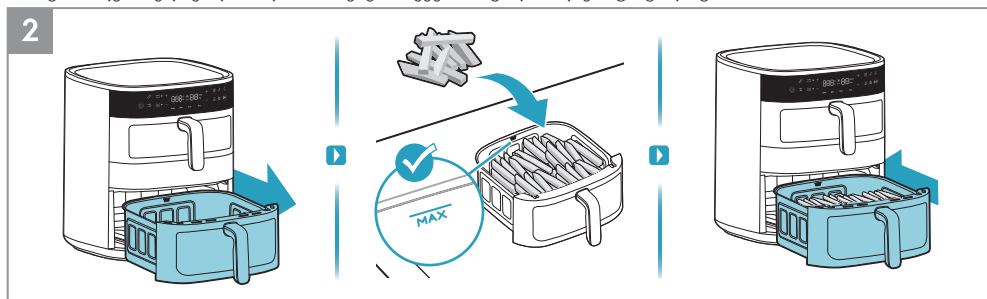

2. შემდეგ გამოიღეთ ქვედა კალათა და მოათავსეთ საკვები, მაგალითად, კარტოფილი ფრი.

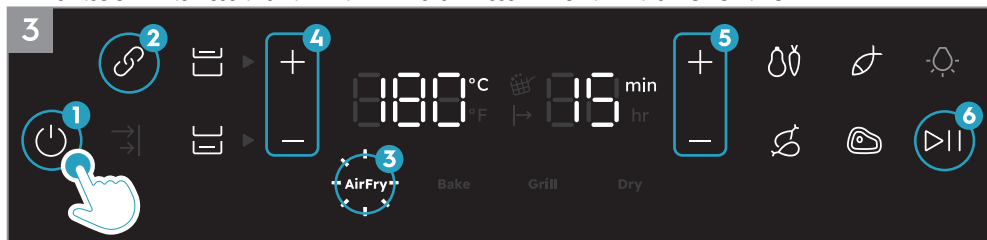

3. დააჭირეთ ჩართვა/გამორთვის ლილავს (On/Off). თავდაპირველად აირჩიეთ მიზმის ფუნქცია. აირჩიეთ სასურველი მომზადების რეჟიმი, მაგალითად, აეროგრილის ფუნქცია. დრო და ტემპერატურა მორგეთ თქვენს გემოვნებას ან აირჩიეთ წინასწარ დაყენებული რეცეპტებიდან ერთ-ერთი. ზოლოს დააჭირეთ დაკერა/დაპაუზების ლილავს.

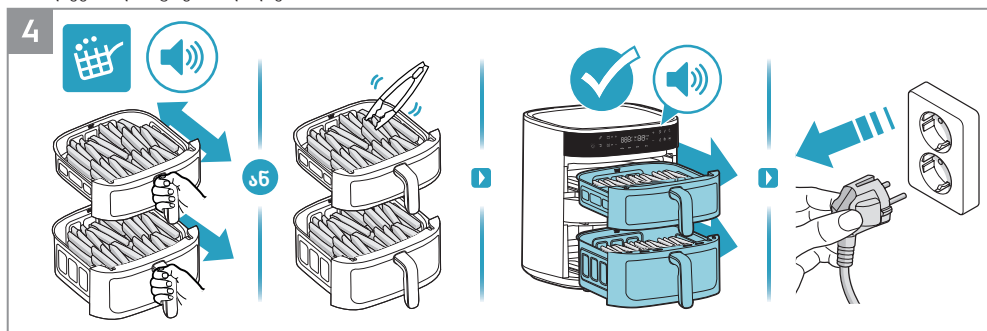

4. როდესაც მომზადების პროცესში „შერხევის შესახებ შეხსენების“ ხატულა აინთება და ხმოვანი სიგნალი გაისმის, გამოიყენეთ სითბოგამძლე ხელსაწყოები, რათა ერთხელ გადმოაბრუნოთ საკვები ან ფრთხილად შეანჯღრიოთ კალათაში მოთავსებული ინგრედიენტები. მომზადების დროის ამონურვისას მონყობილობა გამოსცემს ხმოვან სიგნალს. გამოყენების დასრულების შემდეგ მონყობილობა გამორთეთ ქსელიდან.

ერთდროული გამოყენება - დასრულების ფუნქციის სინქრონიზაცია

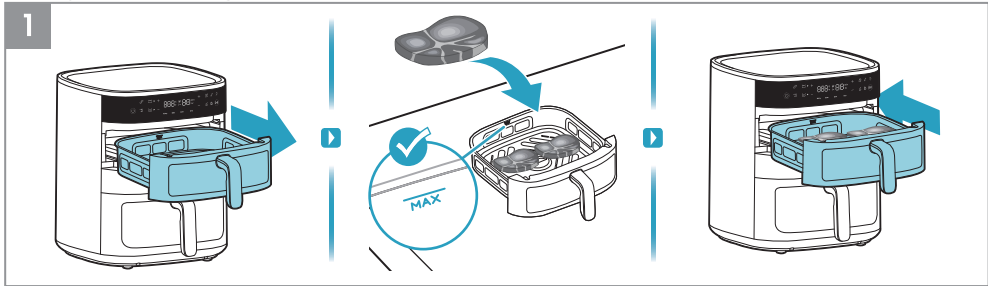

1. გამოიღეთ ზედა კალათა და მოათავსეთ საკვები, მაგალითად, სტიკი.

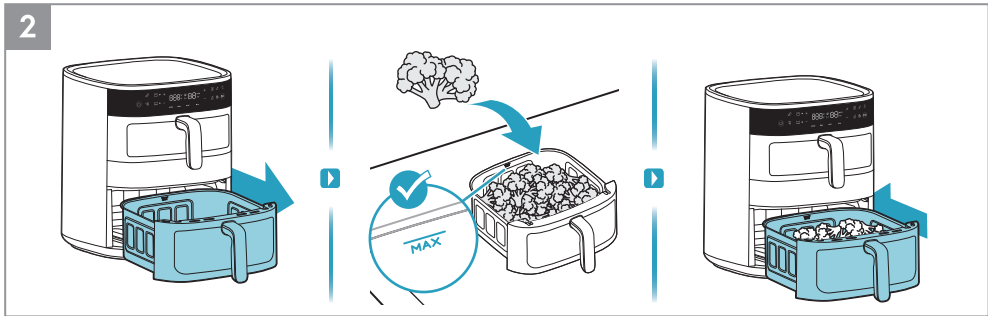

2. შემდეგ გამოიღეთ ქვედა კალათა და მოათავსეთ საკვები, მაგალითად, ბროკოლი.



3. დააჭირეთ ჩართვა/გამორთვის ლილასს (On/Off). აირჩიეთ დასრულების ფუნქციის სინქრონიზაცია. ჯერ აირჩიეთ ზედა კალათა, შემდეგ აირჩიეთ სასურველი მომზადების რეჟიმი, მაგალითად, აეროგრისის ფუნქცია. დრო და ტემპერატურა მთავრად თქვენს გემოვნებას ან აირჩიეთ ნინასნარ დაყენებული რეცეპტებიდან ერთ-ერთი, მაგალითად, სტიკი.

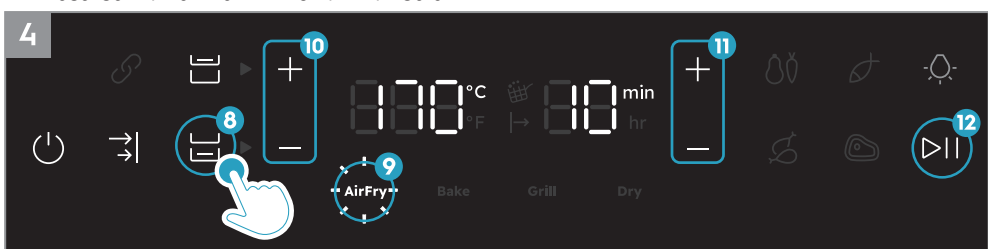

4. ხოლო შემდეგ აირჩიეთ ქვედა კალათა, აირჩიეთ სასურველი მომზადების რეჟიმი, მაგალითად, აეროგრისის ფუნქცია. დრო და ტემპერატურა მთავრად თქვენს გემოვნებას ან აირჩიეთ ნინასნარ დაყენებული რეცეპტებიდან ერთ-ერთი. ბოლოს დააჭირეთ დაკვრა/დაბაუზების ლილასს.

- EN
- BG
- CZ
- DE
- DK
- EE
- FI
- FR
- GR
- HR
- HU
- IT
- LT
- LV
- NO
- NL
- PL
- PT
- RO
- RU
- SE
- SI
- SK
- SR
- TR
- UA
- ES
- GE
- AL

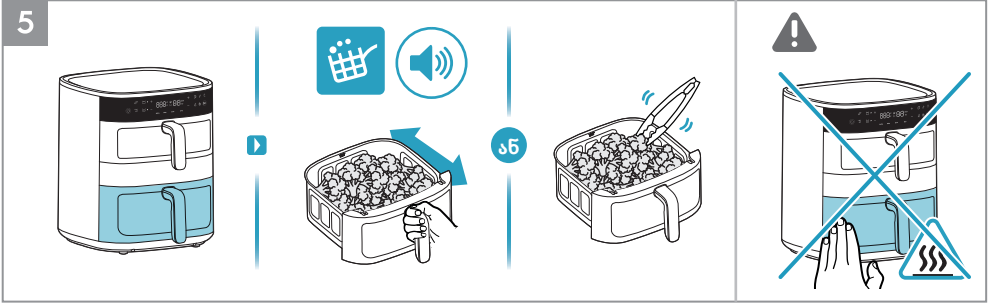

5. პირველად დაინყებს მომზადებას ქვედა კალათა, რადგან მას აქვს უფრო ხანგრძლივი დროის პარამეტრი. როდესაც მომზადების პროცესში „შერხვევის შესახებ შეხსენების“ ხატულა აინთება და ხმოვანი სიგნალი გაისმის, გამოიყენეთ სითბოგამძლე ხელსაწყოები, რათა ერთხელ გადმოაბრუნოთ საკვები ან ფრთხილად შეაწვრიოთ კალათაში მოთავსებული ინგრედიენტები.

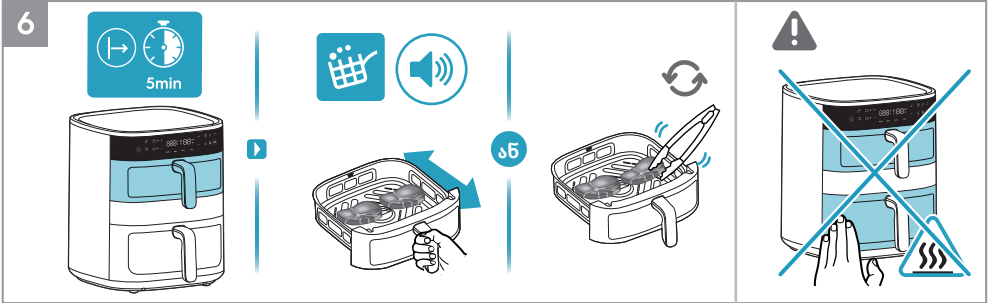

6. შემდეგ დაინყებს მომზადებას ზედა კალათა, რომელსაც ნაკლები დრო აქვს დაყენებული. როდესაც მომზადების პროცესში „შერხვევის შესახებ შეხსენების“ ხატულა აინთება და ხმოვანი სიგნალი გაისმის, გამოიყენეთ სითბოგამძლე ხელსაწყოები, რათა ერთხელ გადმოაბრუნოთ საკვები ან ფრთხილად შეაწვრიოთ კალათაში მოთავსებული ინგრედიენტები.

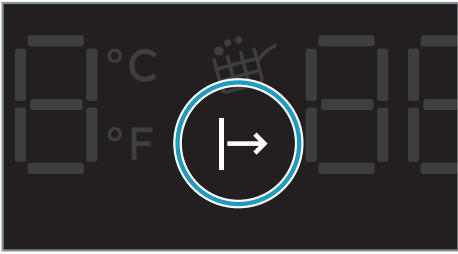

“მომზადების რეჟიმის მოლოდინი” ინდიკატორი
როდესაც “დასრულების ფუნქციის სინქრონიზაცია” აქტიურია, მოკლე დროის მქონე კალათა დაელოდება მომზადების დაწყებას, სანამ ხანგრძლივი დროის მქონე კალათა გარკვეული დროით იმუშავებს. ეს უზრუნველყოფს, რომ მომზადება ორივე კალათამ ერთსა და იმავე დროს დაასრულოს. ამ პერიოდში ანთებული იქნება “მომზადების რეჟიმის მოლოდინი” ინდიკატორი, სანამ მომზადება არ დაიწყება.



7. მომზადების დროის ამოწურვისას მოწყობილობა გამოსცემს ხმოვან სიგნალს. გამოყენების დასრულების შემდეგ მოწყობილობა გამორთეთ ქსელიდან.

გაწმენდა

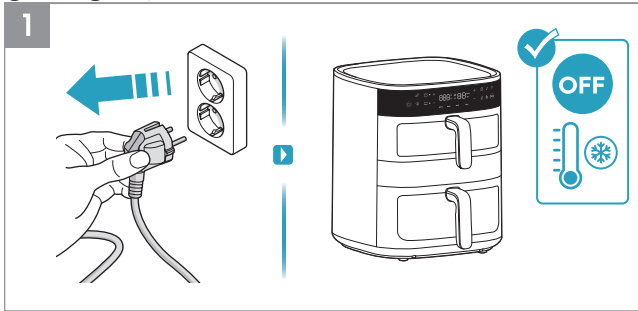

1. განმენდამდე ყოველთვის გამორთეთ მონყობილობა ქსელიდან და დაელოდეთ მის სრულ გაცივებას.
2. მონყობილობის გარე ზედაპირი განმინდეთ რბილი ნაჭრით.

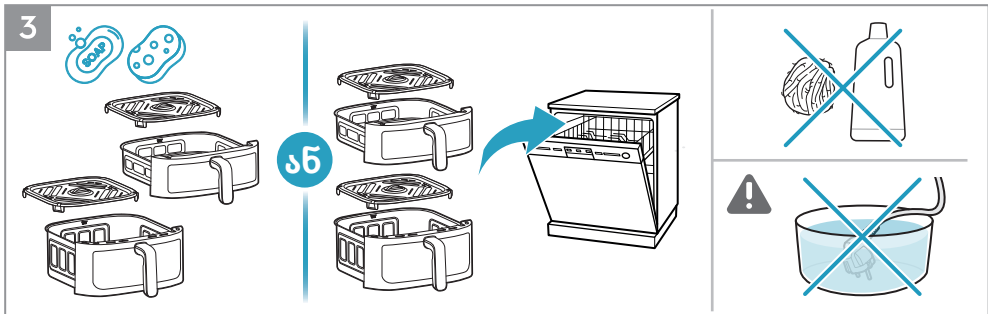
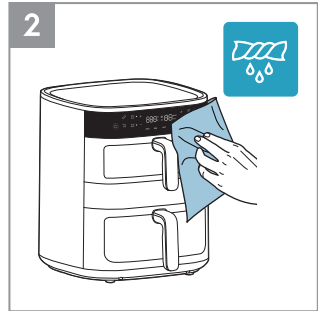

3. განმინდეთ ტაფა და გრილი თბილი წყლითა და ჭურჭლის სარეცხი სითხით, ან მოათავსეთ ისინი ჭურჭლის სარეცხ მანქანაში.

⚠შენიშვნა: არ გამოიყენოთ აბრაზიული საწმენდი საშუალებები ან ლითონის ხელსაწყოები, რათა არ დაზიანდეს არანებოვანი საფარი.

სიფრთხილე: მოწყობილობა, მისი კაბელი ან შტეფსელი არასოდეს ჩაყოთ წყალში ან სხვა სითხეში.

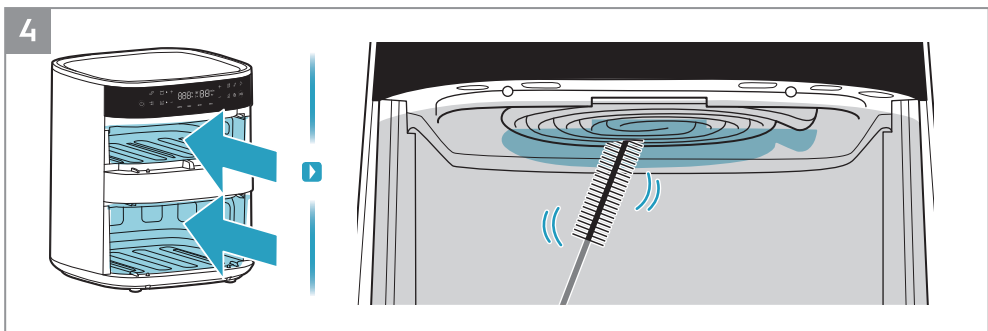

















































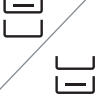





















4. გათბობის ელემენტი განმინდეთ სანმენდი ჯაგრისით.

შენიშვნა: სანამ გათბობის ელემენტს განმენდთ, დარწმუნდით, რომ მონყობილობა სრულად გაცივებულია.

EN
BG
CZ
DE
DK
EE
FI
FR
GR
HR
HU
IT
LT
LV
NO
NL
PL
PT
RO
RU
SE
SI
SK
SR
TR
UA
ES
GE
AL

მომზადების სახელმძღვანელო

							
AirFry	7mm/10mm 	4 ჯ 	400გ	180°C	18 წთ		
		7 ჯ 	400გ	180°C	18 წთ		
AirFry		4 ჯ 	400გ	170°C	8 წთ		
		7 ჯ 	400გ	170°C	10 წთ		
AirFry		4 ჯ 	400გ/2ცალი	140°C	15 წთ		
		7 ჯ 	400გ/2ცალი	140°C	15 წთ		
AirFry		4 ჯ 	1000გ/8ცალი	180°C	28 წთ		
		7 ჯ 	1000გ/8ცალი	180°C	28 წთ		
AirFry		4 ჯ 	400გ/2ცალი	200°C	10 წთ		
		7 ჯ 	400გ/2ცალი	200°C	10 წთ		
AirFry		4 ჯ 	220გ/6ინჩი	160°C	12 წთ		
		7 ჯ 	220გ/6ინჩი	160°C	14 წთ		

							
AirFry		 7 	1200g	180°C	55 წთ		
AirFry		 7 	400g/9 ცალი	160°C	20 წთ		
Grill		 4 	180g/4 ცალი	180°C	8 წთ		
Grill		 7 	180g/4 ცალი	180°C	9 წთ		
Dry		 4 	180g	80°C	3სთ		
Dry		 7 	180g	80°C	3სთ		
Dry		 4 	200g	80°C	3სთ		
Dry		 7 	200g	80°C	3სთ		

- EN
- BG
- CZ
- DE
- DK
- EE
- FI
- FR
- GR
- HR
- HU
- IT
- LT
- LV
- NO
- NL
- PL
- PT
- RO
- RU
- SE
- SI
- SK
- SR
- TR
- UA
- ES
- GE**
- AL

EN
BG
CZ
DE
DK
EE
FI
FR
GR
HR
HU
IT
LT
LV
NO
NL
PL
PT
RO
RU
SE
SI
SK
SR
TR
UA
ES
GE
AL

როგორ უნდა მოიქცეთ იმ შემთხვევაში, თუ...

პრობლემა	შეამოწმეთ, თუ...
მონყობილობის ჩართვა/ გამოყენება ვერ ხერხდება.	<ul style="list-style-type: none"> • მონყობილობა სწორად არის შეერთებული ელექტროსადენთან. • კალათები სწორ პოზიციაშია. დარწმუნდით, რომ ისინი სრულად არის შეწეული მონყობილობაში, რათა მოხდეს კვების მიწოდება. • მომზადების დრო დაყენებულია.
კალათის შეწევა მონყობილობაში ვერ ხერხდება.	<ul style="list-style-type: none"> • კალათა გადავსებულია და აღემატება მაქსიმალურ ტევადობას. • კალათა სწორად არის მოთავსებული. კალათა თავის ადგილას დანაკაპუნებით უნდა ჩაჯდეს. • კალათის ქვემოთ რაიმე საგანია, რომელიც ხელს უშლის მის სწორად დახურვას.
მონყობილობიდან გამოდის თეთრი კვამლი.	<ul style="list-style-type: none"> • საკვები ზედმეტად ცხიმოვანია. • კალათა, გრილი და გათბობის ელემენტი სუფთაა.
ეკრანზე ჩანს E1	• ზედა კალათის წრედი განყვეტილია.
ეკრანზე ჩანს E2	• ზედა კალათის მოკლე ჩართვა.
ეკრანზე ჩანს E3	• ქვედა კალათის წრედი განყვეტილია.
ეკრანზე ჩანს E4	• ქვედა კალათის მოკლე ჩართვა.
ეკრანზე ჩანს E5	• მართვის პლატის (Control PCBA) კომუნიკაციის შეცდომა.
ეკრანზე ჩანს E6	• კვების პლატის (Power PCBA) კომუნიკაციის შეცდომა.

* თუ ეკრანზე გამოჩნდება შეცდომის კოდები, მონყობილობა უნდა შეკეთდეს სერვისცენტრში.

ტექნიკური მონაცემები

პროდუქტი	აეროგრილი
მოდელი	EAFD11B
ძაბვა (V~)	220 V - 240 V
სიმძლავრე (W)	2700 W
სიხშირე (Hz)	50 ~ 60 Hz
ტევადობა	4 ლ + 7 ლ



Udhëzues

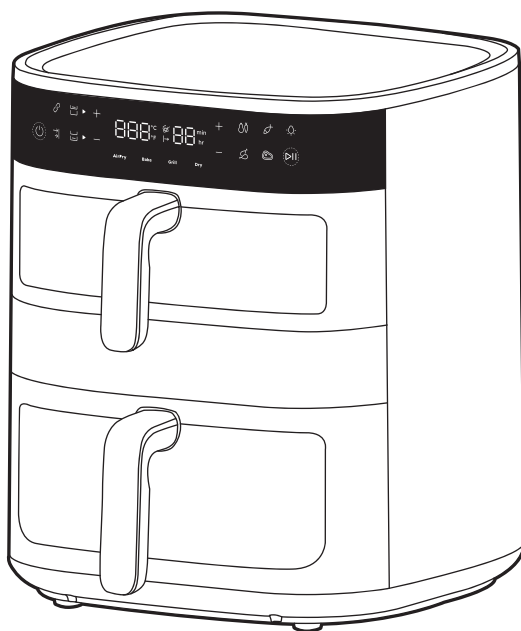

Fritezë me ajër Dual 800

Pasqyrë e përgjithshme

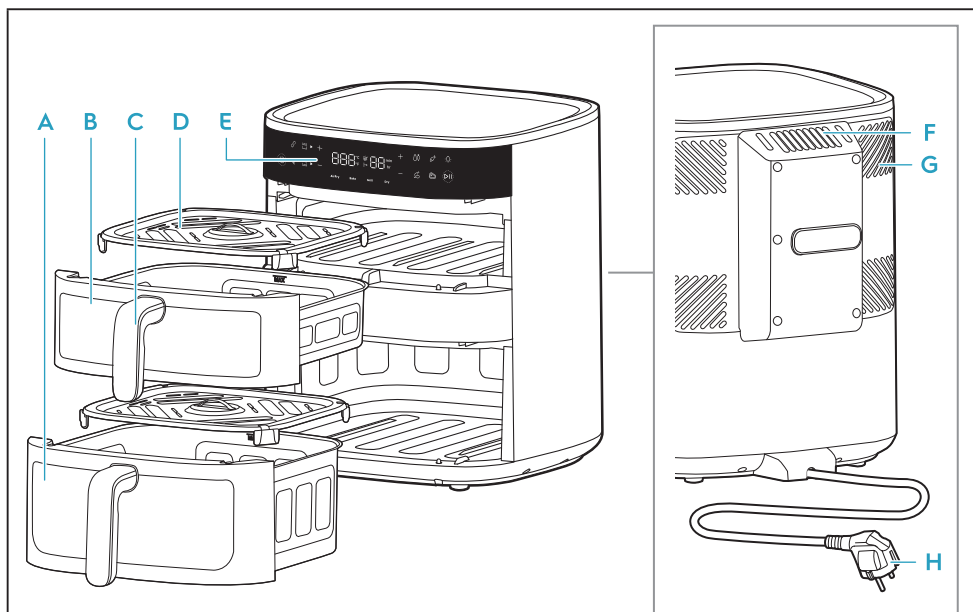

- A** Shporta e poshtme (7L) **C** Doreza e shportës **E** Paneli i kontrollit **G** Sistemi ftohës
B Shporta e sipërme (4L) **D** Skara **F** Porta dalje e ajrit **H** Kordoni kryesor

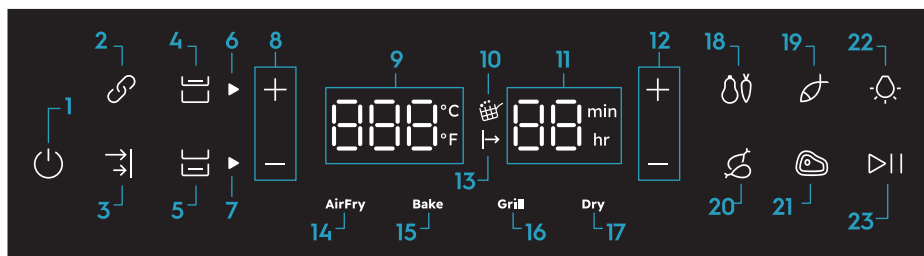

- Ndezje/Fikje
- Funksioni lidhës
- Funksioni i përfundimit të sinkronizimit
- Kontrulli i shportës së sipërme
- Kontrulli i shportës së poshtme
- Treguesi i shportës së sipërme
- Treguesi i shportës së poshtme
- Kontrulli i temperaturës
- Treguesi i temperaturës (40-200°C)
- Kujtesa e tundjes
- Treguesi i kohës (Skuaje me ajër: 1-99 minuta, tharje: 1-5 orë)
- Komanda e kohës
- Në pritje të gatimit
- Funksioni i skuajes me ajër
- Funksioni i pjekjes
- Funksioni i skarës
- Funksioni i tharjes
- Perime
- Peshk
- Pulë
- Biftek
- Komanda e dritës
- Fillo/Ndalo

Para përdorimit të parë

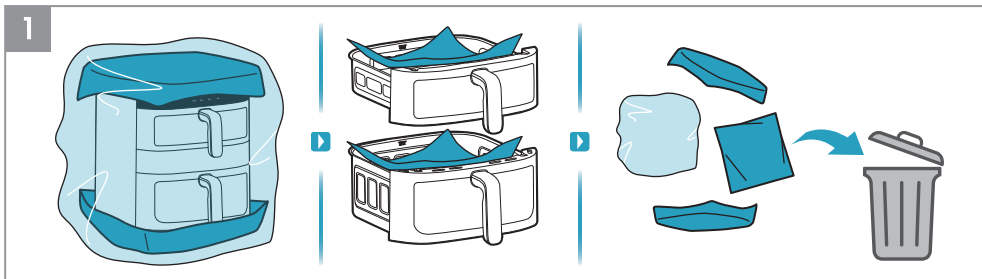

1. Hiqni paketimin dhe materialin mbrojtës.

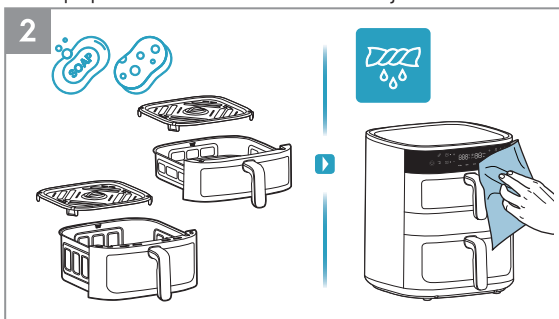

2. Lajeni tiganin dhe skarën me ujë të ngrohtë dhe solucion enësh. Fshini pajisjen brenda dhe jashtë me një copë të butë.

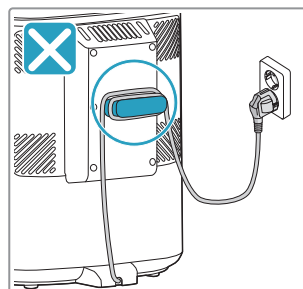
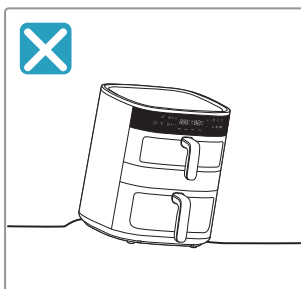
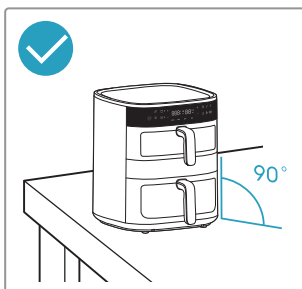
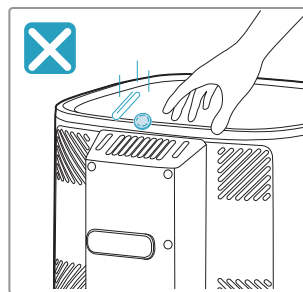
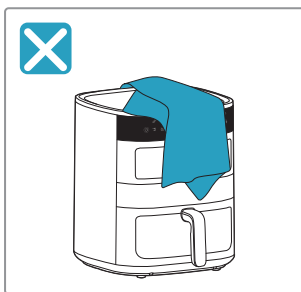

3. Është normale që një pajisje e re të lëshojë aroma herën e parë që përdoret. Lëreni fritezën me ajër të punojë bosh me 200°C për 20 minuta para përdorimit të parë për ta shmangur këtë.

! Masat paraprake





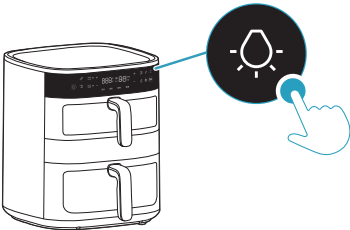
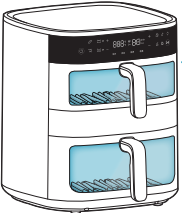

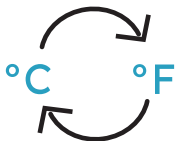









EN
BG
CZ
DE
DK
EE
FI
FR
GR
HR
HU
IT
LT
LV
NO
NL
PL
PT
RO
RU
SE
SI
SK
SR
TR
UA
ES
GE
AL







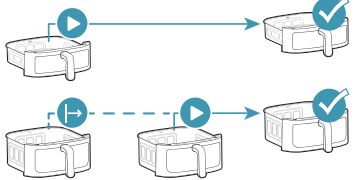







Komanda e dritave dhe e konvertimit të vlerave të temperaturës

 <p>Komanda e dritave</p>		 <p>30 sekonda</p>
<p>°C/°F</p> <p>Komanda e konvertimit të vlerave të temperaturës</p>	 <p>30 sekonda</p>	

Përzgjedhja e shportës

	 <p>4L</p>	 <p>7L</p>	
 <p>Shporta e sipërme</p>			
 <p>Shporta e poshtme</p>			
 <p>Funksioni lidhës</p>			
 <p>Funksioni i përfundimit të sinkronizimit</p>			

Funksionet e paracaktuara

 Air Fry					
Air Fry	180°C	15minuta	60-200°C	1-99minuta	
	170°C	10minuta	60-200°C	1-99minuta	
	140°C	15minuta	60-200°C	1-99minuta	
	180°C	30minuta	60-200°C	1-99minuta	
	200°C	10minuta	60-200°C	1-99minuta	
Bake	170°C	15minuta	60-200°C	1-99minuta	
Grill	200°C	5minuta	60-200°C	1-99minuta	
Dry	80°C	5 orë	40-80°C	1-5 orë	

Para gatimit

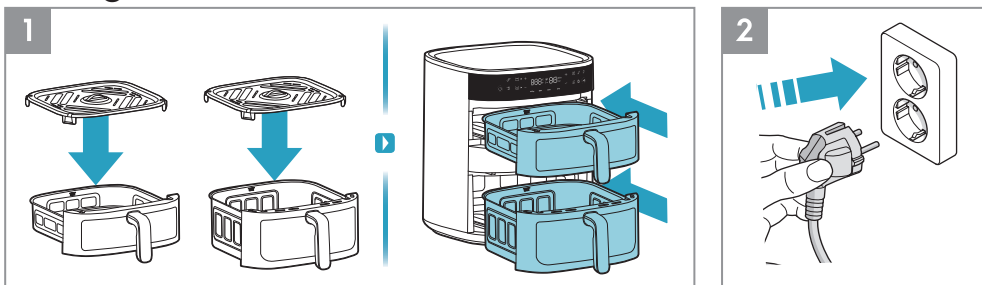

1. Para çdo gatimi, lutemi ta vendosni skarën brenda shportës (mbështetësja e skarës prej silikoni me durueshmëri ndaj nxehtësisë nuk ka nevojë të hiqet), dhe ta shtyni shportën plotësisht brenda pajisjes.
2. Futeni spinën e pajisjes në prizë.

EN
BG
CZ
DE
DK
EE
FI
FR
GR
HR
HU
IT
LT
LV
NO
NL
PL
PT
RO
RU
SE
SI
SK
SR
TR
UA
ES
GE
AL

Si ta përdorni - shporta teke

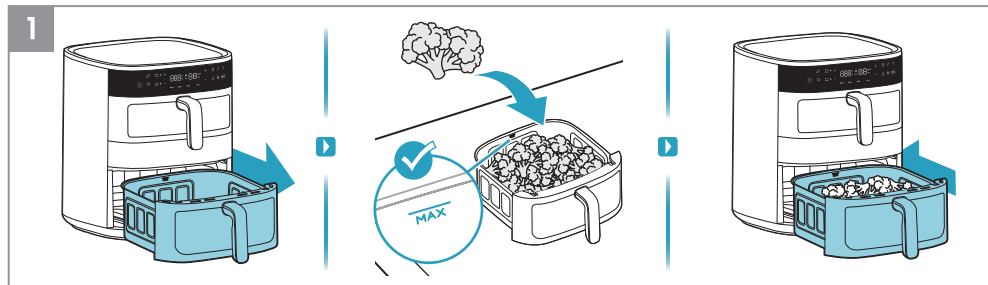

1. Nxirrni njërën nga shportat dhe vendoseni mbi një sipërfaqe të qëndrueshme, vendoseni ushqimin në shportë duke pasur parasysh udhëzimin mbi kapacitetin maksimal. Më pas, shtyjeni shportën me ushqim plotësisht brenda pajisjes.

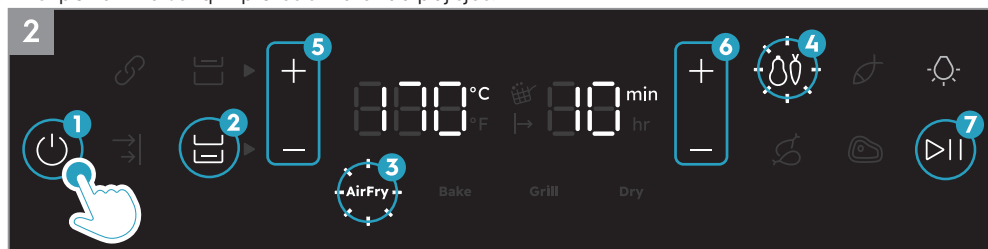

2. Shtypni butonin Ndezje/Fikje. Fillimisht, zgjidhni shportën me ushqim. Më pas, zgjidhni metodën e dëshiruar të gatimit, për shembull, funksioni i skuqjes me ajër. Gradoni kohën dhe temperaturën sipas dëshirës ose zgjidhni një nga recetat e paracaktuara, për shembull, perime. Në fund, shtypni butonin Fillo/Ndalo.

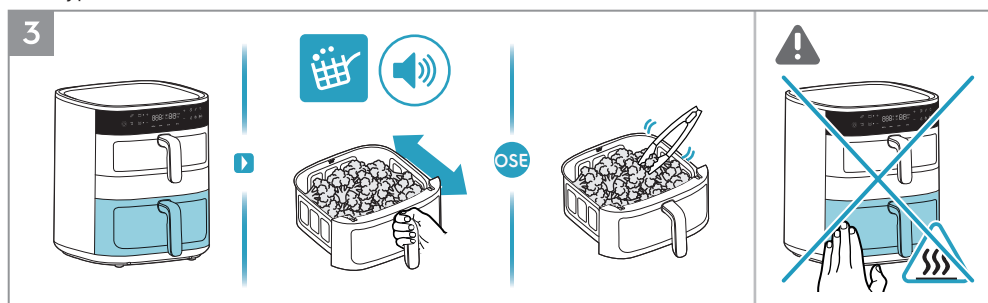

3. Kur ikona “Kujtesa e tundjes” ndriçon dhe tingëllon gjatë procesit të gatimit, përdorni mjete rezistente ndaj nxehtësisë për të kthyer ushqimin ose tundeni me kujdes ushqimin në shportë.

⚠ **KUJDES:** Mos e tundni fort shportën sepse mund të spërkateni me ushqim ose mund të digjeni.

⚠ **KUJDES:** Kujdes nga sipërfaqet e nxehta kur pajisja është në përdorim.

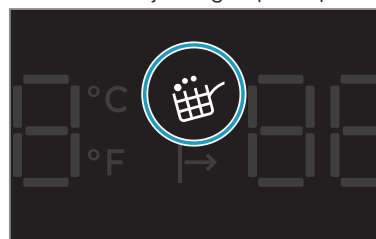

Kujtesa e tundjes

“Kujtesa e tundjes” aktivizohet gjatë funksionit të skuqjes me ajër dhe recetave të paracaktuara, si perimet, peshku, kofshët e pulës dhe bifteku.

Kur vjen koha për të tundur ose kthyer ushqimin, ikona “Kujtesa e tundjes” do të ndriçojë dhe do të pulsojë një minutë, ndërkohë që një tingull do të dëgjohet tri herë.

“Kujtesa e tundjes” nuk është e detyrueshme, ndaj procesi i gatimit do të vazhdojë si zakonisht, paçka se ushqimi nuk kthehet ose tundet



4. Në fund të procesit të gatimit, pajisja do të lëshojë një sinjal zanor. Hiqeni me kujdes shportën dhe vendoseni mbi një sipërfaqe rezistente ndaj të nxehtit. Hiqeni nga priza pajisjes pas përdorimit.

⚠ **KUJDES:** Avulli i nxehtë mund të dalë nga shporta kur procesi ndalet në mes ose në fund të gatimit. Sigurohuni që fytyra, krahët dhe duart të jenë larg avullit kur hapni pajisjen.

Si ta përdorni - shporta e sipërme dhe e poshtme

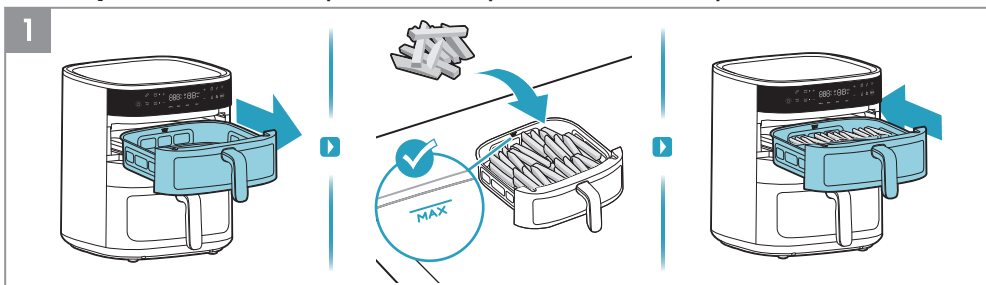

1. Së pari, nxirreni shportën e sipërme, vendosni ushqimin brenda shportës, për shembull, patate të skuqura.

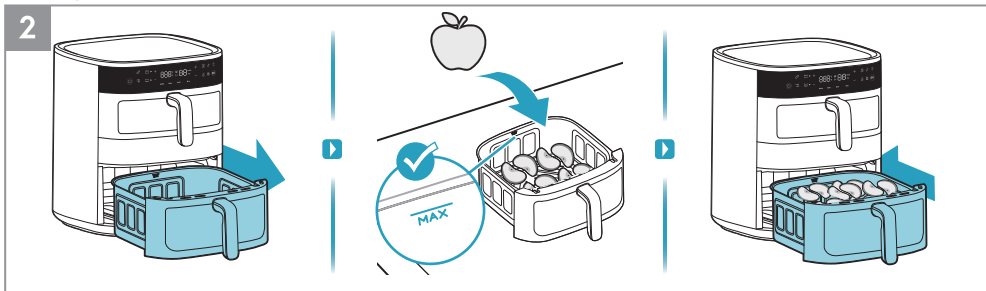

2. Së dyti, nxirreni shportën e poshtme, vendosni ushqimin brenda shportës, për shembull, feta molle.



3. Shtypni butonin Ndezje/Fikje. Në fillim zgjidhni shportën e sipërme. Më pas, zgjidhni metodën e dëshiruar të gatimit, për shembull, funksioni i skuqjes me ajër. Gradoni kohën dhe temperaturën sipas dëshirës ose zgjidhni një nga recetat e paracaktuara, për shembull, perime. Në fund, shtypni butonin Fillo/Ndalo.



4. Së dyti, zgjidhni shportën e poshtme. Më pas, zgjidhni metodën e dëshiruar të gatimit, për shembull, funksioni i tharjes. Gradoheni kohën dhe temperaturën sipas dëshirës. Në fund, shtypni butonin Fillo/Ndalo.

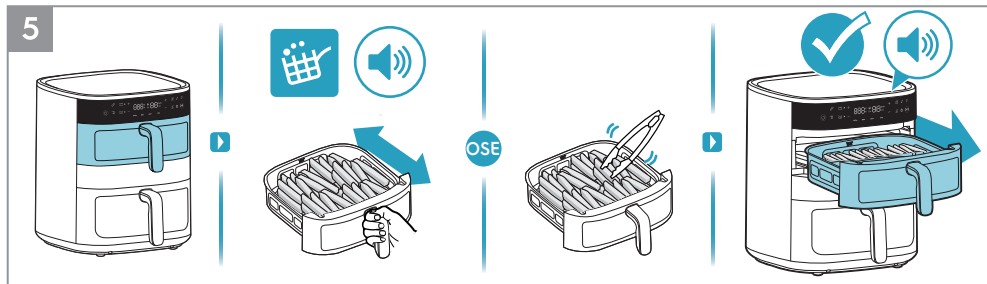

5. Kur ikona “Kujtesa e tundjes” ndriçon dhe tingëllon gjatë procesit të gatimit, përdorni mjete rezistente ndaj nxehtësisë për të kthyer ushqimin ose tundeni me kujdes ushqimin në shportë. Në fund të gatimit të ushqimit në shportën e sipërme, pajisja do të lëshojë një sinjal zanor.

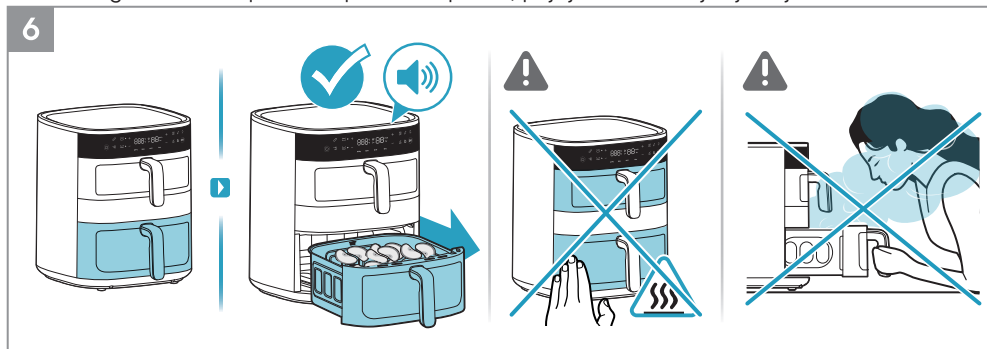

6. Në fund të gatimit të ushqimit në shportën e poshtme, pajisja do të lëshojë një sinjal zanor.

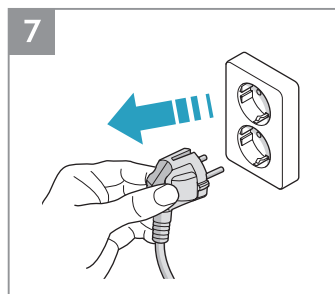

7. Hiqeni nga prizat pajisjen pas përdorimit.

Si ta përdorni - funksioni lidhës

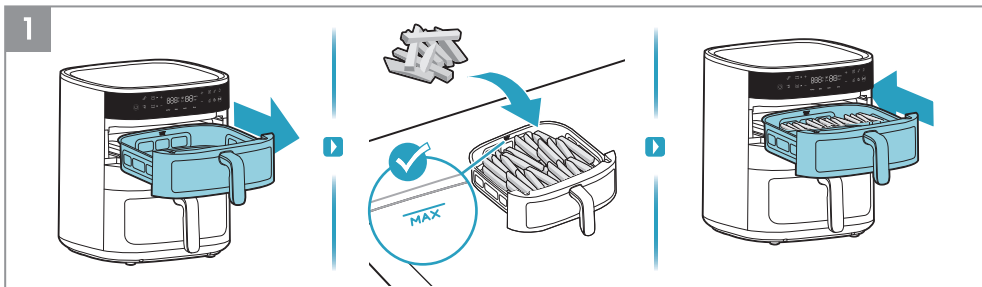

1. Së pari, nxirreni shportën e sipërme, vendosni ushqimin brenda shportës, për shembull, patate të skuqura.

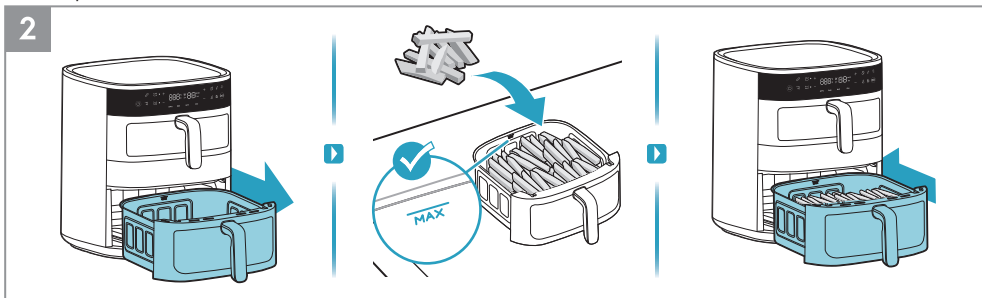

2. Së dyti, nxirreni shportën e poshtme, vendoseni ushqimin brenda shportës, për shembull, patate të skuqura.



3. Shtypni butonin Ndezje/Fikje. Fillimisht, zgjidhni funksionin lidhës. Më pas, zgjidhni metodën e dëshiruar të gatimit, për shembull, funksioni i skuqjes me ajër. Gradoni kohën dhe temperaturën sipas dëshirës ose zgjidhni një nga recetat e paracaktuara. Në fund, shtypni butonin Fillu/Ndalo.

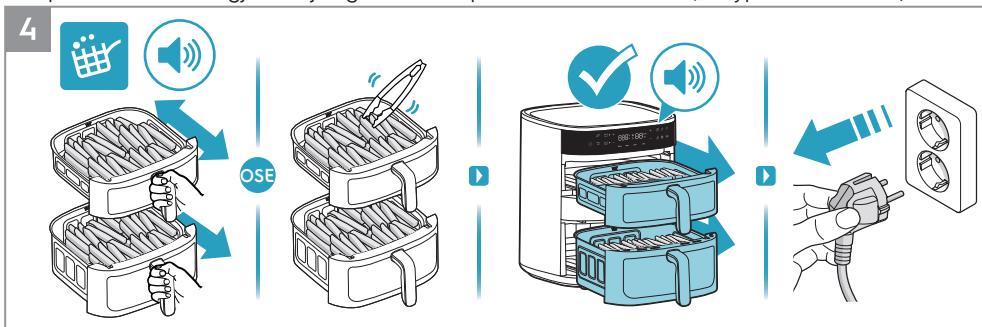

4. Kur ikona "Kujtesa e tundes" ndriçon dhe tingëllon gjatë procesit të gatimit, përdorni mjete rezistente ndaj nxehtësisë për të kthyer ushqimin ose tundeni me kujdes ushqimin në shportë. Në fund të procesit të gatimit, pajisja do të lëshojë një sinjal zanor. Hiqeni nga priza pajisjen pas përdorimit.

EN
BG
CZ
DE
DK
EE
FI
FR
GR
HR
HU
IT
LT
LV
NO
NL
PL
PT
RO
RU
SE
SI
SK
SR
TR
UA
ES
GE

AL

EN
BG
CZ
DE
DK
EE
FI
FR
GR
HR
HU
IT
LT
LV
NO
NL
PL
PT
RO
RU
SE
SI
SK
SR
TR
UA
ES
GE
AL

Si ta përdorni - funksioni i përfundimit të sinkronizimit

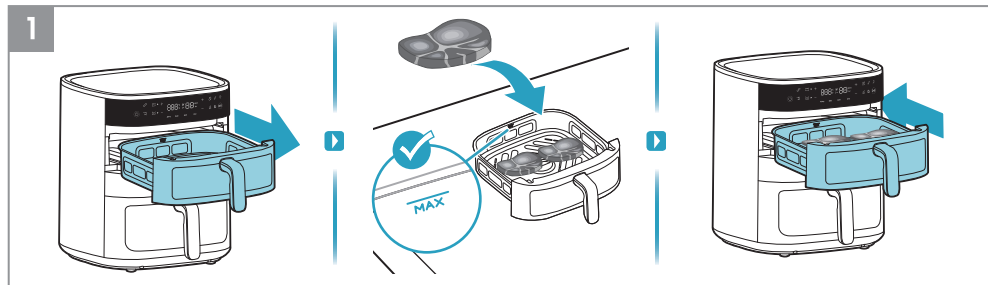

1. Së pari, nxirreni shportën e sipërme dhe vendoseni ushqimin brenda shportës, për shembull, biftek.

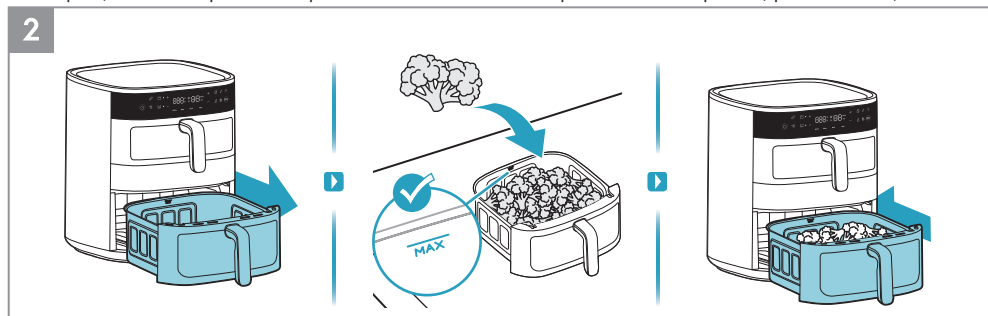

2. Së dyti, nxirreni shportën e poshtme dhe vendoseni ushqimin brenda shportës, për shembull, brokoli.



3. Shtypni butonin Ndezje/Fikje. Zgjidhni funksionin e përfundimit të sinkronizimit Fillimisht, zgjidhni shportën e sipërme, me pas zgjidhni metodën e dëshiruar të gatimit, për shembull, funksionin e skuqjes me ajër. Gradoni kohën dhe temperaturën sipas dëshirës ose zgjidhni një nga recetat e paracaktuara, për shembull, biftek.



4. Më pas, zgjidhni shportën e poshtme, zgjidhni metodën e dëshiruar të gatimit, për shembull, funksionin e skuqjes me ajër. Gradoni kohën dhe temperaturën sipas dëshirës ose zgjidhni një nga recetat e paracaktuara. Në fund, shtypni butonin Fillo/Ndalo.

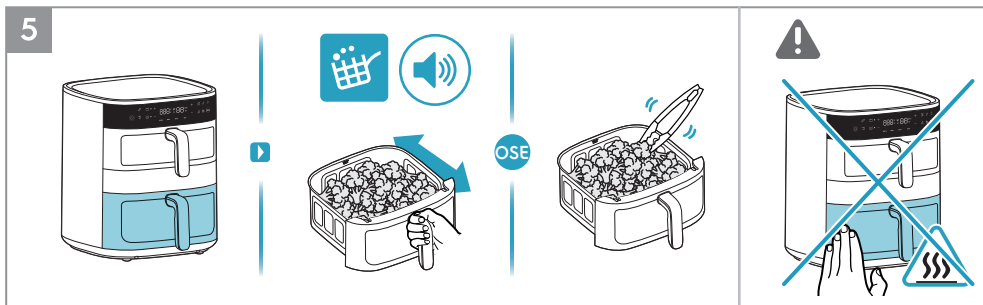

5. Së pari, shporta e poshtme me kohën më të gjatë të gatimit do të ketë përparësi për gatim. Kur ikona "Kujtesa e tundjes" ndriçon dhe tingëllon gjatë procesit të gatimit, përdorni mjete rezistente ndaj nxehtësisë për të kthyer ushqimin ose tundeni me kujdes ushqimin në shportë.

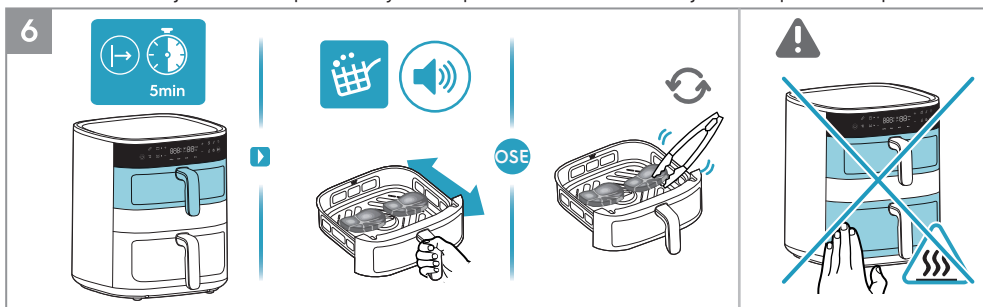

6. Së dyti, shporta e sipërme me kohë më të shkurtër të gatimit do të fillojë të gatujë. Kur ikona "Kujtesa e tundjes" ndriçon dhe tingëllon gjatë procesit të gatimit, përdorni mjete rezistente ndaj nxehtësisë për të kthyer ushqimin ose tundeni me kujdes ushqimin në shportë.

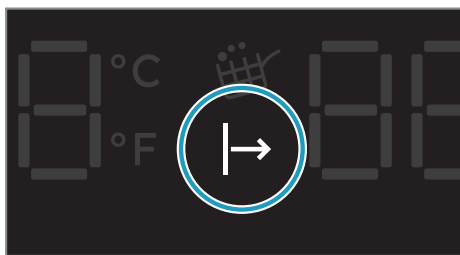

Në pritje të treguesit të gatimit

Kur aktivizohet "Funkzioni i përfundimit të sinkronizimit", shporta me kohën më të shkurtër të gatimit do të jetë në pritje të gatimit deri sa të mbarojë së gatuari ushqimi në shportën me kohën më të gjatë, në mënyrë që të dyja shportat të përfundojnë së gatuari njëkohësisht. Gjatë kësaj kohe, ikona "në pritje të treguesit të gatimit" do të ndriçojë deri sa gatimi të nisë.

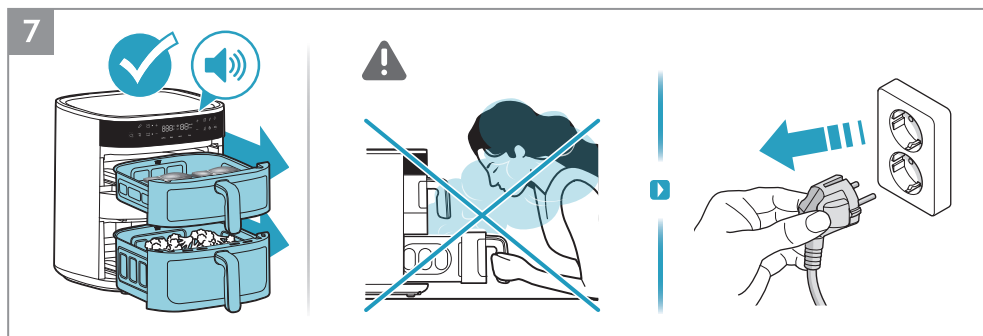

7. Në fund të procesit të gatimit, pajisja do të lëshojë një sinjal zanor. Hiqeni nga priza pajisjen pas përdorimit

Pastrimi

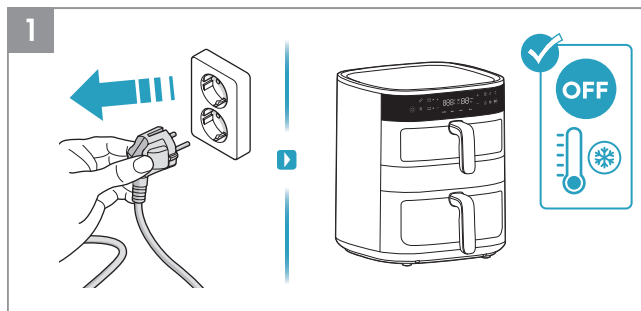

1. Hiqeni gjithmonë nga priza pajisjen dhe prisni sa të ftohet përpara se ta pastroni.
2. Fshije pajisjen nga jashtë me një copë të butë.

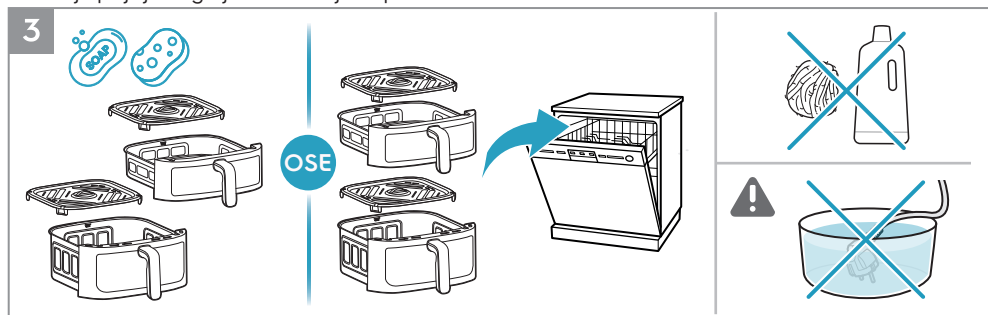

3. Lajeni tiganin dhe skarën me ujë të ngrohtë dhe solucion enësh, ose futini në lavastovilje.

▲SHËNIM: Shmangni përdorimin e substancave gërryese ose mjeteve metalike në mënyrë që të mbrohi sipërfaqen jo të ngjitshme.



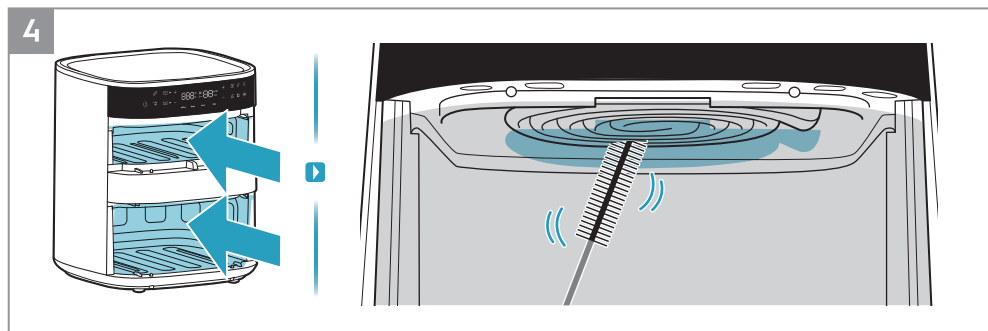









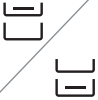

























KUJDES: Mos e zhysni kurrë produktin, kordonin ose prizën në ujë apo në ndonjë lëng tjetër.



4. Pastroheni elementin nxehtës me një furçë.













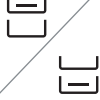













SHËNIM: Sigurohuni që pajisja të jetë ftohur plotësisht para se të pastroni elementin nxehtës.

Udhëzuesi i gatimit

							
AirFry	7mm/10mm 	 4L	400gr	180°C	18minuta		
		 7L	400gr	180°C	18minuta		
AirFry		 4L	400gr	170°C	8minuta		
		 7L	400gr	170°C	10minuta		
AirFry		 4L	400gr/2dy pjesë	140°C	15minuta		
		 7L	400gr/2dy pjesë	140°C	15minuta		
AirFry		 4L	1000gr/8dy pjesë	180°C	28minuta		
		 7L	1000gr/8dy pjesë	180°C	28minuta		
AirFry		 4L	400gr/2dy pjesë	200°C	10minuta		
		 7L	400gr/2dy pjesë	200°C	10minuta		
AirFry		 4L	220gr/15 cm	160°C	12minuta		
		 7L	220gr/15 cm	160°C	14minuta		

- EN
- BG
- CZ
- DE
- DK
- EE
- FI
- FR
- GR
- HR
- HU
- IT
- LT
- LV
- NO
- NL
- PL
- PT
- RO
- RU
- SE
- SI
- SK
- SR
- TR
- UA
- ES
- GE
- AL

EN
BG
CZ
DE
DK
EE
FI
FR
GR
HR
HU
IT
LT
LV
NO
NL
PL
PT
RO
RU
SE
SI
SK
SR
TR
UA
ES
GE
AL

							
AirFry		7L 	1200gr	180°C	55minuta		
AirFry		7L 	400g/9dy pjesë	160°C	20minuta		
Grill		4L 	180g/4dy pjesë	180°C	8minuta		
Grill		7L 	180g/4dy pjesë	180°C	9minuta		
Dry		4L 	180gr	80°C	3orë		
Dry		7L 	180gr	80°C	3orë		
Dry		4L 	200gr	80°C	3orë		
Dry		7L 	200g	80°C	3orë		

Çfarë të bëni nëse...

Problemi	Kontrolloni nëse...
Nuk mund të ndizni apo përdorni pajisjen.	<ul style="list-style-type: none"> • Pajisja është e lidhur si duhet me rrymën. • Shportat janë në pozicionin e duhur. Sigurohuni që të jenë futur plotësisht brenda pajisjes para se ta fusni në prizë. • Koha e gatimit është vendosur.
Nuk mund të fusni shportën brenda pajisjes.	<ul style="list-style-type: none"> • Shporta është mbushur mbi kapacitetin maksimal. • Shporta është vendosur saktë. Duhet të kërcasë kur e vendosni brenda pajisjes. • Ka një objekt poshtë shportës që nuk e lejon të mbyllet si duhet.
Tym i bardhë del nga pajisja.	<ul style="list-style-type: none"> • Ushqimi që përgatit ka shumë yndyrë. • Shporta, skara dhe elementi nxehtë janë të pastra.
Në ekran shfaqet E1	<ul style="list-style-type: none"> • Qark i hapur në shportën e sipërme.
Në ekran shfaqet E2	<ul style="list-style-type: none"> • Qark i shkurtër në shportën e sipërme.
Në ekran shfaqet E3	<ul style="list-style-type: none"> • Qark i hapur në shportën e poshtme.
Në ekran shfaqet E4	<ul style="list-style-type: none"> • Qark i shkurtër në shportën e poshtme.
Në ekran shfaqet E5	<ul style="list-style-type: none"> • Dështim në lidhjen me kontrollin PCBA.
Në ekran shfaqet E6	<ul style="list-style-type: none"> • Dështim në lidhjen me rrymën PCBA.

* Në rast se në ekran shfaqen kode të gabimit, pajisja duhet riparuar nga një servis i autorizuar.

Të dhëna teknike

Produkti	Fritezë me ajër
Model	EAFD11B
Voltage (V~)	220 V - 240 V
Fuqia (W)	2700 W
Frekuenca (Hz)	50 ~ 60 Hz
Kapaciteti	4 L + 7 L

